

ASSESSING THE INFLUENCE OF CULTURAL BACKGROUNDS ON LIGHTING
PREFERENCES AND THEIR IMPACT ON VISUAL PERFORMANCE

by

Omar Alkharraz

B.S., University of Colorado Boulder, 2022

A thesis submitted to the
Faculty of the Graduate School of the
University of Colorado in partial fulfillment
of the requirement for the degree of
Master of Engineering & Applied Science
Department of Civil, Environmental and Architectural Engineering (CEAE)
2025

Committee Members:

Jennifer Scheib

Robert G. Davis

Sandra Vásconez

ABSTRACT

Alkharraz, Omar (MSng, Civil, Environmental and Architectural Engineering (CEAE))

Assessing the Influence of Cultural Backgrounds on Lighting Preferences and Their Impact on Visual Performance

Thesis directed by Associate Professor Jennifer Scheib

The aim of this study was to determine whether different cultural backgrounds influence visual performance and lighting preferences under various lighting scenes that vary in illuminance and correlated color temperature. Previous research identified cross-cultural differences in mood and preferences; however, no clear link has been established between these factors and visual performance. This study aims to address this gap by conducting an experiment in an office-like setting, where participants completed a cognitive task under six lighting conditions. A total of 27 participants from three world regions were involved. Results showed differences in performance between cultures, with sleep and culture emerging as the most significant factors. Lighting conditions had no effect on performance, suggesting that other cultural or environmental factors may play a stronger role. While preferences for lighting varied across cultures, no correlation was found between lighting preferences and visual performance. Future research should investigate additional factors that influence visual performance to ensure the needs of the diverse group of people working in offices and schools.

ACKNOWLEDGMENT

I want to express my sincere gratitude to Professor Jennifer Scheib for her unwavering mentorship and guidance throughout the development of this thesis. Her insightful support was instrumental at every stage of the project. I am also deeply thankful to Professor Wendy Martin for her valuable assistance with the data analysis, which greatly enriched the study. A heartfelt thank you goes to my friend SM Ashik Rahman, as this research would not have come to life without his generous help. I am also grateful to all the participants who took part in this study and shared their perspectives. Finally, I would like to extend my deepest appreciation to my family and friends for their unwavering support and inspiration throughout this journey.

CONTENTS

CHAPTER I.....	1
INTRODUCTION.....	1
LIGHTING VARIABLES AND THEIR IMPACT ON PERFORMANCE AND MOOD.....	2
LIGHT IN AN OFFICE SPACE AND RECOMMENDED PRACTICES.....	3
LIGHT AND CULTURE.....	4
CURRENT STUDY.....	8
CHAPTER II.....	11
METHODOLOGY.....	11
SELECTED CULTURES.....	13
EXPERIMENT SETUP.....	16
LIGHTING SYSTEM CONSTRUCTION.....	28
PARTICIPANTS.....	32
ETHICAL CONSIDERATIONS.....	34
DATA COLLECTION PROCEDURE.....	35
Pre-Experiment Phase.....	36
Experimental Procedure.....	38
Independent & Dependent Variables.....	40
Instruments & Tools.....	43

DATA ANALYSIS	49
CHAPTER III.....	53
RESULTS	53
Visual Performance.....	53
Light Preference.....	58
Visual Performance & Light Preference Correlation	64
DISCUSSION	64
LIMITATIONS	70
FUTURE WORK	72
IMPLICATIONS.....	74
REFERENCES	77
APPENDIX.....	81

TABLES

Table 1. LEGO Structures Created for Experiment Cognitive Task.....	19
Table 2. Test Room, Nine Lighting Scenes.	24
Table 3. RGBW Channel Values for each Light Scene.	30
Table 4. Participant's Distribution Based on Country of Origin.	33
Table 5. Experiment Procedure Summary.	39
Table 6. Illuminance Measurements Across Light Scenes in Test Room.....	45
Table 7. Luminance Measurements Across Light Scenes in Test Room.	46
Table 8. Summary of Instruments & Tools Capturing Lighting Data.	49
Table 9. Built Time Decision-Tree Summary of Exhaust CHAID Splits.	54
Table 10. Built Time Main Effects ANOVA Results Summary. Significant Variables Highlighted in Green.	55
Table 11. Cultural Groups Post Hoc Test Results (Tukey HSD) for Built Time Comparisons.....	56
Table 12. Light Preference Decision-Tree Summary of Exhaust CHAID Splits.	58
Table 13. Main Effects ANOVA Results for Lighting Preference Ratings by Group, Illuminance, and Color Temperature. Significant Variables Highlighted in Green.	60
Table 14. Spearman's Correlation Results Between Lighting Preference and Build Time.....	64

FIGURES

Figure 1. Conceptual Model for the Study.....	13
Figure 2. Waiting Room Experiment Setup.	17
Figure 3. Top View of Test Room Experimental Setup.....	18
Figure 4. Test Room Rubik's LED Recessed - Tunable White Luminaire.	22
Figure 5. Adaptation Space Experimental Setup.....	28
Figure 6. Elevation Diagram of Experiment Lighting Control System.	29
Figure 7. Spectral Power Distribution (SPD) Measurements of each Light Scene. .	32
Figure 8. Location of Illuminance Measurements in the Test Room.	46
Figure 9. Differences in Built Time between Cultural Groups.	56
Figure 10. Estimated Marginal Means of Lighting Preference in Saudi Arabia, Colorado, U.S., and India.	62
Figure 11. Estimated Marginal Means of Lighting Preference Across Cultural Groups, Illuminance Levels, and CCT.....	63
Figure 12. Spectral Power Distribution (SPD) with Common LED Colors within the Visible Spectrum. Retrieved from Luxeon Rebel Color Line. Lumileds. (2024).	83

CHAPTER I

INTRODUCTION

Lighting plays a fundamental role in shaping human perception and experience of indoor environments. In workplaces, particularly office spaces, lighting conditions influence not only visual comfort but also visual and cognitive performance, mood, and overall well-being (Park & Farr, 2007; Küller et al., 2006). While the Illuminating Engineering Society (IES) lighting handbook provides general recommendations on illuminance and correlated color temperature (CCT), they largely overlook cultural factors that shape individual preferences and visual performance. This research investigates the influence of cultural backgrounds on lighting preferences and visual performance in office environments, aiming to inform more inclusive lighting design practices.

As globalization continues to drive workplace diversity, it becomes increasingly important to design environments that accommodate varying perceptual and physiological needs. Existing studies suggest that lighting impacts mood, perception, and preference differently across cultures due to long-term adaptation to local daylight conditions, climate, and historical lighting traditions (Bornstein, 1973). For instance, individuals from northern latitudes may have different preferences and sensitivities to brightness and CCT compared to those from equatorial regions (Knez & Kers, 2000). However, while these preferences are documented, there are no published studies investigating the correlation between

different lighting conditions and their direct impact on visual performance, nor is it clear whether that correlates to their lighting preferences.

LIGHTING VARIABLES AND THEIR IMPACT ON PERFORMANCE AND MOOD

The relationship between lighting and workplace productivity has been extensively studied, with evidence suggesting that lighting conditions affect cognitive flexibility, decision-making, and emotional well-being (Aryani et al., 2020; Baron et al., 1992). Higher illuminance (700 lx–1,500 lx) can enhance visual performance. However, prolonged exposure to it may lead to visual fatigue, whereas illuminance levels below 300 lx are associated with drowsiness and decreased alertness. Studies suggest that 500 lx is appropriate for general office tasks, while more intricate tasks, such as technical drawing, precision-based work, or medical documentation, require up to 750 lx for improved accuracy and concentration (Aryani et al., 2020).

Light intensity affects cognitive performance, particularly in tasks that require continuous concentration. Baron et al. (1992) found that under lower illuminance conditions (150 lx), participants performed better on cognitive flexibility tasks, such as word association exercises and creative problem-solving tasks, compared to those exposed to higher illuminance levels (1,500 lx). This suggests that overly bright environments may reduce cognitive flexibility, thereby limiting an individual's ability to think abstractly and explore alternative solutions.

The intensity of lighting also influences interpersonal behaviors and collaboration. Studies have shown that high-intensity lighting may increase stress

levels, leading to more competitive or avoidant conflict resolution styles. In contrast, lower, warmer lighting encourages collaborative problem-solving and positive workplace interactions (Baron et al., 1992).

CCT plays a significant role in workplace psychology. Warm light (2,700 K–3,000 K) can promote relaxation, while cooler light (4,000 K–6,500 K) can enhance alertness and cognitive efficiency (Aryani et al., 2020). However, excessive exposure to high-CCT lighting (6,000 K and above) can lead to eye strain, irritability, and reduced mood despite its benefits in reducing sleepiness (Baron et al., 1992). Additionally, the human circadian rhythm is highly sensitive to blue-enriched light, meaning that prolonged exposure to high-CCT electric lighting in the afternoon and evening can suppress melatonin production, delay sleep onset, and reduce overall well-being (Veitch et al., 2008).

Lighting variables also affect social engagement and workplace culture. In high-stress environments, such as legal offices or financial trading floors, overly bright and cool lighting can increase tension. In contrast, dynamic and adjustable lighting in creative industries may foster innovation and teamwork.

LIGHT IN AN OFFICE SPACE AND RECOMMENDED PRACTICES

For many individuals, the office is where they spend most of their waking hours as adults. It is expected that this time will be both productive and meaningful, with a workspace that supports their well-being. Office lighting design must balance goals of visual comfort, energy efficiency, and psychological well-being. Research suggests that an optimal office lighting environment requires a

balance of illuminance, CCT, light distribution, and user control (Veitch et al., 2008; Hansen et al., 2022), as lighting acts as a stimulus for cognitive tasks that require prolonged focus (Goodman et al., 2006).

According to the Illuminating Engineering Society (IES) recommended practice for lighting office spaces, some human-centric fundamentals need to be taken into consideration when lighting an office space, including visibility by ensuring sufficient illumination for tasks, comfort by minimizing excessive glare and flicker, mood and well-being through appropriate color temperature, and aesthetic judgment by integrating lighting with the overall office architecture (ANSI/IES RP-1-20, 2022). The IES Handbook establishes guidelines for appropriate light levels and color temperature (CCT) to create an environment that best supports human needs. While these guidelines are intended for general use in an office environment, they could be made more specific to the types of users in various working space types.

Additionally, studies suggest that providing employees with control over their lighting settings significantly improves workplace comfort and productivity. Workstation-specific lighting with dimming controls enables employees to adjust the lighting to their preferred levels, leading to increased satisfaction and efficiency (Veitch et al., 2008).

LIGHT AND CULTURE

Lighting preferences are not universal; they are shaped by cultural background, environmental adaptation, and traditional lighting practices (Madan,

2023; Park et al., 2010). Geographic differences in daylight availability, climate, and architectural history further contribute to regional variations in lighting choices. As Goodman et al. (2006) note, "Preferred lighting conditions depend on individual perception, which is influenced by prior experience, culture, and environment." Several studies, discussed below, have investigated how cultural lighting preferences evolve and their impact on comfort, perception, and workplace efficiency.

One of the cross-cultural studies on illuminance preferences was conducted by Eissa (2015), who compared lighting conditions in Omani and Portuguese-built spaces in Oman. The research aimed to understand how different cultural influences have shaped daylighting strategies in historic architecture and whether these differences continue to influence modern lighting preferences. The study found that modern Omani structures featured higher illuminance levels, ranging from 360 lx to 500 lx. This was attributed to habitual adaptation to extreme sunlight exposure, where Omani inhabitants were accustomed to brighter indoor spaces to compensate for harsh outdoor conditions. In contrast, Portuguese modern spaces in the same region exhibited significantly lower illuminance levels, averaging between 112 lx and 148 lx, aligning more closely with European lighting standards. These findings suggest that prolonged exposure to high daylight intensities affects people's preference for higher indoor modern electric lighting levels. In contrast, individuals from regions with traditional-built spaces with softer

daylight exposure tend to prefer dimmer, more diffused electric lighting conditions (Eissa, 2015).

The effect of CCT on cultural lighting preferences has also been extensively researched. Park et al. (2010) conducted a comparative study on the lighting preferences of North American and South Korean hotel guests to determine how light intensity and color temperature affected comfort, pleasure, and arousal. The study found that North Americans strongly preferred warm, dim lighting in hotel spaces, associating it with relaxation and a sense of coziness. In contrast, South Korean participants preferred bright, warm lighting, describing it as stimulating and energizing. Additionally, the study observed that North Americans disliked bright lighting, associating it with discomfort and sterility. In contrast, Koreans felt discomfort in dim lighting and preferred higher light intensities to maintain engagement and alertness (Park et al., 2010). The results emphasize that cultural lighting preferences are not merely aesthetic choices but are deeply ingrained in societal norms and influenced by exposure to various lighting environments.

Further supporting this idea, Madan (2023) explored seasonal and cultural lighting preferences in Swedish and Indian contexts, analyzing how lighting traditions during Christmas and Diwali shaped people's perceptions of brightness and warmth. The study revealed that Swedes associate indirect, warm lighting with coziness and social bonding, particularly during the long winter months when daylight is scarce. In contrast, Indians prefer bright, colorful lighting arrangements during festive seasons, emphasizing vibrancy, celebration, and spiritual

significance. The study also found that despite globalization and increased access to modern lighting technologies, traditional lighting preferences persisted in both cultures, suggesting that lighting choices are not solely dictated by functionality but also by deeply rooted emotional and symbolic meanings (Madan, 2023).

Another significant study investigating the impact of lighting on mood across various cultural settings was conducted by Küller et al. (2006). This research explored the effects of indoor lighting and color schemes on psychological mood in workplace environments across four countries: Argentina in Tucumán (27° N), Saudi Arabia in the Greater Dammam area (26° N), Sweden in the southern region (56° N), and the United Kingdom in the south (52° N). The researchers discovered that individuals living farther north of the equator (e.g., Sweden and the UK) experienced notable seasonal variations in mood, reporting lower mood levels during winter and improved emotional states in summer. In contrast, this seasonal fluctuation was not observed in Argentina and Saudi Arabia, where daylight duration remains more consistent throughout the year. The study also revealed that the perceived brightness of an indoor space significantly influenced mood more than actual measured illuminance levels. Employees reported their lowest mood levels when the lighting was perceived as too dark, with mood improvement when the lighting was "just right" but declining again when it was perceived as too bright (Küller et al., 2006). Interestingly, these findings suggest that subjective lighting perception has a greater impact on emotional states than actual light

measurements, highlighting the importance of psychological comfort in lighting design.

Another critical factor in cultural lighting differences is the relationship between lighting preferences and cognitive function. Baron et al. (1992) conducted a study examining the impact of lighting conditions on cognitive flexibility, interpersonal behavior, and problem-solving. The research found that participants, primarily U.S. college students, exposed to warm-white, low-illuminance environments (150 lx at ~3000 K) exhibited greater cognitive flexibility and higher levels of cooperation in workplace interactions. Conversely, participants in cool-white, high-illuminance environments (1500 lx at ~5000 K) demonstrated more rigid thinking patterns and a greater tendency to avoid conflict resolution. These findings suggest that lighting not only affects comfort but also impacts social behavior and cognitive adaptability, which has significant implications for global office design and workplace productivity.

CURRENT STUDY

Past research acknowledged differences in preference regarding lighting intensity and apparent color based on cultural backgrounds in various applications; however, there is no precedent information about the relationship of lighting scene preference and visual performance in a workplace environment. One study examined the impact of lighting on mood across different cultures in an office environment, but it did not investigate the relationship with visual performance (Küller et al., 2006). The study also primarily focused on latitude-based

comparisons rather than directly investigating cultural background as a predictor of lighting preference and performance.

Our study aims to expand upon previous research by examining both same-latitude and cross-latitude cultural comparisons, allowing for a deeper exploration of the influence of cultural background on workplace lighting preferences and performance.

This study addresses the gaps in past studies by asking the research questions:

1. *Does cultural background predict the difference in performance in visual environments that vary in light intensity and apparent color?*
2. *Does cultural background predict the difference in preference in visual environments that vary in light intensity and apparent color?*
3. *Is there a correlation between light preference and visual performance in visual environments that vary in light intensity and apparent color?*

To address these research questions, we employed a repeated-measures experimental design to investigate the impact of cultural background on lighting preferences and visual performance in an office-like setting. The repeated measures approach allows each participant to experience multiple lighting conditions, ensuring a within-subject comparison of preferences and performance across different illuminances and CCT. By having each person serve as their own control, this design reduces differences between individuals, making it easier to detect

whether changes in lighting and cultural background truly impact performance and preferences.

The study consisted of nine lighting scenes, systematically varying in illuminance and CCT. Participants completed a visual performance task (LEGO model building) under six of the nine lighting conditions, and their task completion times were recorded. Additionally, subjective lighting preferences were assessed using a 7-point Likert scale questionnaire.

To ensure validity and reliability, the experiment was conducted in a controlled office-like lighting laboratory at the University of Colorado Boulder with a 30-second adaptation period with typical lighting conditions used between each lighting scene to prevent sudden exposure effects, minimize carryover effects, and environmental factors such as room layout, task difficulty, and participant seating position remain constant throughout the experiment.

This research design ensures that the study captures quantitative data, including performance-based and numerical survey-based data, providing a comprehensive understanding of how cultural background influences lighting perception and workplace performance.

CHAPTER II

METHODOLOGY

In this study, culture is defined by regional differences, including environmental factors such as latitude and daylight conditions, cultural backgrounds, traditions, and lighting practices shaped by regional and cultural influences. These factors shape how individuals interact with light, influencing both their visual preferences and performance.

This study focused on participants from three regions: the United States (Colorado), Saudi Arabia, and India. These regions were selected based on the cultural factors mentioned in **SELECTED CULTURES**. While cultural factors influence lighting interactions, this study specifically focused on two primary lighting parameters: correlated color temperature (CCT), which ranges from warm to cool white light, and illuminance levels, which range from low to high light intensities. Further details on lighting terminologies can be found in Appendix 1.

Visual performance in the experiment was measured using a performance task that involved building a LEGO structure. The LEGO building task in the experiment involves visual and cognitive performance, as it requires participants to visually identify and manipulate pieces while also engaging memory, attention, and spatial reasoning to complete the model accurately. Participants were required to construct a LEGO structure using 20 bricks while following simple instructions. This method enabled us to evaluate how participants from diverse cultural

backgrounds performed under various lighting conditions and assess the impact of these conditions on their performance.

Additionally, the study explored differences in light preferences through a survey administered after participants completed the cognitive task, gathering feedback on their perceived lighting conditions. Other variables that could potentially influence visual performance were considered in case there was no direct effect of light conditions or cultural differences on visual performance. These variables included sleep patterns, daylight exposure, gender, mood, and visual impairments, all of which were self-reported. A conceptual model summarizing the factors considered in the study, including both independent and dependent variables, is presented in Figure 1. The primary objective was to determine whether there were any differences in visual performance among participants and to investigate whether there were any differences in light preferences among participants, as well as to examine whether a direct correlation exists between visual performance and light preferences.

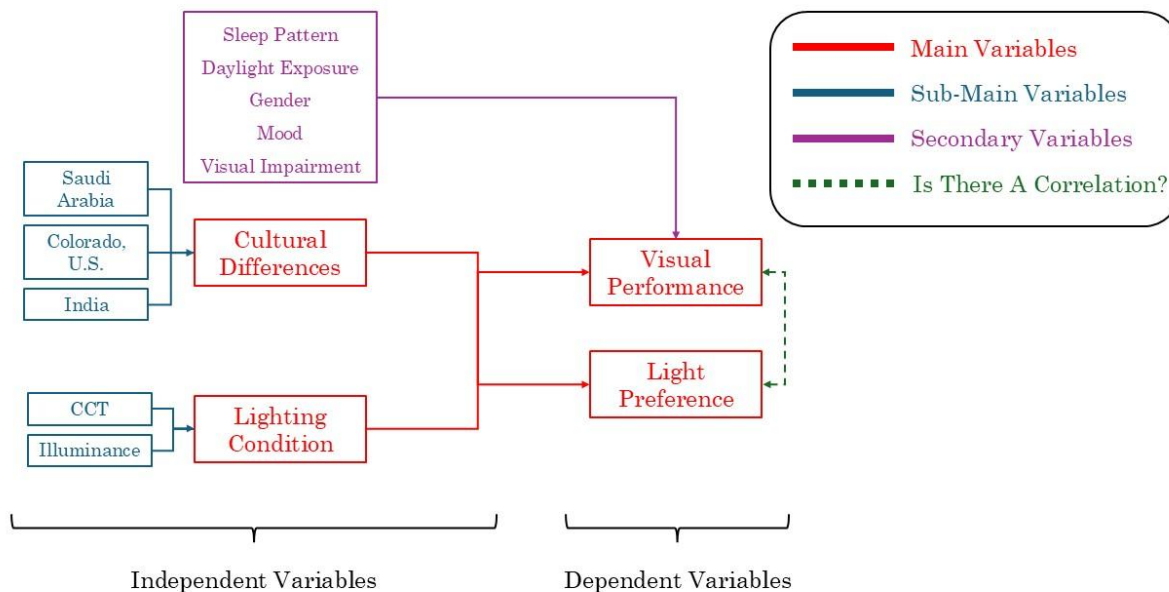

Figure 1. Conceptual Model for the Study.

SELECTED CULTURES

This study examines three different regions — the United States (specifically, Colorado), Saudi Arabia, and India — to explore variations in light preferences and visual performance. These regions were selected based on their environmental conditions, cultural influences, and lighting practices, which shape how individuals perceive and interact with light. Additionally, we selected two regions with similar latitudes and one that differs.

Colorado, USA, located in the western United States, has a diverse topography, ranging from the Rocky Mountains to the Great Plains. Positioned between latitudes 37° N and 41° N and longitudes 102° W and 109° W, the state experiences significant seasonal variations in daylight duration, with extended daylight hours in summer and shorter daylight hours in winter. These fluctuations

may contribute to variations in light level preferences and correlated color temperature (CCT). Lighting practices in the United States have evolved toward energy-efficient solutions, with LED fixtures now dominating the market. In Colorado, lighting design adheres to the IES recommendations, typically maintaining CCT values between 3,000 K and 4,500 K in office spaces and illuminance levels between 300 lx and 500 lx. However, variations in CCT and illuminance can be influenced by climate conditions and national energy efficiency initiatives. Furthermore, sustainability standards such as LEED and WELL have been widely adopted, promoting lighting strategies that prioritize occupant productivity, comfort, and well-being. These standards encourage high-quality lighting while advocating for reduced illuminance levels to lower energy consumption (LEED BD+C, n.d.; WELL v2, 2024).

Saudi Arabia, located in the Middle East, spans most of the Arabian Peninsula, extending between latitudes 16° N and 32° N and longitudes 34° E and 56° E. Its hot desert climate results in high solar exposure year-round, leading people to spend most of their time indoors. The country's consistent climate and daylight conditions may contribute to relatively stable preferences in light levels and CCT.

Environmental factors influence the preferences for artificial lighting in indoor spaces. While daylight is utilized where possible, modern lighting solutions, including fluorescent and LED fixtures, have been widely adopted to improve energy efficiency. A study by Najjar et al. (2023) found that workers in Saudi Arabia

preferred natural daylighting and cool white artificial lighting (4,500 K–6,500 K) with high intensity (750 lx–1,000 lx) in work environments. Conversely, warm white light (2,700 K–3,500 K) was favored in private spaces, which may be linked to cultural and religious influences. For example, religious spaces such as mosques and prayer areas predominantly use warm white lighting (2,700–3,500 K) with low illuminance levels (100 lx–300 lx) to create a serene atmosphere.

India, located in South Asia, spans latitudes from 8° N to 37° N and longitudes from 68° E to 97° E. The country features a diverse climate, ranging from tropical to subtropical, with high solar exposure and variations in seasonal daylight. On average, workers spend about 60% of their workdays in office environments (Pathak et al., 2015), where both natural and artificial lighting- including fluorescent and LED- significantly influence workplace lighting preferences. A study conducted in 15 randomly selected office spaces in Nagpur, a city characterized by a hot and dry climate, found that seven out of ten offices reported satisfaction with low illuminance levels and cool white light (<200 lx), suggesting employees had adapted to dim lighting conditions (Pathak et al., 2015). Although employees adapted to the dim light, daylighting was also incorporated, resulting in a brighter work environment. In most building programs in India, the use of moderate to high illuminance around 500 lx to 750 lx with cool color temperatures is the predominant approach to lighting design, with 6500 K being specified in office environments. During celebrations like Diwali, colorful and bright lights are

employed, highlighting vibrancy, celebration, and spiritual significance (Madan, 2023).

In summary, the three regions show distinct preferences in illuminance and correlated color temperature (CCT). U.S. offices (Colorado) typically use 300 lx to 500 lx at 3,000 K to 4500 K, aligning with IES standards. Anecdotally, Saudi Arabian workspaces typically favor high illuminance ranging from 750 lx to 1,000 lx with cool white light, ranging from 4,500 K to 6,500 K. while India typically use moderate to high illuminance output (500 lx–750 lx) with cool color temperature (6500 K).

EXPERIMENT SETUP

The experiment was conducted in the lighting laboratory located at the University of Colorado Boulder's Engineering Center. The experimental setting consisted of three main spaces: the waiting room, the test room, and the adaptation space. The waiting room is the first space of the experimental setup, and it was set up to include a chair and a table where participants sat before the experiment began. A laptop, LEGO bricks, and a consent form were provided on the table. A white lab coat was also provided for participants to wear before entering the test room. The lighting conditions in the waiting room included direct/indirect linear pendant light fixtures with a CCT of 4000 K. The horizontal illuminance level on the task surface was set to 350 lx, while vertical illuminance at the eye level was 240 lx these conditions aimed to mimic general U.S. lighting conditions in workplace environments. The luminance at the center of the computer screen with

white pixels, which was measured for documentation, was an approximate average of 460 cd/m^2 . The waiting room lighting environment was controlled by setting the light conditions through the room dimmer and closing all doors to prevent daylight ingress (Figure 2).

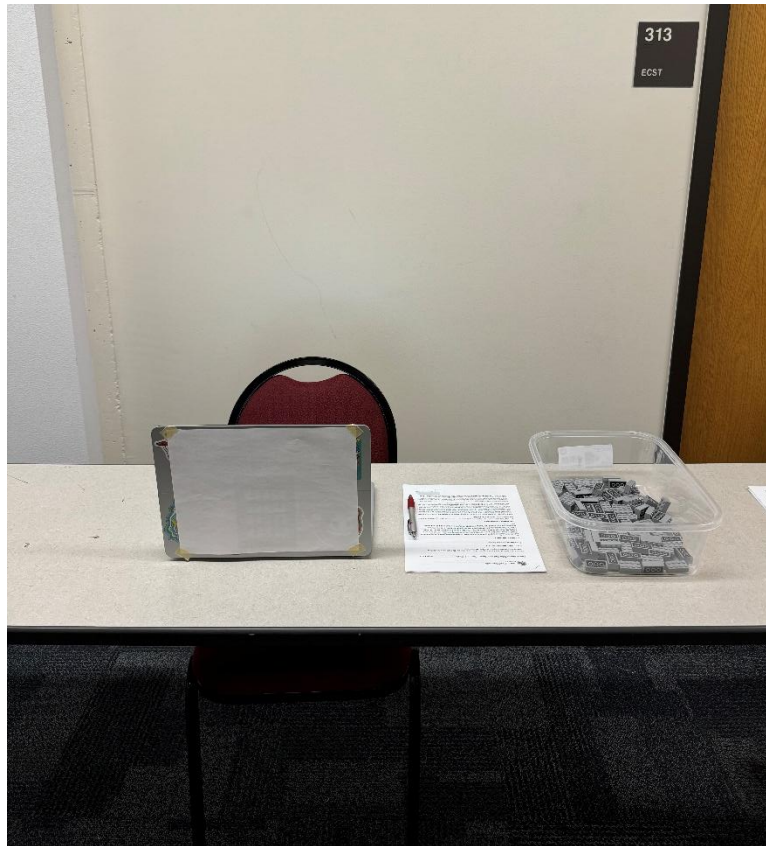

Figure 2. Waiting Room Experiment Setup.

The second space in the experimental setup was the test room where the experiment took place. The room was designed to resemble an office-like environment, measuring $3.0 \text{ m} \times 2.1 \text{ m} \times 2.7 \text{ m}$ ($10 \text{ ft} \times 7 \text{ ft} \times 9 \text{ ft}$). It featured white gypsum board walls, a dark grey carpet, and a white ceiling with recessed downlights. The reflectance of each surface was determined by first measuring the luminance of a standard surface with 100% reflectance, then comparing it to the luminance of the target surface to calculate reflectance using luminance ratios, the



equation used can be seen in Appendix 2. The measured reflectance values were 50% for the walls, 10% for the floor, and 65% for the ceiling. A brown wooden desk with a reflectance of 20% was placed at the center of the room, accompanied by a black chair. The desk served as the task surface, positioned 0.68 m (27 in.) above the floor where the experiment task was conducted. The experiment instructions (Appendix 3), pen, bell, and wooden stand for holding the LEGO instructions were provided on the desk (Figure 3). Six labeled boxes (Scene #1 to Scene #6) were stacked on the right side of the table. Each box contained LEGO bricks, instructions for building the structure, and the experiment questionnaire. The LEGO instructions can be found in (Appendix 4). The test room had a controlled and standardized lighting environment, ensuring that there was no daylight ingress and that the environment was the same for all participants.





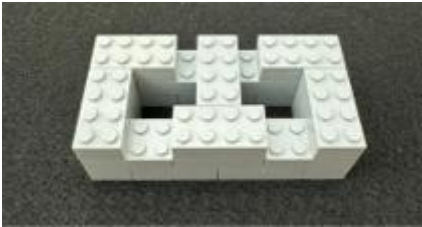
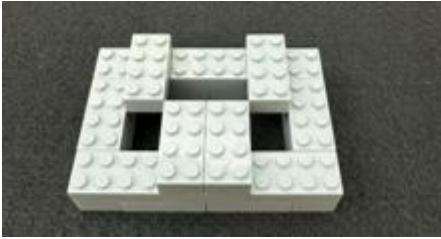

Figure 3. Top View of Test Room Experimental Setup.

To ensure the performance task was equal across participants, all nine LEGO structures consisted of 20 grey bricks to be constructed. The instruction cards used simple yet comprehensive wording to minimize any confusion during the experiment. The instruction pages varied in length from five to seven pages, depending on the structure. Each LEGO structure was labeled with a different letter (Table 1). The nine LEGO structures are randomized so that each participant constructed six of the nine structures in the experiment.

Table 1. LEGO Structures Created for Experiment Cognitive Task.

LEGO Alphabet Format	LEGO Structure Shape
LEGO A	
LEGO B	
LEGO C	

LEGO D	
LEGO E	
LEGO F	
LEGO G	
LEGO H	

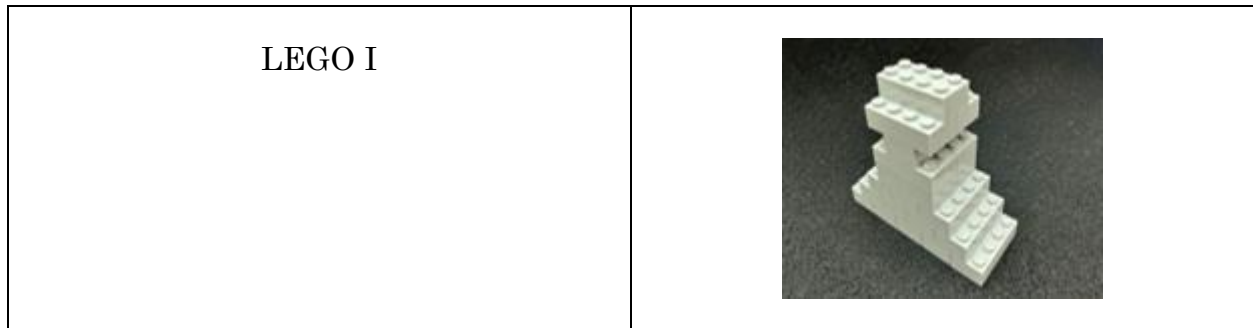

The lighting fixture used in the test room was an Acuity Brands Rubik Architectural Recessed, which is an LED-based lighting system designed for dynamic, tunable white illumination. The fixture used in the experiment room was a 9-cell (9CS), with each unit measuring 0.61 m x 0.61 m (2 ft x 2 ft). A total arrangement of 12 covered 3.34 m² (36 ft²) of the ceiling, illuminating the entire test room (Figure 4). The housing is constructed from 20-gauge cold-rolled galvanized steel with a high-reflectance matte white finish. The fixture features acrylic shielding with 90% transmissivity, which reduces glare and ensures uniform light distribution while maintaining the fixture's efficacy. It provides tunable white settings with a CRI of 90+ while maintaining the nominal lumen output for each cell. The DMX-compatible drivers are eldoLED with dimming to less than 1%. Further fixture details are provided in Appendix 5.



Figure 4. Test Room Rubik's LED Recessed - Tunable White Luminaire.

The test room included nine different lighting conditions (Table 2). The illuminance consisted of three varying levels: 150 lx, 450 lx, and 750 lx. To ensure consistency, all illuminance levels included the same three correlated color temperatures: 2,700 K, 4,000 K, and 6,500 K. The baseline lighting condition was 450 lx with a CCT of 4,000 K, serving as the middle ground with average light conditions in workplace environments. This scene represents the commonly used neutral-white lighting found in modern office settings. To explore how deviations from this standard influenced visual preference and performance, the lower threshold was defined as 150 lx with a CCT of 2,700 K; this setting represents a dim, warm-white environment, reflecting lower lighting levels. The upper threshold was defined as 750 lx with a CCT of 6,500 K; this setting represents a bright, cool-white environment. The baseline lighting condition with the two ends of the thresholds (450 lx with a CCT of 4,000 K, 150 lx with a CCT of 2,700 K, and 750 lx with a CCT of 6,500 K) were applied to be present through the experiment for all



participants while the rest of the lighting scenes were randomized between the participants through a randomization function in Excel.

Each participant experienced six of the nine possible lighting scenes. The lighting scenes were counterbalanced to control for potential biases that arise from the order in which participants encounter experimental conditions. This approach ensured that participants experienced a broad range of lighting conditions in varying order. A partial counterbalancing was achieved by first dividing the main participant groups (Colorado, U.S., Saudi Arabia, and India) into subgroups. Each main group was further split into five subgroups, labeled according to the country and a sequence number. Each subgroup consisted of six participants who were exposed to six lighting scenes, which included three predetermined lighting conditions and three randomized lighting conditions. Both lighting conditions and LEGO sets were partially counterbalanced. Due to the low participants rate discussed in PARTICIPANTS, we have only included participants one and two in the five subgroups.

The randomization of light scenes and LEGO sets was conducted using an Excel-based randomization function (Appendix 6). This counterbalancing strategy, similar in principle to a partial Latin Square Design, allowed for structured variation in lighting conditions while minimizing the influence of specific LEGO structures on performance. Additionally, randomizing the LEGO sets helped reduce potential learning effects, where participants might improve simply by getting

better at the task over time rather than due to the lighting condition itself. The detailed table outlining the randomization is provided in Appendix 7.

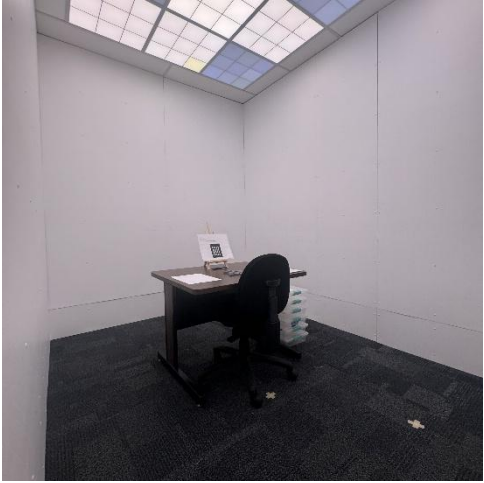
Table 2. Test Room, Nine Lighting Scenes.

Scene Number	Illuminance (lx)	CCT (K)	Test Room Appearance
1	150	2700	
2	450	2700	

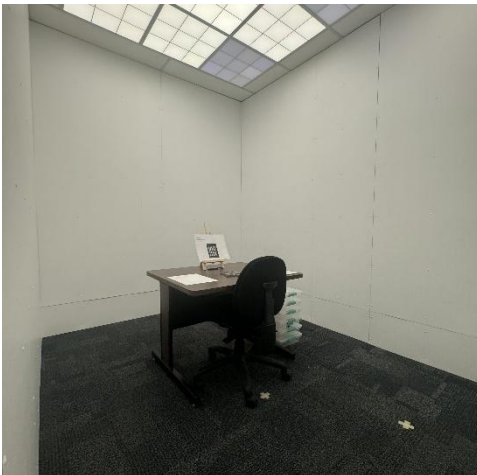
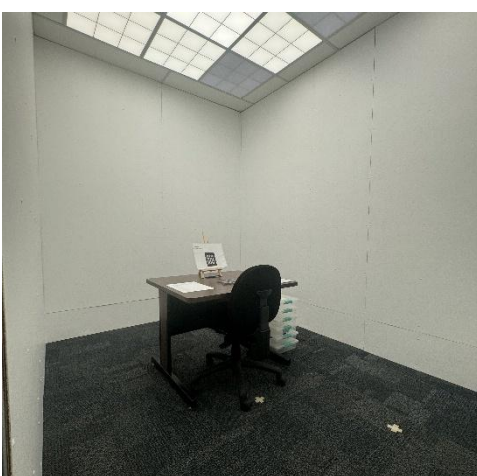
3	750	2700	
4	150	4000	
5	450	4000	

6	750	4000	
7	150	6500	
8	450	6500	

9	750	6500	
---	-----	------	------------------------------------------------------------------------------------

The final space of the experimental setup included the adaptation space. The space was located outside the experiment room, where a chair is situated, allowing participants to sit between each light scene. The lighting conditions included the use of 4000 K indirect linear pendants. The horizontal illuminance level on the task surface was equal to 350 lx, while the vertical illuminance at the eye level was 240 lx. During the experiment, the adaptation lights were turned off to avoid affecting the lighting conditions inside the test room and were turned on between the transitions of each light scene. The adaptation space was controlled by not allowing any daylight ingress. This space allowed us to mitigate bias by reducing participants' notice of direct changes in illuminance and CCT between experimental scenes (Figure 5).



Figure 5. Adaptation Space Experimental Setup.

LIGHTING SYSTEM CONSTRUCTION

A personal computer and a dimmer (DMX controller) were used to control the color output of the LED fixtures. The computer was connected to the DMX system, which was then linked to the LED fixtures in a daisy-chain configuration. This setup used a single DMX cable to connect all eight light fixtures sequentially, ensuring that signals were transmitted from the controller to the last fixture, integrating all eight grids (Figure 6).

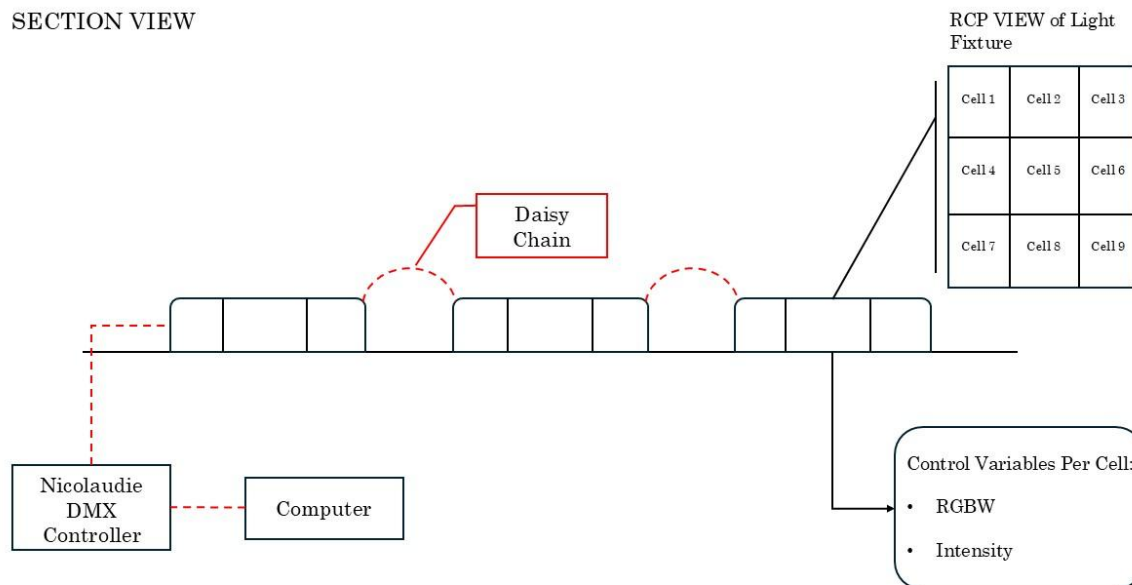

Figure 6. Elevation Diagram of Experiment Lighting Control System.

Each LED fixture contained nine cells with RGBW (Red, Green, Blue, and White) channels. RGBW is a four-channel lighting system, where each channel is controlled individually through the personal computer, allowing for precise intensity adjustments. The intensity of each RGBW channel was modified using a scale from 0 (low intensity) to 255 (high intensity). For example, increasing the intensity of the Red (R) channel increased the red hue of the LED fixture. The White (W) LED served as the primary contributor to white light, while the RGB LEDs fine-tuned the spectrum.

The digital control system sent signals from the DMX controller to the RGBW channels, determining the channel intensities to be displayed. A table detailing the RGBW values for each lighting scene is presented in Table 3. The RGBW channel settings were configured for each lighting scene based on an educated guess-and-

check approach, taking into account the fundamentals of RGBW color mixing to achieve the desired illuminance and CCT for each scene. After configuring the RGBW channels for each lighting scene, spectral power distribution vertical measurements at the eye level were taken (Figure 7), illustrating the visible spectrum and its corresponding color ranges for each RGBW channel.

The DMX system used in this experiment was the Nicolaudie SELSA-U9. DMX is a standardized digital communication protocol widely utilized in theatrical, architectural, and entertainment lighting (Appendix 8). It enables the control of multiple lighting fixtures and effects through a single controller, allowing for real-time adjustments needed to move between experimental scenes (KL DMX White Paper, 2022; Pharos DMX Series Article, 2022).

Table 3. RGBW Channel Values for each Light Scene.

RGBW Channels	Scene Number 1	Scene Number 2	Scene Number 3
R-Channel	26	79	132
G-Channel	11	32	53
B-Channel	3	8	13
W-Channel	12	37	63
RGBW Channels	Scene Number 4	Scene Number 5	Scene Number 6
R-Channel	11	33	55
G-Channel	11	33	55
B-Channel	5	13	22
W-Channel	15	46	77
RGBW Channels	Scene Number 7	Scene Number 8	Scene Number 9
R-Channel	11	33	55
G-Channel	11	33	55
B-Channel	5	13	22
W-Channel	15	46	77

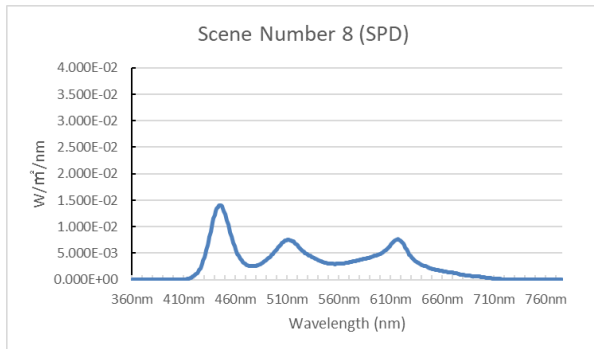
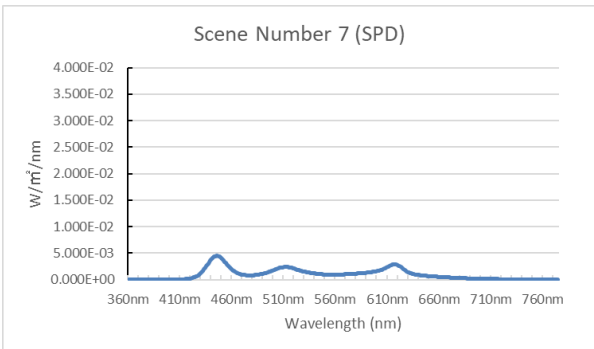
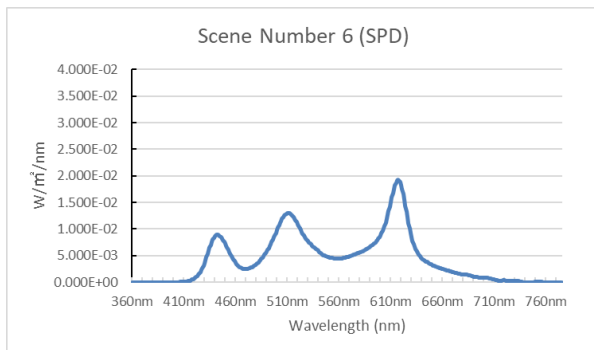
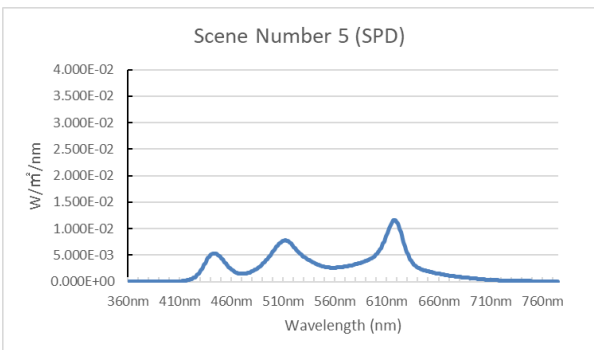
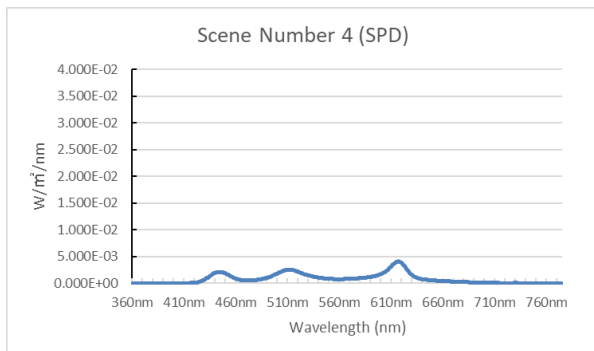
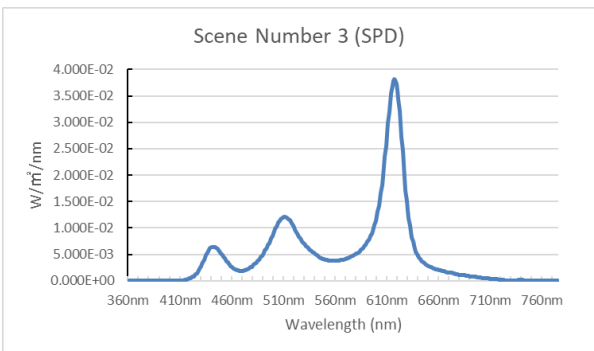
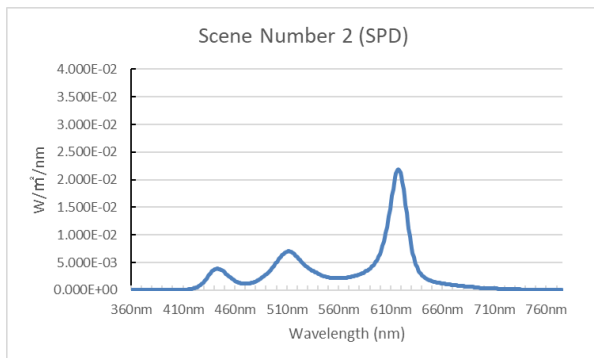
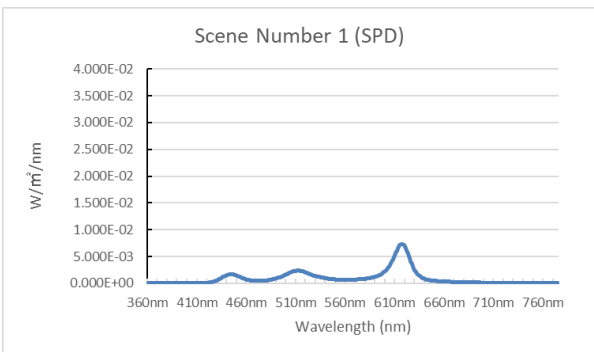

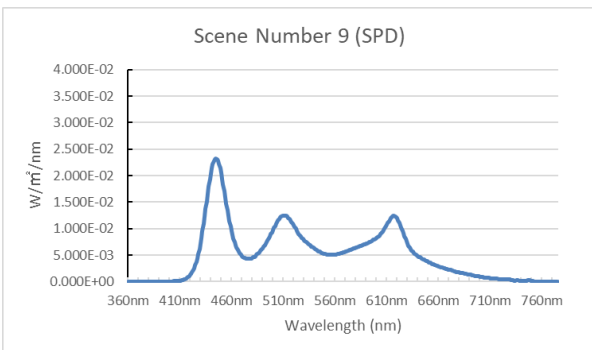

Figure 7. Spectral Power Distribution (SPD) Measurements of each Light Scene.

PARTICIPANTS

A total of 27 participants took part in the study, divided into three cultural groups representing three countries: the United States (Colorado), Saudi Arabia, and India. Due to low participation rates from two initially selected regions, recruitment was expanded to include additional countries:

- Participants from Kuwait were grouped with the Saudi Arabian cultural group.
- Participants from Bangladesh (latitude $23^{\circ}\text{N} \pm 10^{\circ}$) were grouped with the Indian cultural group.

Kuwait and Bangladesh were included in these groups due to similarities in climate, cultural traditions, and historical architectural lighting. These regions share comparable daylight exposure patterns, architectural lighting traditions, and common artificial lighting preferences, justifying their inclusion in the study.

Based on participants' reported hometowns, an estimated latitude range was determined for each cultural group:

- United States (Colorado): 38° – 40° N
- Saudi Arabia and Kuwait: 21° – 30° N

- India and Bangladesh: 17°–23° N

The final distribution comprised nine participants from the United States (Colorado), ten from Saudi Arabia/Kuwait, and eight from India/Bangladesh (Table 4). All participants were college students at the University of Colorado Boulder. To control for age-related variations in light perception and visual performance, the study limited participation to individuals aged 18–30 years. All genders were included, with a final distribution of 52% male and 48% female.

Table 4. Participant's Distribution Based on Country of Origin.

Cultural Groups	Number of Participants enrolled
United States (Colorado)	9
Saudi Arabia / Kuwait	10
India / Bangladesh	8

To minimize adaptation effects, participants from non-U.S. cultural backgrounds were required to have lived in the United States for no more than five years. While there is no universally agreed-upon threshold for full perceptual adaptation, limiting the residency period helps ensure that responses reflect participants' original cultural frameworks rather than preferences formed through acculturation or environmental conditioning in the U.S. Participants' knowledge of lighting design and illumination engineering varied, but this was not considered a variable in the study. Additionally, data on participants' visual impairments were collected, and those with conditions affecting vision (e.g., color vision deficiency, uncorrected vision impairments) were excluded to ensure consistency in visual performance assessments.

Participants were recruited through announcements in classes, emails to students, outreach to cultural clubs, and promotion through the English language program at CU Boulder. To prevent undue influence, recruitment materials explicitly stated that participation was voluntary, unrelated to coursework, and had no penalties for non-participation.

ETHICAL CONSIDERATIONS

This study was conducted in accordance with the ethical guidelines for research involving human subjects. It was approved by the Institutional Review Board (IRB) at the University of Colorado Boulder under protocol number 24-0434. All participants were provided with an informed consent document before the study, which outlined the research purpose, procedures, potential risks, and their right to withdraw at any time without consequence (Appendix 9). Consent was obtained with a signature during the participant's visit to the experiment.

To protect participant privacy and confidentiality, all collected data were de-identified by removing personal identifiers before analysis. Data were securely stored on university-approved encrypted servers (Qualtrics), and access was restricted to authorized researchers only. In addition, the study adhered to strict data protection protocols, ensuring that responses remained confidential and were used solely for research purposes.

The potential risks to participants were minimal, primarily involving temporary discomfort due to lighting conditions. To mitigate this, participants were instructed to immediately notify the research team if they experienced discomfort,

eye strain, or dizziness, and they had the option to discontinue participation at any time. Additionally, breaks were provided between each lighting scene, and participants were given a 30-second adaptation period to prevent sudden exposure effects.

To ensure voluntary participation and avoid undue influence, recruitment materials emphasized that participation was optional, unrelated to coursework, and carried no academic or personal penalties for non-participation. Participants received snacks, though some received extra credit if their course instructors permitted it.

By adhering to these ethical considerations, this study ensured that participants' rights, safety, and confidentiality were maintained while contributing valuable insights into the cultural influences on lighting preferences and workplace performance.

DATA COLLECTION PROCEDURE

The study's data collection was divided into two phases: the pre-experiment phase and the experimental procedure. In the pre-experiment phase, participants were asked to answer a demographic questionnaire (Appendix 10) and a one-day PANAS-SF mood log (Appendix 11). During the experimental procedure phase, information on visual performance and light preferences was gathered (Appendix 12).

Pre-Experiment Phase

An email was sent to each participant, which included a sign-up sheet allowing them to select a time slot for participation in the experiment. The time slots provided flexibility for the participants, ensuring that each participant completed the experiment individually, without interaction with other participants. The email also included a demographic questionnaire designed to collect essential background information about participants to contextualize their responses to the study. The questionnaire began with basic identification questions, including name and University of Colorado email address, to maintain organization. The questionnaire then gathers demographic data, such as age, gender, and locations where participants have lived, providing insight into diverse backgrounds and experiences. Academic information is also recorded, specifically whether the participant is a student and their major, to understand any potential influences of educational background. Additionally, the questionnaire includes questions about vision and light sensitivity, assessing whether participants wear corrective eyewear, have visual impairments, or experience dizziness due to changes in lighting to ensure that any potential factors affecting visual perception are known.

To explore cultural and environmental influences, the questionnaire includes an optional question about religious affiliation, allowing participants to disclose any relevant background information that may impact their responses. Furthermore, it assesses participants' knowledge and preferences regarding lighting, determining whether they have prior expertise in lighting design and gathering information

about their typical work or study lighting conditions. A section on circadian rhythm and sleep patterns explores participants' daily activity levels, usual wake and sleep times, sleep quality, and recent sunlight exposure, as these factors can affect performance in lighting-related studies. Lastly, a pre-experiment compliance question asks participants to maintain a consistent sleep schedule before the experiment and acknowledge their understanding of this recommendation. Overall, this questionnaire ensures that information about visual conditions, lifestyle habits, and prior lighting knowledge were gathered as potential tertiary variables for consideration. Not all questions were used in this study, focusing only on those that would help address the secondary variables mentioned in the Conceptual Model for the Study.

The email included a one-day mood log that utilizes a 7-point Likert scale to assess participants' moods recorded on the day of the experiment using PANAS-SF. The Positive and Negative Affect Schedule (PANAS) is a well-established tool for measuring mood and affect (Watson, Clark, & Tellegen, 1988). Participants will rate their mood based on 10 Positive Affect (PA) items (interested, excited, strong, enthusiastic, proud, alert, inspired, determined, attentive, active) and 10 Negative Affect (NA) items (distressed, upset, guilty, scared, hostile, irritable, ashamed, nervous, jittery, afraid). This data will serve as a baseline reference, allowing us to evaluate mood variations and identify potential outliers that may influence performance during the experiment.

Experimental Procedure

Each participant began in the waiting room, where the primary investigator greeted them and instructed them to watch a four-minute video that introduced the study, explained the procedure, and demonstrated a LEGO building example not included in the actual experiment (Appendix 13). LEGO blocks were provided for practice. After the video, participants were asked if they had any final questions before signing the consent form. This phase took approximately eight minutes, including an additional seven-minute buffer for participants who needed to complete the pre-experiment demographic questionnaire or mood log if they had not already done so.

Next, participants entered the test room, where they completed six trials under different lighting scenes. First, participants picked a box labeled Scene #1, which contained LEGO bricks, instruction cards, and the experiment questionnaire. Then, they set up the LEGO bricks on the desk in front of them, placed the instruction cards on the wooden stand and the experiment questionnaire on the side, and then signaled readiness by ringing the bell provided on the desk. A timer records the time taken to build the structure, and the time is recorded after the participants ring the bell again, indicating that they have finished the building task. After they submitted their responses to the experiment questionnaire, participants rang the bell for a third time to indicate the completion of the first trial. The primary investigator then activated a 30-second adaptation phase, during which participants sat in the transition space before re-entering the test room for

the subsequent trial. This procedure is repeated six times across different lighting conditions, with a maximum experiment duration of 60 minutes. A summary table of the procedure is provided below (Table 5). Following the completion of all six trials, participants were debriefed, and their responses were logged for analysis.

The following section outlines the data collection methods employed to assess visual performance, lighting conditions, and subjective preferences.

Table 5. Experiment Procedure Summary.

	Procedure	Tools	Location	Duration
Pre-experiment Phase				
Demographic Questionnaire	Answer questions related to: <ul style="list-style-type: none"> • demographics • academic background • vision and light sensitivity • sleep patterns • circadian preferences • lighting environment • Prior lighting design knowledge 	<ul style="list-style-type: none"> • Online questionnaire – Qualtrics 	N/A	N/A
One-Day Mood Log	Answer mood-related questions	<ul style="list-style-type: none"> • PANAS-SF Online questionnaire – Qualtrics 	N/A	N/A
Experimental Procedure				
Waiting Room	<ol style="list-style-type: none"> 1. Watch the instruction video 2. Practice with LEGO bricks 	<ul style="list-style-type: none"> • Laptop • LEGO bricks • Consent form • Pre-experimental 	University of Colorado Boulder	15 minutes

	<ol style="list-style-type: none"> 3. Ask last-minute questions 4. Sign the consent form 5. Extra to complete the pre-experiment demographic questionnaire and day log 	<p>demographic questionnaire</p> <ul style="list-style-type: none"> • Day Log form • Pen • Desk • Chair 		
Test Room	<ol style="list-style-type: none"> 1. Build a LEGO structure 2. Answer experiment questionnaire 3. Sit in adaptation space for 30 seconds 4. Repeat six times 	<ul style="list-style-type: none"> • 20 LEGO bricks • Instructions • Experiment questionnaire • Bell • Wooden stan • Pen, • Desk • Chair 	University of Colorado Boulder	45 minutes

Independent & Dependent Variables

Experimental data capture included two main objectives: visual performance metrics and environmental measurements, as well as one main subjective-objective, individual feedback. Performance metrics included measuring the time taken to complete building the LEGO structure. Subjective feedback included questions about participants' light preferences, including questions about the perceived brightness and dimness, apparent color, and overall preference of the light scene. The environmental measurements included measuring the illuminance, CCTs, and luminance for each lighting scene. In this study, individual feedback questions used

the overall likeness of the light scene as the sole measurement to answer the second research question, excluding perceived brightness, dimness, and likeness of CCT, which maintained the main objective of the second research question.

The independent variable in the study includes the cultural differences of each participant, representing different geographic, climatic, and traditional origins (United States (Colorado), Saudi Arabia/Kuwait, India/Bangladesh). The other independent variable includes the lighting condition of each lighting scene, encompassing changes in illuminance (lx) and CCT (K). These independent variables are our primary objective in understanding how different cultures interact with light in an office-like space. The dependent variable in the study includes each participant's light preferences in the experiment. Visual performance is another dependent variable influenced by cultural differences, light conditions, and light preferences.

To account for potential influencing factors beyond the primary independent variables, several additional independent variables that could affect participants' performance and light preferences were considered. Sleep patterns were examined for the day of the experiment, as individuals with disrupted or inconsistent sleep cycles may experience poor cognitive performance, including deficits in memory, attention, and executive function (Weinhouse & Devlin, 2022). Participants were advised to sleep for at least seven hours per night for three consecutive days prior to their experiment day. A study on sleep restriction found that individuals who slept fewer than four hours per night experienced continuous degradation in performance

without stabilization. In contrast, those who slept between five and seven hours per night initially showed performance declines but eventually reached a stable, though reduced, level of function (Belenky et al., 2003).

In addition to sleep patterns, daylight exposure before the experiment was documented, as research has shown that it can enhance concentration, alertness, and cognitive flexibility (Küller et al., 2006). Additional research suggests that workers exposed to greater daylight experience improved sleep quality and wake up feeling more refreshed, which in turn enhances workplace productivity (Veitch et al., 2008). Morning daylight exposure has also been found to help maintain steady energy levels throughout the day, reducing mid-afternoon sluggishness and enhancing sustained attention (Baron et al., 1992).

Beyond sleep and daylight exposure, gender differences in lighting preferences were noted. Research has revealed significant variations in mood response, cognitive performance, and visual comfort among individuals based on gender. Küller et al. (2006) found that women exhibited more substantial mood fluctuations under bright lighting conditions, while men's emotional responses remained more stable regardless of illuminance levels. Similarly, Knez and Kers (2000) observed that younger women (aged 18–35 years) were more affected by cool lighting (5,000 K), whereas men's mood remained relatively unchanged across different lighting conditions. Kwallek et al. (1996) further examined the role of color and brightness, finding that women were more sensitive to high-saturation colors

and bright environments. In contrast, men were less affected by color saturation but performed better in higher illuminance settings.

Beyond gender differences, participant's moods were also tracked through the one-day log, as emotional states can influence task engagement, visual environment (light condition), and overall visual comfort (Küller et al., 2006; Baron et al., 1992; Veitch et al., 2008). Additionally, visual impairments such as color blindness, low vision, and cataracts were documented to assess whether variations in visual acuity impacted participants' experiences and task performance. While these factors were not primary independent variables, they were carefully monitored to ensure a more comprehensive understanding of individual responses to different lighting conditions.

Instruments & Tools

To ensure accurate data collection, a combination of objective measurement tools and subjective evaluation instruments was employed to assess lighting conditions, visual performance, and participant preferences. Illuminance measurements (in lx) were obtained using a Konica Minolta T-10A Illuminance Meter (Appendix 14) at the horizontal plane at the desk (task surface), vertical plane at the eye level looking at the task, LEGO instruction cards, and all four walls in the test room. This ensures consistent readings across all lighting conditions during the experiment; for instance, lighting scenes with the same illuminance output but different color temperatures will have approximately the same recorded illuminance readings (Table 6). The location of the illuminance

measurement can be seen in Figure 8. The Konica Minolta CL-500A Illuminance Spectrophotometer (Appendix 15) was used to capture the SPD of the light sources, allowing for precise calculations of CCT. To measure surface luminance, a Konica Minolta LS-150 Luminance Meter (Appendix 16) was utilized, while a digital single-lens reflex (DSLR) camera was used to capture high dynamic range (HDR) images for analyzing luminance distribution within the test space, ensuring luminance levels were consistent between lighting scenes that varied in CCT but had similar illuminance levels. The location of the luminance measurement and values for each light scene is shown in Table 7.

Table 6. Illuminance Measurements Across Light Scenes in Test Room.

Lighting Condition	Desk (Task Surface) Illuminance (lx)	Eye Level Illuminance (lx)	LEGO Instruction Card Illuminance (lx)	Front Wall Illuminance (lx)	Back Wall Illuminance (lx)	Right Wall Illuminance (lx)	Left Wall Illuminance (lx)
Lighting Scene #1 (150 lx, 2700 K)	154	9	101	88	80	91	93
Lighting Scene #2 (450 lx, 2700 K)	466	27	299	265	238	273	281
Lighting Scene #3 (750 lx, 2700 K)	795	47	516	450	410	463	479
Lighting Scene #4 (150 lx, 4000 K)	148	9	97	83	77	86	89
Lighting Scene #5 (450 lx, 4000 K)	453	27	298	255	234	264	273
Lighting Scene #6 (750 lx, 6500 K)	764	45	502	429	394	443	460
Lighting Scene #7 (150 lx, 6500 K)	149	9	99	84	77	87	90
Lighting Scene #8 (450 lx, 6500 K)	461	27	304	259	238	268	278
Lighting Scene #9 (750 lx, 6500 K)	771	45	508	434	399	449	465

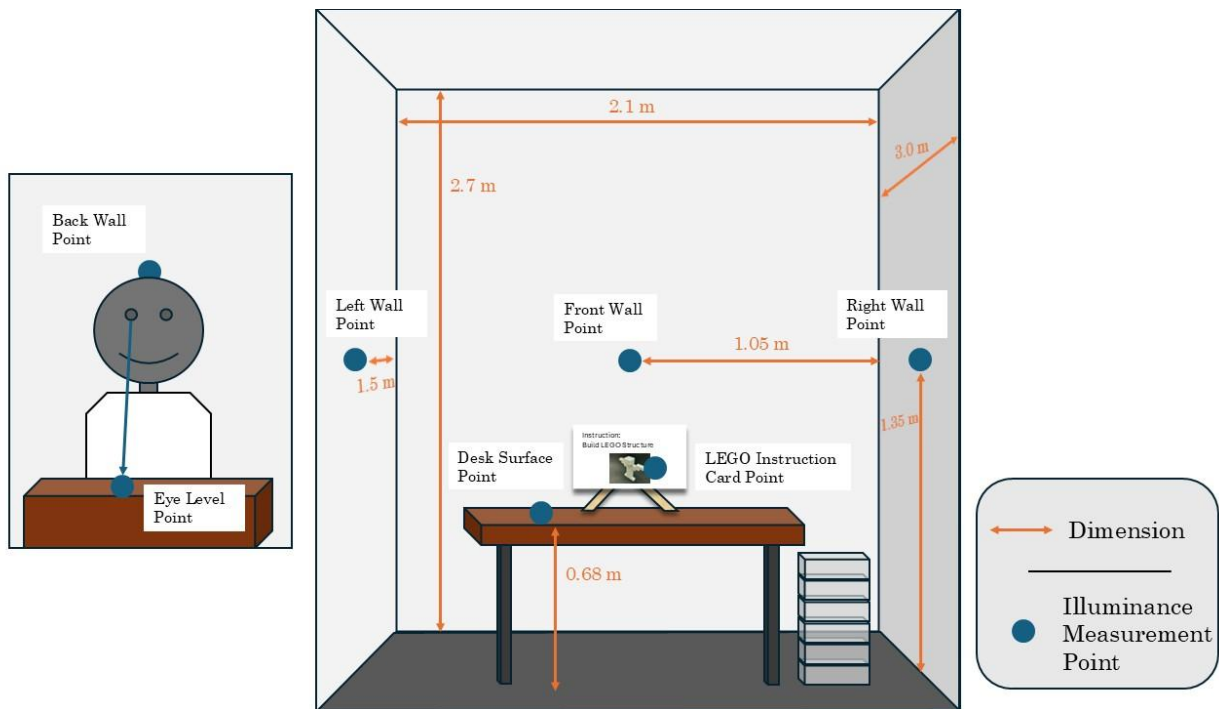
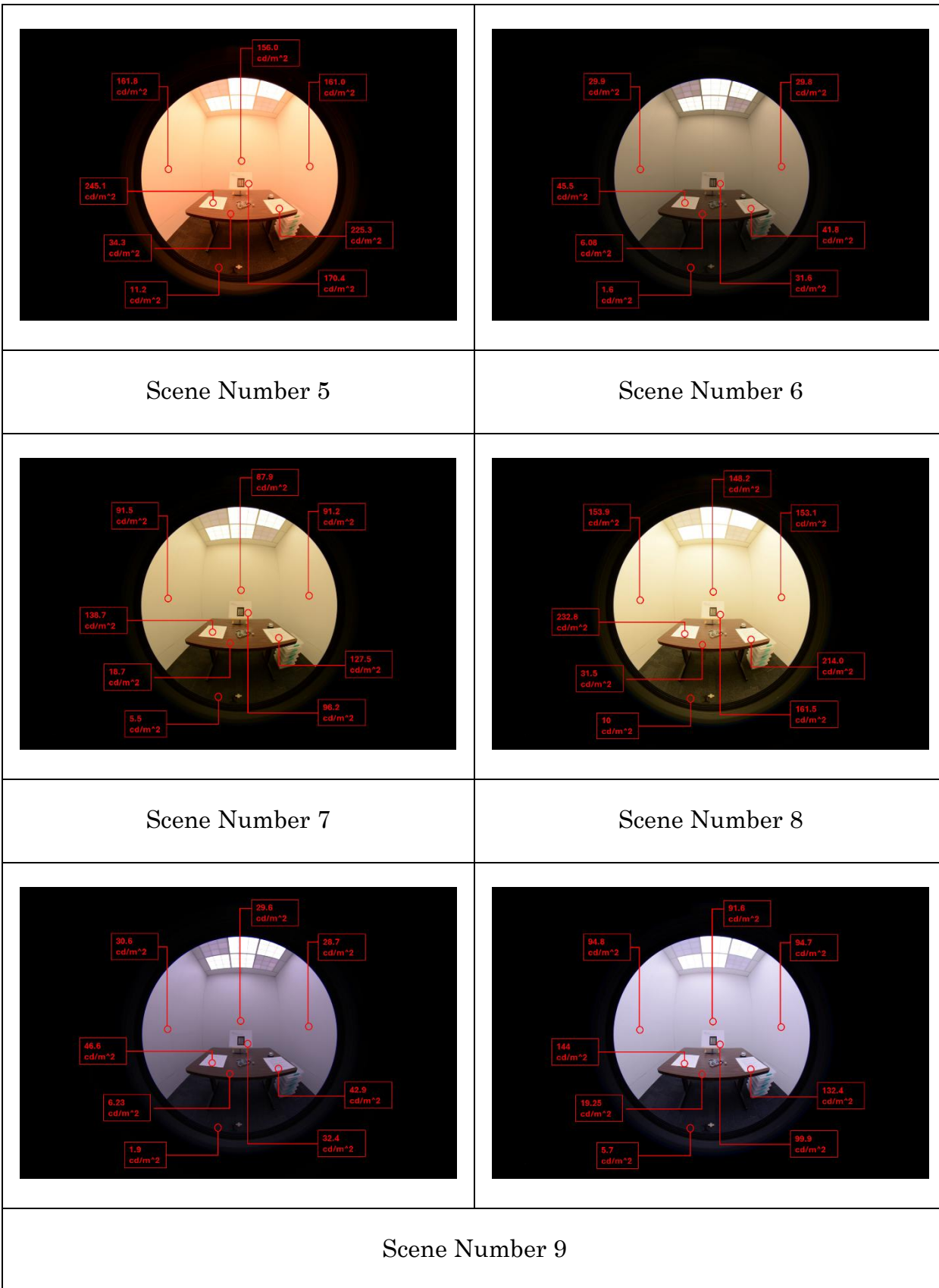
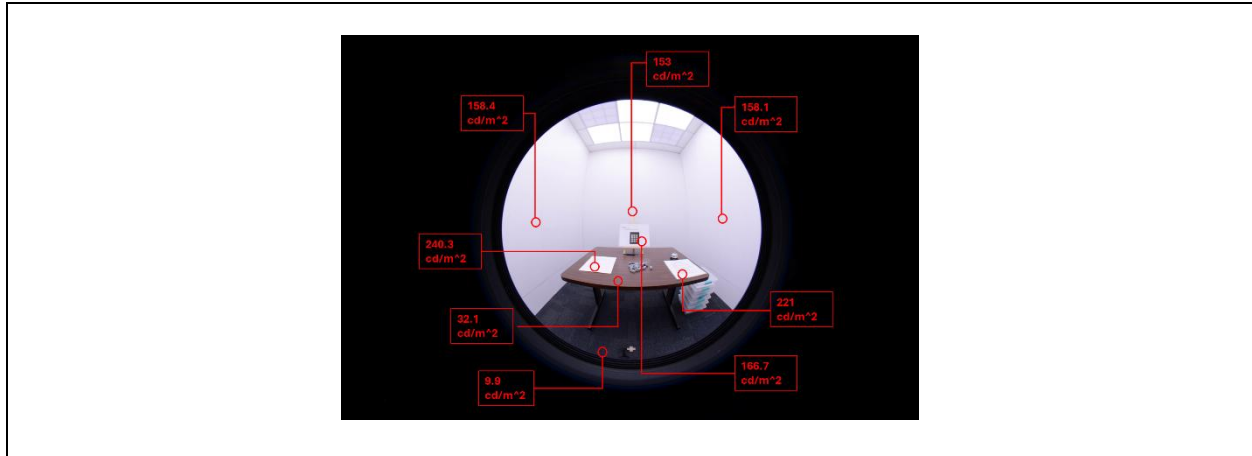

Figure 8. Location of Illuminance Measurements in the Test Room.

Table 7. Luminance Measurements Across Light Scenes in Test Room.

Scene Number 1	Scene Number 2
Scene Number 3	Scene Number 4





To assess visual performance, a standardized LEGO structure-building task was implemented. This task evaluated participants' spatial cognition, attention to detail, and task efficiency. The time taken to complete each structure was recorded using time-tracking software. In addition to objective visual performance, subjective feedback on lighting perception was gathered using a questionnaire. After exposure to each lighting condition, participants completed a Lighting Preference Questionnaire using a 7-point Likert scale. A summary of the instruments and tools used to capture data during the experiment can be seen in (Table 8). These instruments ensured precise measurement of lighting conditions, visual task performance, and subjective preferences, providing a comprehensive dataset for analyzing the relationship between lighting environments and visual performance.

Table 8. Summary of Instruments & Tools Capturing Lighting Data.

Name of tool	Purpose (i.e., what data is being collected?)
Time Tracking Software	Records the time taken to complete each structure (to document individual/cultural differences in relation visual performance)
Experiment Questionnaire (7-point Likert Scale)	Human subject evaluations of lighting preference (to document individual/cultural differences in relation to light)
Konica Minolta T-10A Illuminance Meter	Illuminance light levels within physical space at desk and eye level (to be consistent across scenes)
Digital Single-Lens Reflex (DSLR) Camera	High Dynamic Range (HDR) images of physical space to capture luminance distribution (to be consistent across scenes)
Konica Minolta LS-150 Luminance Meter	Luminance within physical space (to calibrate HDR image results)
Konica Minolta CL-500A Illuminance Spectrophotometer	Spectral power distribution of light sources in physical space (to calculate CCT at desk and eye level)

DATA ANALYSIS

The data analysis approach was divided into three sections, addressing each research question mentioned in the CURRENT STUDY. To answer the first question, the study examined the effects of various factors on LEGO build time (minutes), the dependent variable, across three cultural groups: Saudi Arabia/Kuwait, the United States (Colorado), and India/Bangladesh. Participants were recruited from each country, with the number of participants distributed among the three groups. The study incorporated several independent variables, including sleep duration, daylight exposure, gender, vision, illuminance, correlated color temperature (CCT), and cultural group (country of origin).

The data analysis process used three methods: Exhaustive CHAID classification tree analysis, ANOVA, and Spearman's Rho. CHAID, which stands for Chi-squared Automatic Interaction Detection, is a decision tree-based statistical method used to identify relationships between a categorical dependent variable and multiple independent variables. It works by repeatedly splitting the data into subgroups based on the most significant predictor, using chi-squared tests to detect interactions and differences in response patterns (Van Diepen & Franses, 2006). At each step, CHAID merges categories of predictors that behave similarly and only splits when the difference in outcomes is statistically significant, applying Bonferroni adjustments to control for multiple comparisons. The result is a tree structure where each final node (or segment) represents a unique combination of predictor values with an associated probability of the outcome. CHAID is particularly useful as it helps to uncover patterns, segment populations, and make predictions without assuming a specific data distribution. CHAID was the first step to help us identify our main predictors, so the ANOVA test was added to go into more detail with the analysis of the variables.

ANOVA, which stands for Analysis of Variance, is a statistical method used to determine if there are statistically significant differences between the averages (means) of three or more groups. It partitions the total variation in the data into between-group variation (differences due to the treatments or factors) and within-group variation (random differences or errors within the same treatment group). Then, it uses the F-test to check if the between-group differences are significantly

larger than what would be expected by chance. If a significant F-value (typically $p < 0.05$) is found, it suggests that not all group means are equal, and post-hoc tests (such as Scheffé, Tukey, or Dunnett) are used to determine which groups differ (Stahle & Wold, 1989). ANOVA is typically used to determine whether a factor, such as treatment, condition, or group, has an impact on the outcome being measured. It is commonly used in experiments to determine if different methods, environments, or populations yield significantly different results.

Spearman's Rho, often symbolized as ρ or r_s , is a nonparametric measure of correlation that assesses the strength and direction of a monotonic relationship between two variables. Unlike Pearson's correlation, which measures linear relationships using raw data, Spearman's Rho works with ranked data, making it ideal when the data is ordinal, not normally distributed, or when the relationship is not linear. It produces a value between -1 and $+1$, where $+1$ indicates a perfect increasing relationship, -1 is a perfect decreasing relationship, and 0 is no correlation (Salkind, 2007). Spearman's Rho is commonly used in the social sciences to analyze survey responses, preferences, or other ranked data. It is flexible, easy to interpret, and particularly useful when working with small samples or data that do not meet the assumptions of parametric tests.

To identify significant predictors influencing build time, an Exhaustive CHAID classification tree analysis was conducted. This method allowed for the detection of key variables that contributed to variations in performance. Additionally, a main effects ANOVA was performed to explore the effects of each

predictor and their interactions. Post-hoc Tukey tests were used to identify specific differences between groups and conditions, providing a more detailed analysis of the significant effects. The data analysis process can be found in Appendix 17.

To answer the second question, the study examined lighting scene preferences across three cultural groups where participants rated their preferences using a 7-point Likert scale, which measured their subjective evaluation of different lighting conditions. For statistical analysis, an Exhaustive CHAID classification tree analysis was conducted. This method allowed for the detection of key variables that contributed to variations in light preference. Additionally, a main effects ANOVA was conducted to examine the effects of cultural group, illuminance level, and CCT on participants' ratings of how much they preferred the lighting scene, including significant, two-way, and three-way interactions. To control for multiple comparisons, Bonferroni-adjusted post-hoc tests were used to identify significant differences between specific conditions and interactions among the variables. The data analysis process can be found in Appendix 18.

To answer the third question, the study examined the relationship between participants' preference for the light scene and build time by using Spearman's Rho as the statistical measurement tool. All statistical analyses were conducted using IBM SPSS and RStudio software. The data analysis process can be found in Appendix 19.

CHAPTER III

RESULTS

Visual Performance

An Exhaustive CHAID (classification tree) was conducted to identify significant predictors (Table 9). The classification tree identified the main variables that impact build time (in minutes), with sleep duration being the strongest predictor. Participants who slept more than seven hours had faster build times (Mean = 1.368 minutes), while participants who slept less than seven hours had slower build times (Mean = 1.601 minutes). Secondary predictors (within nodes) included the different cultural groups. Participants from the United States (Colorado) consistently had the fastest build times (Mean = 1.058 minutes). In contrast, participants from Saudi Arabia and India showed no significant difference between each other, both being slower than the U.S. group (Mean = 1.709 minutes). Additional predictors included daylight exposure and CCT, which were also secondary predictors. Participants with more daylight exposure (>25 min) and cooler light temperature (6,500 K) were associated with faster build times. The results indicate a clear interaction between sleep duration and cultural groups in predicting build time, but CCT and daylight were not as strong predictors of build time, as can be seen in the following ANOVA analysis.

Table 9. Built Time Decision-Tree Summary of Exhaust CHAID Splits.

Node	Splitting Variable	Condition	Mean Build Time (Minutes)	Interpretation
0	(Root)	All Participants	1.455	Starting point (entire dataset)
1	Sleep	≤ 7 hours	1.601	Slower build time with less sleep
2	Sleep	> 7 hours	1.368	Faster build time with more sleep
3	Group	Saudi Arabia or India	1.709	Slower build time in these groups
4	Group	Colorado, U.S.	1.058	Faster build time in this group
5	Daylight	≤ 25 min	1.352	Moderate build time
6	Daylight	> 25 min	0.972	Fastest build time
7	CCT	2,700K or 4,000K	1.043	Slightly slower than 6,500K
8	CCT	6,500K	0.781	Fastest build time within this subset

A main effects ANOVA including significant and two-way interactions was conducted to examine the effects of illuminance, CCT, gender, sleep, daylight, and cultural groups on build time (Table 10). The overall model was statistically significant, $F(9, 56) = 3.528$, $p = 0.002$, indicating that the combination of these variables explains a meaningful portion of the variation in build time. Here, the F-value (3.528) represents the ratio of explained variance to unexplained variance, and the degrees of freedom (9, 56) correspond to the number of predictors and the residuals, respectively. Since the F-value (3.528) is greater than one, the model

explains more variance than error. A p-value of 0.002 indicates that there is less than a 0.2% chance that this result occurred by random chance, making the model statistically significant. The model's adjusted R^2 of 0.259 suggests that approximately 25.9% of the variation in build time can be explained by the predictors.

Table 10. Built Time Main Effects ANOVA Results Summary. Significant Variables Highlighted in Green.

Source	df	Mean Square	F-value	Sig.
Cultural Group	2	0.521	3.591	0.034
Illuminance	2	0.375	2.362	0.104
CCT	2	0.055	0.349	0.707
Gender	1	0.023	0.147	0.703
Sleep Hours	1	0.781	4.970	0.031
Daylight Exposure	1	0.049	0.311	0.579
Cultural Group × Sleep Hours	2	0.201	1.279	0.287
Total	66	0.259	3.528	0.002

Among them, the cultural group was the most significant predictor, $F(2, 56) = 3.591$, $p = 0.034$, indicating that the variation in build time between cultures is statistically significant. U.S. participants (Mean = 1.104 minutes) built significantly faster than both Saudi (Mean = 1.455 minutes) and Indian participants (Mean = 1.598 minutes) (Figure 9). Another significant predictor was sleep duration, $F(1, 56) = 4.970$, $p = 0.031$, indicating that participants who slept more than seven hours completed the task more quickly.

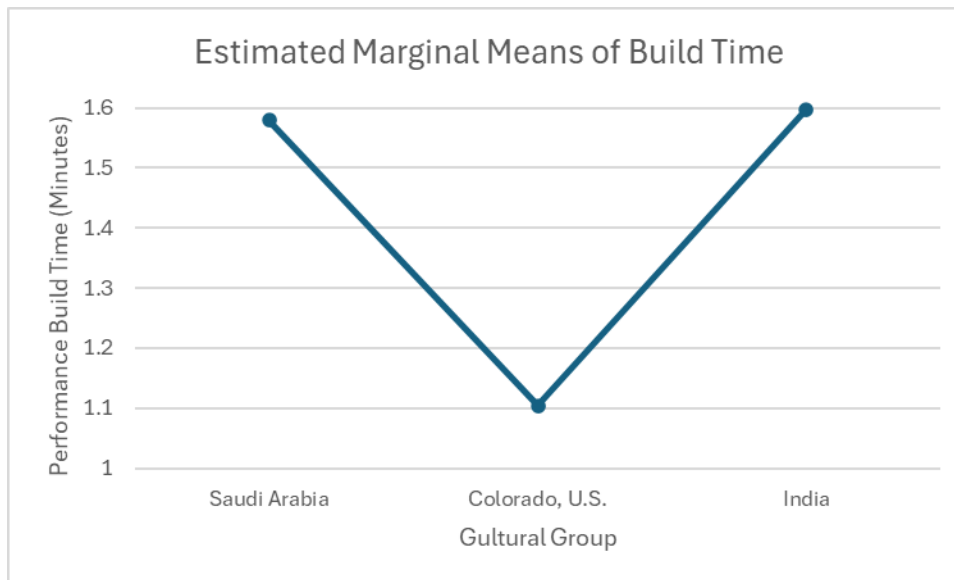

Figure 9. Differences in Built Time between Cultural Groups.

The main effects ANOVA model revealed no significant effects from illuminance, gender, daylight exposure, vision, or CCT when considered individually. A simplified two-way ANOVA was used to examine the interaction between cultural groups and sleep hours. However, it was not statistically significant ($p = 0.287$), indicating that these two variables influence build time independently rather than in combination. Lastly, a Tukey post hoc comparison confirmed that U.S. participants were significantly faster than both Saudi ($p < 0.001$) and Indian participants ($p < 0.001$). However, there was no significant difference between the Saudi and Indian groups ($p = 0.935$) (Table 11).

Table 11. Cultural Groups Post Hoc Test Results (Tukey HSD) for Built Time Comparisons.

Cultural Group (I)	Compare d Group (J)	Mean Difference (I – J)	Std. Error	Sig.	95% Confidence Interval (Lower)	95% Confidence Interval (Upper)
Saudi Arabia	United States (Colorado)	0.4509	0.11791	<0.001	0.1676	0.7343

	India	-0.0418	0.1193 3	0.935	-0.3286	0.2450
United States (Colorado)	Saudi Arabia	-0.4509	0.1179 1	<0.00 1	-0.7343	-0.1676
	India	-0.4928	0.1206 2	<0.00 1	-0.7827	-0.2029
India	Saudi Arabia	0.0418	0.1193 3	0.935	-0.2450	0.3286
	United States (Colorado)	0.4928	0.1206 2	<0.00 1	0.2029	0.7827

In summary, the results show that adequate sleep significantly enhances build performance, emphasizing its practical importance for improving efficiency. Additionally, cultural and regional differences were evident, with U.S. participants completing tasks significantly faster than those from Saudi Arabia and India. This disparity may reflect variations in familiarity with the tasks, training backgrounds, skill levels, or cultural working styles. Furthermore, daylight exposure also contributed to better performance. However, its impact was not as pronounced as that of sleep, suggesting that while natural light may provide some benefits, sleep remains the most influential factor in task efficiency. The lighting conditions, involving changes in illuminance and CCT, had no significant effect on task efficiency. The change in Cooler color temperature did show an increase in performance in the exhaust CHAID analysis, which showed some influence on built time. However, the ANOVA analysis revealed no significant difference, indicating no strong impact. Additionally, the change in illuminance levels had no impact.

Light Preference

An Exhaustive CHAID (classification tree) analysis was conducted to identify significant predictors (Appendix 20). The classification tree summary can be seen in Table 12. The classification tree identified important variables impacting light preference (on a 7-point Likert Scale), with CCT being the strongest initial predictor ($p = 0.001$). The warmer color temperature of light received high preference ratings (Mean = 4.323), while cooler light received lower ratings (Mean = 4.096). Another strong predictor was cultural differences between the different groups ($p < 0.001$). Saudi Arabia and the United States (Colorado) showed a higher liking (Mean = 5.469), while India showed a lower liking (Mean = 3.600). This indicates that Saudi Arabian and U.S. participants strongly preferred warm-colored lighting scenes, whereas Indian participants showed significantly less preference for these same warm lighting conditions. Lastly, illuminance significantly impacts the preference for participants from India under warm conditions ($p = 0.30$). For Indian participants under warmer conditions, lower illuminance (≤ 450 lx) resulted in lower liking, whereas higher illuminance (> 450 lx) significantly improved preference.

Table 12. Light Preference Decision-Tree Summary of Exhaust CHAID Splits.

Node	Split Condition	Group	Mean Preference	Interpretation
0	—	All participants	4.323	Overall moderate preference
1	CCT \leq 2700K (Warmer)	All	4.872	Warmer lighting preferred overall

2	CCT > 2700K (Cooler/Neutral)	All	4.096	Cooler lighting less preferred
3	Group = Saudi Arabia & U.S.	Warmer CCT group	5.469	Very high preference for warm lighting
4	Group = India	Warmer CCT group	3.600	Lower preference for warm lighting
5	Illuminance \leq 450 lx	Indian group under warm CCT	3.182	Low preference under low illuminance
6	Illuminance > 450 lx	Indian group under warm CCT	4.750	Improved preference under higher illuminance

A main effects ANOVA, including significant, two-way, and three-way interactions, was conducted to examine the effects of cultural group, illuminance level, and CCT on participants' ratings of how much they liked the lighting scene (Table 13). Bonferroni-adjusted post hoc tests were used to identify significant differences between specific conditions and interactions among the variables. The overall model was statistically significant ($F(26,295) = 5.173, p < 0.001$), with an effective size of approximately 25.3% (Adjusted $R^2 = 0.253$). The results revealed a significant main effect of cultural group ($F(2,295) = 5.467, p = 0.005$), indicating that cultural background had a significant influence on lighting preferences. However, the main effect of illuminance was insignificant ($F(2,295) = 0.025, p = 0.975$), suggesting that brightness alone did not strongly impact preference ratings. The main effect of CCT approached significance ($F(2,295) = 3.011, p = 0.051$), implying that color temperature may have had some influence on preference, though not at a substantial level.

Several interaction effects were significant. The interaction between culture and illuminance was highly significant ($F(4,295) = 9.51, p < 0.001$), suggesting that the effect of brightness on preference varied by cultural background. Similarly, the interaction between culture and CCT was significant ($F(4,295) = 7.724, p < 0.001$), indicating that color temperature preferences varied across cultures. The interaction between illuminance and CCT was not significant ($F(4,295) = 1.302, p = 0.269$), meaning that brightness and color temperature did not jointly affect preferences in a meaningful way. However, the three-way interaction between culture, illuminance, and CCT was significant ($F(8,295) = 2.599, p = 0.009$), suggesting that the combined influence of brightness, color temperature, and cultural background played a role in shaping participants' lighting preferences.

Table 13. Main Effects ANOVA Results for Lighting Preference Ratings by Group, Illuminance, and Color Temperature. Significant Variables Highlighted in Green.

Source	df	Mean Square	F-value	Sig.
Cultural Group	2	12.656	5.467	0.005
Illuminance	2	0.058	0.025	0.975
CCT	2	6.972	3.011	0.051
Cultural Group × Illuminance	4	22.018	9.51	<0.001
Cultural Group × CCT	4	17.884	7.724	<0.001
Illuminance × CCT	4	3.014	1.302	0.269
Cultural Group × Illuminance × CCT	8	6.018	2.559	0.009
Total	322	0.253	5.173	<0.001

From three-way interaction ANOVA, we can see differences in preference between cultural groups. Saudi Arabian participants generally showed higher preference ratings for lighting scenes compared to other cultural groups (Figure 10). They have expressed a significantly higher liking for moderate illuminance levels with cool white light (450 lx, 6,500 K, mean = 7.00). Results also show a higher preference for both warm light (2,700 K) and cool light (6,500 K) at lower illuminance levels (150 lx). At higher illuminance levels, a preference for warm light (750 lx, 2,700 K, mean = 6.50) increased, indicating that with higher illuminance, the preference shifts towards warmer color temperatures. Neutral white light was the preferred light throughout all the light scenes, with a decreasing trend as the illuminance levels increased, having the lowest rating at higher illuminance levels (750 lx, 4,000 K, mean = 2.63). The results indicate a cultural preference for moderate light levels, and cool lights followed by warm lights.

Colorado, U.S. participants demonstrated preference, with relatively stable ratings across conditions and a slight preference for lower illuminance and warmer temperatures (Figure 10). The highest ratings for all color temperatures were at the lowest illuminance, with the highest rating for warm light (150 lx, 2,700 K, mean = 5.56). The general trend indicates a decrease in preference as illuminance levels increase, with the lowest rating observed at the highest illuminance and cooler light temperature (750 lx, 6,500 K, mean = 3.11). Neutral white light stayed relatively consistent throughout the changes in illuminance levels with low preference

ratings. The results indicate a cultural preference towards lower illuminance and warmer color temperatures.

Indian participants had varied preferences, often intermediate but significantly higher liking for brighter illuminances combined with certain color temperatures (Figure 10). The highest rating for all color temperatures was at the highest illuminance level, with the highest rating for the neutral white light (750 lx, 4,000 K, mean = 6.00), followed by the cool light (750 lx, 4,000 K, mean = 5.25). The lowest ratings for preferred light scenes were at the lower illuminance levels, with the lowest rating for warm light (150 lx, 2,700 K, mean = 3.00). The results indicate a cultural preference towards higher illuminance levels and neutral to cool color temperatures.

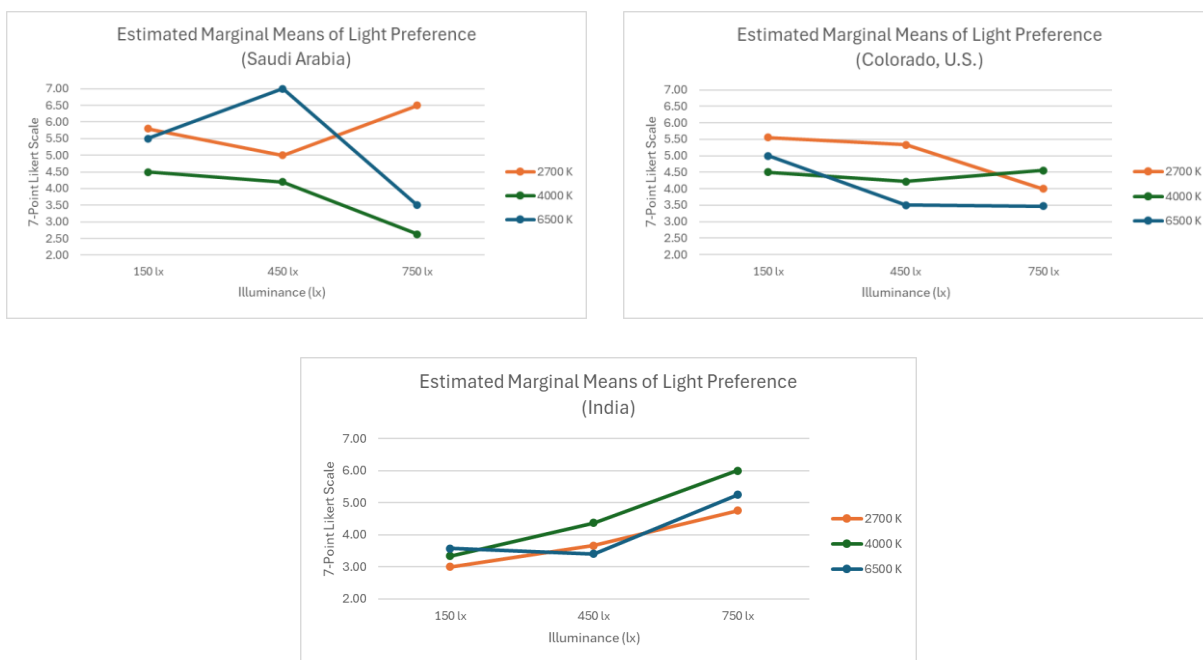

Figure 10. Estimated Marginal Means of Lighting Preference in Saudi Arabia, Colorado, U.S., and India.

In summary, the three cultural groups exhibited distinct lighting preferences (Figure 11), with Saudi Arabian participants showing the highest variability and a

strong preference for moderate illuminance (450 lx) with cooler temperatures (6,500 K), as well as warm light at low and high illuminance (150 lx & 750 lx, 2,700 K). In contrast, American participants displayed relatively stable preferences, favoring lower illuminance (150 lx) with warm light (2,700 K) and showing a general decline in preference as illuminance increased, particularly for cooler light (750 lx, 6,500 K). Indian participants, on the other hand, preferred higher illuminance levels (750 lx) overall, with the highest rating for neutral white light (4,000 K) and a trend toward cooler temperatures at brighter settings. A key similarity across all groups was the dislike for neutral white light (4,000 K) at higher illuminance levels, particularly for Saudi Arabian and American participants. Additionally, preference trends fluctuated more sharply for Saudi Arabian and Indian participants, whereas American ratings were more consistent, reinforcing a cultural tendency toward stability in lighting preferences. These results highlight the importance of designing adaptable lighting environments that accommodate cultural variability in brightness and color temperature preferences.

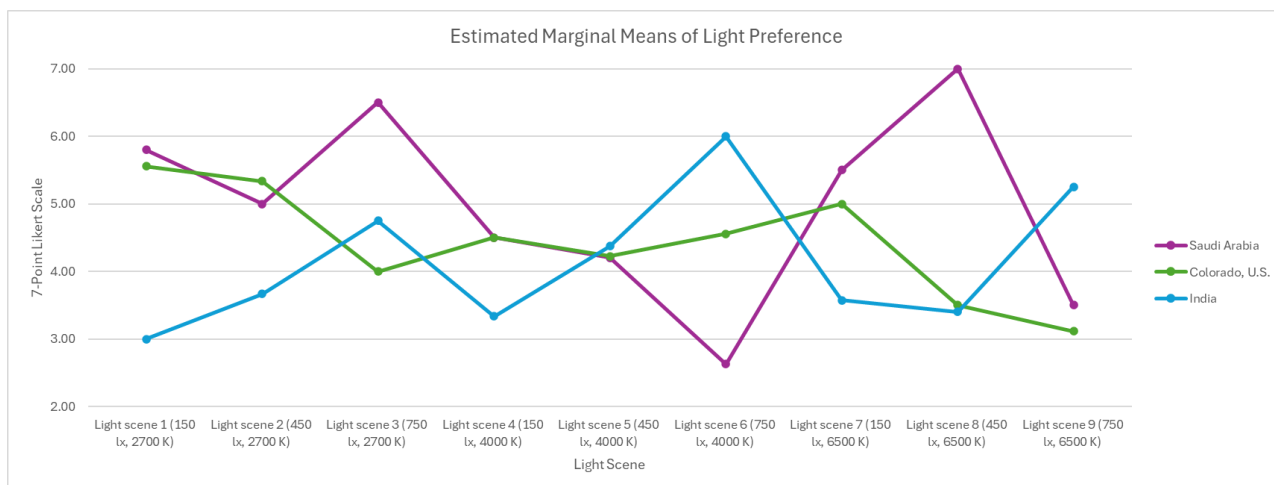

Figure 11. Estimated Marginal Means of Lighting Preference Across Cultural Groups, Illuminance Levels, and CCT.

Visual Performance & Light Preference Correlation

To examine the relationship between participants' preference for the light scene and build time, Spearman's Rho was used as a statistical measurement tool. The Spearman's correlation coefficient ($\rho = 0.027$) indicates a very weak, positive correlation between these two variables (Table 14). This suggests that there is almost no meaningful relationship between the extent to which participants liked the lighting scene and the time they took to complete the task. Additionally, the correlation was not statistically significant ($p = 0.628$, $N = 27$), meaning that preference for the lighting scene had no measurable effect on build performance.

From a practical standpoint, these results suggest that participants' preference for lighting conditions did not impact their task performance. Regardless of whether individuals strongly liked or disliked the lighting environment, their build times remained unaffected. This suggests that other factors, such as skill level, sleep duration, or cultural background, may play a more significant role in determining build speed than personal lighting preference alone.

Table 14. Spearman's Correlation Results Between Lighting Preference and Build Time.

Spearman's Rho Analysis Results	
Spearman's rho	0.027
Significance (p-value)	0.628
Sample Size	27

DISCUSSION

This study aimed to investigate how cultural background influences lighting preferences and visual performance in an office-like environment with varying light intensities and apparent color temperatures. The results demonstrated that

cultural background, along with contextual factors such as sleep duration, had a significant impact on participants' visual task efficiency. At the same time, neither light intensity nor apparent color alone had a significant influence on performance. However, changes in light intensity and color temperature did have a significant effect on lighting preferences across cultures. A notable finding was the lack of correlation between preference and performance, suggesting that these two variables may operate independently in short cognitive tasks.

Visual performance analysis showed that cultural background had a measurable effect on task efficiency. Participants from the United States (Colorado), consistently completed the cognitive task (LEGO model-building) faster than participants from Saudi Arabia and India. This performance gap may reflect cultural distinctions in familiarity with task types, educational background, or exposure to similar problem-solving activities. Interestingly, while correlated color temperature (CCT) appeared to be associated with faster build times under cooler light (6,500 K) in the Exhaustive CHAID analysis, the ANOVA results showed no significant effect. This indicates that neither CCT nor illuminance levels had a statistically meaningful impact on performance. These findings contradict previous literature suggesting that cooler CCT and higher illuminance enhance cognitive performance; however, the discrepancy may be attributed to the short task duration, which may not have allowed sufficient time for participants to adapt to the lighting conditions. A longer or more demanding task might be necessary to observe differences.

Additionally, non-cultural factors, such as sleep duration, emerged as strong predictors of performance. Participants who reported more than seven hours of sleep completed the task faster, supporting previous findings by Belenky et al. (2003) that link sleep deprivation to performance degradation. Daylight exposure also appeared to influence task efficiency in the CHAID analysis, as participants exposed to greater amounts of daylight performed better. However, the ANOVA analysis did not show significance in build-time for this variable, suggesting that while daylight exposure may contribute, it is not a strong standalone predictor of performance. These results highlight the multifaceted nature of visual performance, where cultural background interacts with lifestyle and physiological factors to influence cognitive outcomes.

The analysis of lighting preferences revealed clear cultural differences in how participants evaluated various lighting scenes. Participants from Saudi Arabia and the United States generally preferred warm light (2,700 K), particularly at lower illuminance levels (150 lx–450 lx), whereas participants from India favored neutral to cool white light (4,000 K–6,500 K) at higher illuminance levels (750 lx). These findings align with previous literature linking lighting preferences to long-term adaptation to environmental conditions, architectural lighting traditions, and cultural norms (Madan, 2023; Park et al., 2010).

For example, Saudi participants' strong preference for cool light at 450 lx may reflect adaptation to the region's bright, sunny climate, while their preference for warm light may be influenced by religious spaces that traditionally use warmer

lighting. Similarly, in the U.S., seasonal daylight availability and the prevalence of energy-efficient, low-CCT lighting standards may explain the preference for warmer and dimmer lighting.

In contrast, Indian participants showed a stronger preference for brighter, cooler lighting, which may reflect acclimation to high ambient light environments and cultural associations of brightness with productivity and alertness, particularly in workspaces that integrate daylighting (Pathak et al., 2015).

Another possible explanation for these differences is the influence of common residential lighting practices, which are often shaped by the dominant lighting products available in regional markets. Over time, exposure to specific illuminance levels and CCT ranges may condition individuals to prefer what they are most frequently exposed to in daily life.

A comparison of latitude also revealed potential patterns. U.S. participants appeared to show different preferences than Indian participants, which may suggest an effect of latitude-related daylight exposure. However, the similarity in preferences between Saudi Arabian and U.S. participants, both favoring warm light, suggests that latitude is not the sole determinant. Instead, cultural influences such as religion, tradition, and lighting conventions likely also play an important role.

Additionally, a significant three-way interaction between culture, illuminance, and CCT indicates that lighting preferences are not driven by

individual variables in isolation. Instead, they emerge from the interplay between light intensity, spectrum, and cultural background.

Notably, the study found no meaningful correlation between participants' preference ratings and their task performance. The Spearman's Rho test indicated a very weak and non-significant relationship, suggesting that participants did not necessarily perform better under the lighting conditions they preferred. This challenges the common assumption that lighting environments perceived as more comfortable or pleasant inherently improve cognitive performance. One explanation for this disconnect is that participants may have based their preferences on emotional or visual comfort rather than on how the lighting affected their task performance. This is particularly plausible in short, focused tasks such as LEGO building, where lighting might influence mood or perception but not performance within a limited time frame. Moreover, participants may not have been consciously aware of how lighting conditions were affecting their performance in real-time. This disconnect underscores the complexity of lighting design. While occupant satisfaction is important, it may not always translate to measurable gains in task efficiency. Future studies should investigate whether this disconnect persists in more prolonged or cognitively demanding tasks, or if the relationship between lighting preference and performance varies across different workplace settings.

Other factors may have influenced the results of this study but were not fully captured in the analysis. One such factor is the participant's mood during the experiment. Initially, a PANAS-SF mood model was included to assess participants'

mood on the day of the experiment, using a one-day log, to examine whether mood might influence performance. However, this measure was later excluded from the analysis because we did not capture mood during each lighting condition in the experiment, which was critical for meaningful comparison. Previous research has shown that mood responses to lighting vary across individuals and cultural groups, with different lighting scenes eliciting different emotional reactions (Küller et al., 2006). Given that each task in this study lasted less than five minutes, participants may not have had sufficient time to emotionally adapt to each lighting scene. As a result, it is difficult to assess whether lighting had any measurable impact on mood.

Another important factor is the Color Rendering Index (CRI), which influences how accurately colors appear under different lighting conditions. A higher CRI may enhance visual clarity and aesthetic quality, potentially increasing the preference for lighting. Another consideration is flicker, especially in LED lighting systems. Even if not consciously perceived, temporal light modulation (TLM) can contribute to visual discomfort, eye strain, and reduced task efficiency. Minor inconsistencies in TLM between scenes could have affected participants' subjective experiences and visual performance.

A final important consideration is the distinction between correlated color CCT and SPD. While this study varied CCT across lighting scenes, it is possible that the changes in spectral content were not fully aligned or equally distributed across scenes. This matters because CCT is a simplified descriptor of a light source's color appearance, while SPD provides a more detailed representation of wavelength

composition, which can have stronger physiological and perceptual effects. Cultural differences in visual performance may be more closely related to specific wavelengths, such as variations in short-wavelength (blue/violet) or long-wavelength (orange/red) light, than to generalized CCT labels. Adjusting or analyzing specific spectral regions with greater precision could reveal stronger associations between light composition and performance, particularly across cultural groups.

It is essential to understand how different cultures can adapt to varying light conditions in the work environment. Differences were found in build time between the cultural groups, as well as in light preference. Although no correlation was found between preference and performance in terms of task efficiency and performance in short cognitive tasks, a correlation may exist for longer, more challenging tasks. There is a need to understand how differences in illuminance and color temperature (CCT) across various cultures can contribute to creating a more inclusive and productive work environment.

LIMITATIONS

This study was conducted in a controlled laboratory setting rather than a real-world office environment. While this approach ensured that all participants experienced the same standardized conditions, it may have influenced participants' responses. The physical environment can significantly impact an individual's perception of space, influencing their mood, preferences, and task performance. Collecting data from culturally diverse workers in an actual office setting could

provide a more comprehensive understanding of how different lighting conditions impact visual preference and performance.

The participant sample was primarily recruited from the student body and was limited to individuals residing in Colorado, USA, which may limit the generalizability of the findings. Additionally, recruitment posed challenges, as the study required participants from specific cultural backgrounds. This resulted in a lower participant count than expected, which may have impacted the reliability of the results. To increase sample representation, participants from Kuwait and Bangladesh were included in the Saudi Arabian and Indian cultural groups, respectively. While this adjustment aimed to improve participant distribution, it may have influenced the findings.

Due to concerns about participant engagement and experiment duration, the number of lighting scenes was reduced from nine to six. As a result, participants did not experience all lighting conditions, and some were exposed to different lighting scenes than others. To maintain consistency, certain lighting scenes were kept constant for all participants, while the remaining scenes were randomized.

The experiment utilized a LEGO model-building task as a performance metric. However, this task may not fully capture workplace-related performance. Additionally, the duration of each task was limited to five minutes per lighting scene, which may not have allowed participants sufficient time to fully adapt to the lighting conditions. Adaptation times can vary between individuals, and this limitation may have led to carryover effects between lighting scenes. The short task

duration also restricted the ability to measure mood fluctuations during the experiment.

FUTURE WORK

While this study offers valuable insights into the impact of cultural background on lighting preferences and visual performance, there are several opportunities for future research to build upon and expand these findings. One key area is the application of this research in real-world office environments. Although the controlled laboratory setup ensured consistency across participants, it does not fully capture the complexity of actual work settings where factors such as ambient noise, personal lighting setups, and workplace dynamics could influence both preference and performance. Replicating the study in naturalistic settings would enhance the validity. If this study is conducted in a real-world office environment, measuring luminance becomes crucial, as light reflects differently off different materials, which affects the perception of the visual environment.

Furthermore, future research should aim to expand the participant pool beyond the university student population. Including individuals of varying ages, occupations, and cultural backgrounds would allow for more generalizable conclusions. Extending the cultural scope to include participants from other regions could also offer a more global perspective on lighting preferences and needs. Furthermore, the LEGO-building task, while effective for assessing spatial and visual performance, represents only a narrow range of cognitive work. Future studies could incorporate a variety of task types, such as reading comprehension,

decision-making, and creative problem-solving, to better reflect the diversity of real-world work activities. Additionally, future work could include more color tasks and measurements of CRI and SPD to better understand how different cultures might interact with the apparent color of the visual environment. The study found that different cultures had different efficiencies in the build task, not related to the light conditions. Future studies can look into what other cultural factors, such as familiarity with task types, educational background, or exposure to similar problem-solving activities, might influence these differences.

Longer duration studies are also recommended to explore the effects of prolonged exposure and adaptation to different lighting conditions. Short-term responses may differ significantly from long-term comfort or performance outcomes, especially as individuals acclimate to their environments over time. By conducting a more extended study, the inclusion of subjective light perception of brightness and dimness can help in better understanding mood within each light scene, rather than relying solely on lighting measurements (illuminance levels and CCT). This could help further our understanding of self-reported preferences for light by measuring mood and perception of light across different cultures. Additionally, physiological and behavioral data, such as eye strain related to TLM, heart rate variability, or melatonin levels, could further elucidate the biological mechanisms underlying lighting responses and provide a more objective foundation for interpreting self-reported preferences. For example, measuring eye strain through blink rate or visual fatigue questionnaires can help determine if lighting conditions are

contributing to discomfort even when participants report high satisfaction. Heart rate variability (HRV) can provide insight into stress or relaxation levels under various lighting conditions, serving as an indirect marker of cognitive load and emotional state. Similarly, monitoring melatonin levels through either salivary samples or wearable biosensors can reveal how various lighting conditions influence circadian regulation and alertness, especially under cooler, high-CCT lighting conditions. Integrating these physiological indicators with behavioral performance metrics and subjective feedback would enable a more comprehensive understanding of how lighting affects humans at both conscious and subconscious levels. Finally, exploring user-controlled lighting systems such as tunable LEDs would offer insight into how control and personalization affect comfort and productivity. Investigating dynamic lighting environments that respond to user behavior or circadian rhythms may help develop more inclusive and adaptable lighting strategies tailored to diverse cultural and individual needs.

IMPLICATIONS

The findings of this study carry several important implications for lighting design in diverse and multicultural work environments. As workplaces become increasingly globalized, understanding how individuals from different cultural backgrounds perceive and perform under varying lighting conditions is essential for creating inclusive and effective environments. The results suggest that cultural background has a significant influence on lighting preference, and although it may not directly correlate with performance outcomes in short tasks, it still plays a

crucial role in occupant satisfaction and psychological comfort. Although This highlights importance of designing lighting systems that go beyond standardized recommendations and consider the subjective experiences and expectations shaped by regional, environmental, and cultural factors.

Moreover, the variability in preferences observed across cultural groups emphasizes the need for flexibility in lighting design. Fixed, one-size-fits-all lighting strategies may not adequately address the diverse needs of a global workforce. Instead, adaptive lighting systems, such as tunable LEDs with user-controlled settings, can empower individuals to tailor their lighting environments to better suit their comfort and productivity. Such systems not only enhance user satisfaction but may also support well-being, reduce eye strain, and improve long-term workplace engagement. Integrating these insights into design standards, certification systems (like WELL and LEED), and workplace policies could lead to environments that are both more inclusive and more effective.

It is essential to recognize that the use of IES standards is a suitable starting point for establishing general performance lighting specifications in a workplace environment, as the study concluded that there was no strong effect of light intensities and apparent color on individual performances of short tasks, and no correlation was found between preference and performance.

On a broader level, this research supports the growing movement toward human-centric lighting design, where occupant experience is prioritized alongside energy efficiency and architectural integration. By recognizing that lighting is not

just a technical specification but a sensory and cultural experience, designers and engineers can develop environments that support a wider range of human needs physiological, psychological, and emotional. As organizations strive to create inclusive, healthy, and productive workspaces, aligning lighting strategies with the diverse experiences of their occupants will become an increasingly valuable and necessary component of design practice.

REFERENCES

- Aryani, S. M., Kusumawanto, A., & Suryabrata, J. A. (2020). Lighting in the Workplace as the Visual Environment That Affects the Occupant's Mood: A Literature Review: Proceedings of the 3rd International Conference on Dwelling Form (IDWELL 2020). 3rd International Conference on Dwelling Form (IDWELL 2020), Sanur, Bali, Indonesia. <https://doi.org/10.2991/assehr.k.201009.002>
- Baron, R. A., Rea, M. S., & Daniels, S. G. (1992). Effects of indoor lighting (illuminance and spectral distribution) on the performance of cognitive tasks and interpersonal behaviors: The potential mediating role of positive affect. *Motivation and Emotion*, 16(1), 1–33. <https://doi.org/10.1007/BF00996485>
- Belenky, G., Wesensten, N. J., Thorne, D. R., Thomas, M. L., Sing, H. C., Redmond, D. P., Russo, M. B., & Balkin, T. J. (2003). Patterns of performance degradation and restoration during sleep restriction and subsequent recovery: A sleep dose-response study. *Journal of Sleep Research*, 12(1), 1–12. <https://doi.org/10.1046/j.1365-2869.2003.00337.x>
- Bishop, D., & Chase, J. G. (2023). A Luminance-Based Lighting Design Method: A Framework for Lighting Design and Review of Luminance Measures. *Sustainability*, 15(5), 4369. <https://doi.org/10.3390/su15054369>
- Bornstein M. H. (1973). Color vision and color naming: a psychophysiological hypothesis of cultural difference. *Psychological bulletin*, 80(4), 257–285. <https://doi.org/10.1037/h0034837>
- DiLaura, D. L., Houser, K. W., Mistrick, R. G., & Steffy, G. R. (2011). *The Lighting Handbook: Reference and Application* (10th ed.). Illuminating Engineering Society.
- DMX White Paper. Current Lighting. (2022). https://cdn.currentlighting.com/site/specsheet/KL_DMX_whitepaper_spec.pdf
- Eissa, H. (2020). THE IMPACT OF VISUAL ENVIRONMENT ON ILLUMINANCE LEVELS PREFERENCES CROSS-CULTURE CASE STUDY ON OMANI AND PORTUGUESE FORTS IN OMAN. *Architecture and Planning Journal (APJ)*, 23(1). <https://doi.org/10.54729/2789-8547.1045>
- Goodman, T. (2006). Better Lighting for Improved Human Performance, Health and Well-Being, and Increased Energy Efficiency—A Scoping Study for CIE-UK.
- Gordon, G. (2003). *Interior lighting for designers* (4th ed.). Wiley. <https://doi.org/10.1080/15502724.2020.1808014>

Hansen, E. K., Pajuste, M., & Xylakis, E. (2022). Flow of Light: Balancing Directionality and CCT in the Office Environment. *LEUKOS*, 18(1), 30–51. <https://doi.org/10.1080/15502724.2020.1808014>

Illuminating Engineering Society. (2020). Lighting offices spaces: Recommended practice RP-1-20. Illuminating Engineering Society.

International Well Building Institute. International WELL Building Institute. (2024). <https://www.wellcertified.com/>

Karlen, M. & Spangler, C. (2023) *Lighting Design Basics*. 4th edn. Wiley.

Küller, R., Ballal, S., Laike, T., Mikellides, B., & Tonello, G. (2006). The impact of light and colour on psychological mood: A cross-cultural study of indoor work environments. *Ergonomics*, 49(14), 1496–1507. <https://doi.org/10.1080/00140130600858142>

Kwallek, N., Lewis, C. M., Lin-Hsiao, J. W. D., & Woodson, H. (1996). Effects of nine monochromatic office interior colors on clerical tasks and worker mood. *Color Research & Application*, 21(6), 448–458. [https://doi.org/10.1002/\(SICI\)1520-6378\(199612\)21:6<448::AID-COL7>3.0.CO;2-W](https://doi.org/10.1002/(SICI)1520-6378(199612)21:6<448::AID-COL7>3.0.CO;2-W)

LEED rating system. LEED rating system | U.S. Green Building Council. (n.d.). <https://www.usgbc.org/leed>

Luxeon Rebel Color Line. Lumileds. (2024). <https://otmm.lumileds.com/adaptivemedia/73c0bbb3dad3f9c1782bdc33f0d654e8ce3a507e>

Madan, I. (n.d.). *Light Cultivates Culture, Culture Cultivates Light*.

Najjar, G. A., Akkad, K., & Almahdaly, A. H. (2023). Classification of Lighting Design Aspects in Relation to Employees' Productivity in Saudi Arabia. *Sustainability*, 15(4), 3614. <https://doi.org/10.3390/su15043614>

National Academy of Sciences of Ukraine / V.E. Lashkaryov Institute of Semiconductor Physics, Kyiv, Ukraine, Rybalochka, A., Kornaga, V., Kalustova, D., Mukhin, V., Kornaga, Y., Zavgorodnii, V., & Valyukh, S. (2022). White Colour Hues in Displays and Lighting Systems Based on RGB and RGBW LEDs. *International Journal of Image, Graphics and Signal Processing*, 14(3), 1–10. <https://doi.org/10.5815/ijigsp.2022.03.01>

Park, N., & Farr, C. A. (2007). The Effects of Lighting on Consumers' Emotions and Behavioral Intentions in a Retail Environment: A Cross-Cultural Comparison.

Journal of Interior Design, 33(1), 17–32. <https://doi.org/10.1111/j.1939-1668.2007.tb00419.x>

Park, N., Pae, J. Y., & Meneely, J. (2010). Cultural Preferences in Hotel Guestroom Lighting Design. *Journal of Interior Design*, 36(1), 21–34. <https://doi.org/10.1111/j.1939-1668.2010.01046.x>

Pathak, P. M., & Dongre, A. (2015). LIGHTING DESIGN AS A FUNCTION OF USER COMFORT AND PERFORMANCE IN INDIAN WORK SPACES. *Journal of Architectural and Planning Research*, Vol. 32, No. 2 (Summer, 2015), pp. 168-179. <https://www.jstor.org/stable/44113106>

Raggiunto, S., Belli, A., Palma, L., Ceregioli, P., Gattari, M., & Pierleoni, P. (2019). An Efficient Method for LED Light Sources Characterization. *Electronics*, 8(10), 1089. <https://doi.org/10.3390/electronics8101089>

Rea, M. S. (2000). *The IESNA lighting handbook: Reference & application*. Illuminating Engineering Society of North America.

Recommended practice: Lighting office spaces: An American National Standard. (2022). Illuminating Engineering Society.

Salkind, N. J. (2007). Spearman's Rho. *Encyclopedia of Measurement and Statistics*. <https://doi.org/10.4135/9781412952644.n424>

Shlayan, N., Venkat, R., Ginobbi, P., & Mercier, G. (2008). A Novel RGBW Pixel for LED Displays. 2008 19th International Conference on Systems Engineering, 407–411. <https://doi.org/10.1109/ICSEng.2008.43>

Stahle, L., & Wold, S. (1989). Analysis of variance (ANOVA). *Chemometrics and Intelligent Laboratory Systems*, 6(4), 259–272. [https://doi.org/10.1016/0169-7439\(89\)80095-4](https://doi.org/10.1016/0169-7439(89)80095-4)

The Basics of a DMX System. Pharos Controls. (2022). <https://www.pharoscontrols.com/>

Van Diepen, M., & Franses, P. H. (2006). Evaluating chi-squared automatic interaction detection. *Information Systems*, 31(8), 814–831. <https://doi.org/10.1016/j.is.2005.03.002>

Veitch, J., Newsham, G., Boyce, P., & Jones, C. (2008). Lighting appraisal, well-being and performance in open-plan offices: A linked mechanisms approach. *Lighting Research & Technology*, 40(2), 133–151. <https://doi.org/10.1177/1477153507086279>

Watson, D., Anna, L., & Tellegen, A. (n.d.). Development and Validation of Brief Measures of Positive and Negative Affect: The PANAS Scales. <https://doi.org/10.1037/0022-3514.54.6.1063>

Weinhouse, G. L., & Devlin, J. W. (Eds.). (2022). *Sleep in Critical Illness: Physiology, Assessment, and Its Importance to ICU Care*. Springer International Publishing. <https://doi.org/10.1007/978-3-031-06447-0>

Wilkins, A., Veitch, J., & Lehman, B. (2010). LED lighting flicker and potential health concerns: IEEE standard PAR1789 update. 2010 IEEE Energy Conversion Congress and Exposition, 171–178. <https://doi.org/10.1109/ECCE.2010.5618050>

Yi, Y.-S., & Ha, M.-K. (2013). A Study on the Lighting Plan Characteristics of Office Buildings. *Korean Institute of Interior Design Journal*, 22(1), 47–54. <https://doi.org/10.14774/JKIID.2013.22.1.047>

APPENDIX

Appendix 1. Terminologies of Key Lighting Concepts.

Lighting an office work environment requires consideration of several key characteristics, including illuminance, luminance, correlated color temperature (CCT), color rendering index (CRI), and flicker (Kirsch, 2014; Yi & Ha, 2013). These factors influence visual comfort, task performance, and overall occupant well-being.

Illuminance is one of the most referenced lighting parameters in guidelines and specifications; it refers to the amount of light falling on a surface and is measured in lux (lx) (ANSI/IES RP-10-20, 2022). Recommended illuminance for task visibility is typically measured at the task surface, commonly referred to as the desk surface, which is generally positioned 0.75 m (30 in.) above the floor. The ANSI/IES RP-10-20 handbook offers maintained localized and area illuminance recommendations for a wide range of office tasks, recommending an illuminance range of 300 lx to 500 lx for cognitive tasks such as reading and writing.

While traditional lighting design relies heavily on illuminance, it does not fully capture essential visual parameters such as contrast, brightness perception, and glare, all of which directly impact human vision and comfort (Bishop & Chase, 2023). Luminance, measured in Candelas per square meter (cd/m^2), represents the amount of light reflected or emitted from an area (ANSI/IES RP-10-20, 2022). Although illuminance quantifies the amount of light falling on a surface, luminance determines how light is distributed within a space, taking into consideration the surfaces, ultimately affecting visual effectiveness.

This distinction is crucial because two spaces with identical illuminance levels can yield vastly different visual experiences depending on luminance distribution and surface reflectance. Higher luminance in specific areas can enhance task performance, whereas excessive luminance contrasts may induce glare and discomfort (Bishop & Chase, 2023). Additionally, brightness perception is influenced not just by illuminance but also by spatial light distribution, reflections, and surrounding contrast (Rea, 2000).

CCT and CRI are crucial for accurately rendering the true quality of colors and materials within a space, thereby assisting designers in selecting the optimal lighting (Karlen & Spangler, 2023). CCT, measured in Kelvin (K), determines whether a light source appears warm, neutral, or cool white (Gordon, 2003). The spectral composition of light influences object perception, making it essential to choose an appropriate CCT for specific applications. Warm white light at 3,000 K or lower emits an orange-yellow hue, creating a cozy and relaxed atmosphere. Neutral white light, with a temperature of around 4,000 K, appears more balanced and natural. Cool white light at 5,000 K or higher has a blue-white tone, which is often associated with alertness and productivity (Park & Farr, 2007).

Although the IES Handbook does not specify a required CCT for office environments, industry practices suggest that office lighting typically falls within the middle-of-the-road approach of 3,000K to 3,500 K or reaching up to 4,500 K for increased alertness effect (DiLaura, D. L., Houser, K. W., Mistrick, R. G., & Steffy,

G. R., 2011). Generally, higher CCT values contribute to a more stimulating and active work environment, while lower CCT values promote relaxation.

CCT is derived from the Spectral Power Distribution (SPD), which describes how optical power is distributed across different wavelengths in the visible spectrum. SPD is typically represented as a graph, with wavelengths (380 nm–780 nm) on the x-axis and relative power intensity on the y-axis. Each section of the visible spectrum corresponds to specific perceived color ranges, as shown in Figure 12. The combination of radiant power at these wavelengths determines a light source’s perceived color temperature. A source with higher intensity in the red spectrum will appear warmer, such as 2,700 K–3,000 K, while a source with stronger emission in the blue spectrum will appear cooler, such as 5,000 K–6,500 K.

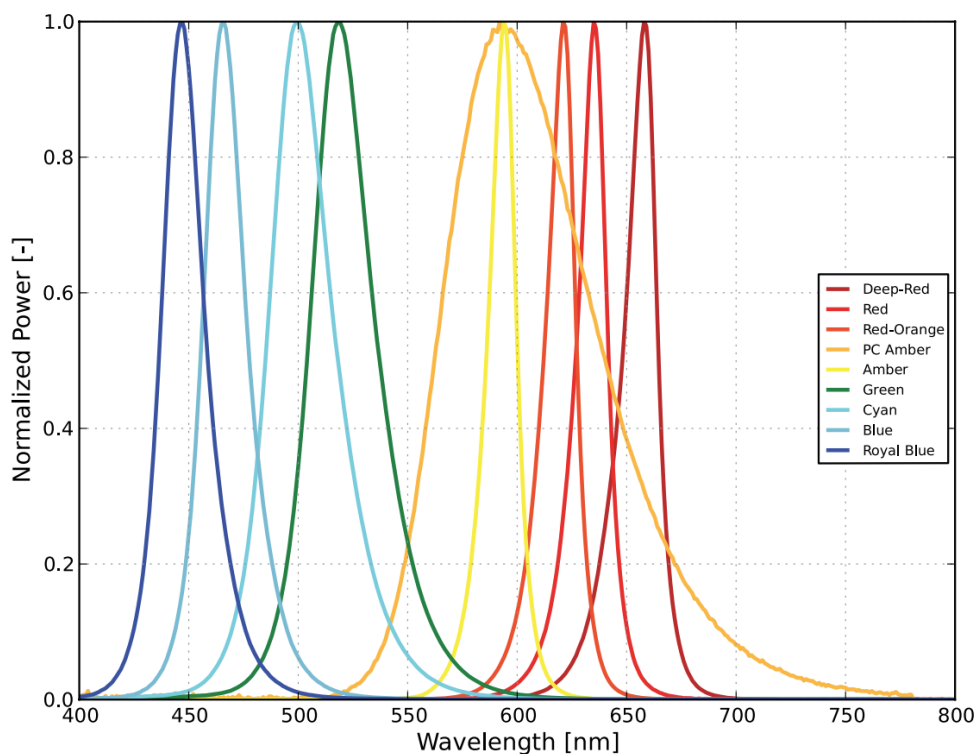

Figure 12. Spectral Power Distribution (SPD) with Common LED Colors within the Visible Spectrum. Retrieved from Luxeon Rebel Color Line. Lumileds. (2024).

CRI, measured on a scale from 0 to 100, evaluates how accurately a light source reproduces colors compared to a reference source of the same CCT, such as incandescent light or daylight (Rea, 2000; Karlen & Spangler, 2023). A CRI of 100 represents perfect color accuracy. The IES Handbook recommends a CRI of at least 80, with a CRI of 90 or greater preferred for environments where color discrimination is crucial (ANSI/IES RP-10-20, 2022).

Flicker refers to rapid fluctuations in light intensity over time, typically caused by variations in electrical current supplied to the light source. Flicker is classified into two categories: visible flicker, occurring at or below 70 Hz, and invisible flicker, which exceeds 70 Hz and is not consciously perceived but can still affect neurological responses (Wilkins et al., 2010).

In LED lighting, flicker often results from pulse-width modulation (PWM) dimming, power fluctuations, or the design of the driver circuit. Both visible and invisible flicker can negatively impact visual performance, eye strain, and neurological comfort if not adequately controlled. A flicker threshold of at least 120 Hz is generally recommended to prevent discomfort in office spaces (ANSI/IES RP-10-20, 2022).

LED lighting has become the predominant choice for office environments due to its energy efficiency, long lifespan, high-quality light, and advanced digital control capabilities (Raggiunto et al., 2019). Compared to incandescent and fluorescent lamps, LED fixtures consume significantly less power, resulting in reduced maintenance and energy costs.

Additionally, LED dimming plays a crucial role in adjusting both CCT and spectral output, particularly in adaptive lighting systems. One method for achieving precise spectral tuning is the use of RGBW LED systems, which incorporate a dedicated white LED alongside red, green, and blue LEDs. Unlike traditional mixed-color dimming, RGBW configurations enhance spectral stability, enabling more efficient white light production while maintaining color uniformity and consistency across various dimming levels (Shlayan et al., 2008; Rybalochka et al., 2022).

This capability is particularly valuable in architectural lighting applications, where maintaining stable and high-quality illumination is crucial for visual comfort and optimal task performance. For this study, a Rubik LED Tunable White fixture with an RGBW system was selected to provide dynamic lighting conditions, ensuring controlled variations in CCT and illuminance while maintaining high energy efficiency and visual comfort.

Appendix 2. Reflectance Calculation Using Luminance Ratios.

Equation:

$$P_{surface} = \frac{L_{surface} \times P_{100\%}}{L_{100\%}}$$

Where:

$P_{surface}$: Reflectance on the Targeted Surface

$P_{100\%}$: Reflectance of 100% Reflectance Surface

$L_{surface}$: Luminance of the Targeted Surface

$L_{100\%}$: Luminance of 100% Reflectance Surface

Appendix 3. Experiment Instruction Crad – Reference used for participants during the experiment, walking them through the experiment steps.

EXPERIMENT INSTRUCTIONS

1. Pick up the box and place it on the desk.
2. Open the box.
3. Take out the questionnaire, Lego set, and instruction cards, and place them on the desk.
4. Put the questionnaire aside.
5. Ring the bell.
6. Build the Lego structure following the instruction cards.
7. Stop immediately when the bell rings and place the Lego structure in the box, finished or not. If you finish early, ring the bell by yourself.
8. Complete the questionnaire within 2 minutes, then ring the bell.
9. Return the questionnaire, instruction cards, Lego structure, and spare pieces to the box, and close it.
10. Place the box on the other side of the desk.
11. Exit the experiment room and wait in the transition space.

Appendix 4. Experiment LEGO Instructions, including nine structures ranging between five to seven pages, numbered alphabetically.

Instructions

1. Prepare the Lego Bricks
 - You should have 20 identical rectangular LEGO bricks.

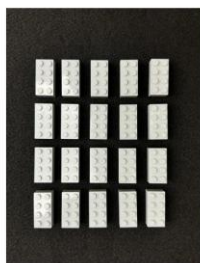

Instructions

2. Build Base Layer
 - Arrange 7 bricks in a rectangular shape to form the base layer.
 - Position the bricks to leave a hollow rectangular space in the center, as shown in the image.

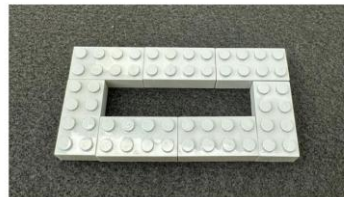

Instructions

3. Build the Second Layer
 - Place another layer of 7 bricks directly on top of the base layer.
 - Ensure the second layer aligns perfectly with the base, following the same hollow rectangular pattern. This is shown in the image.

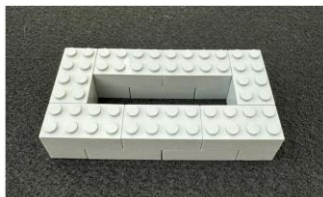

Instructions

4. Build the Third Layer
 - Add 4 bricks on top of the previously built layers, but only on the rectangle's corners, as seen in the image.



Instructions

5. Complete the Structure
 - For the final layer, add 2 bricks on top of the previously built layers at the center of the structure, creating a T-shape.

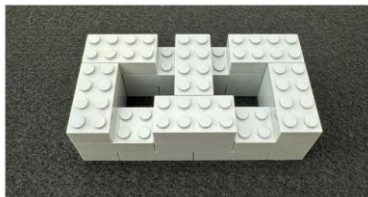

Appendix 4.1. LEGO A Instruction Card.

Instructions

1. Prepare The Lego Bricks
 - You should have 20 identical rectangular LEGO bricks.



Instructions

2. Build the Base Layer
 - Arrange 8 bricks in a rectangular shape to form the base layer.
 - Position the bricks to leave a hollow rectangular space in the center, as shown in the image.

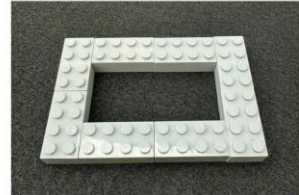

Instructions

3. Build the Second Layer
 - Place another layer of 8 bricks directly on top of the base layer.
 - Align the second layer perfectly with the base, maintaining the same hollow rectangular pattern. This is depicted in the image.

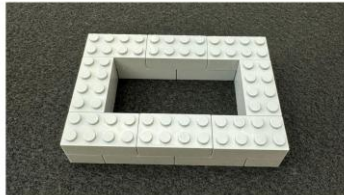

Instructions

4. Build the Third Layer
 - Place 2 bricks on the upper side of the rectangular structure. Place the bricks near the ends while leaving a gap between them as shown in the image.

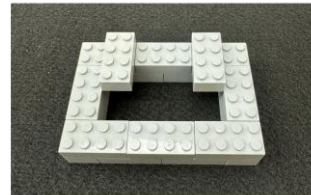

Instructions

5. Complete the Structure
 - Add the final 2 bricks to the lower center side of the rectangular structure, keeping an equal distance from the corners, as seen in the image.

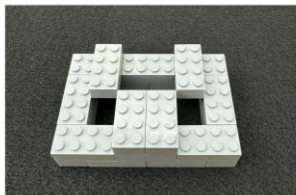

Appendix 4.2. LEGO B Instruction Card.

Instructions

1. Prepare The Lego Bricks
 - You should have 20 identical rectangular LEGO bricks.

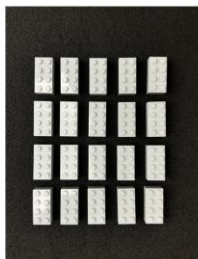

Instructions

2. Build the Base Layer
 - Take 4 brick pieces and place them side by side in 2 parallel rows, with 2 bricks in each row. Ensure they are aligned perfectly and leave a gap between the 2 rows.



Instructions

3. Build the Second Layer
 - Place 3 additional bricks perpendicular to and on top of the bricks added in step 2.



Instructions

4. Build the Third Layer
 - Place a set of 4 bricks on the structure from Step 3. Again, ensure the bricks are placed parallel to the bottom-most layer as shown in the image



Instructions

5. Build the Fourth Layer
 - Repeat the process from Step 2 by placing another set of 3 bricks on top of the structure from Step 4. Again, ensure the bricks are placed perpendicular to the bottom-most layer.



Instructions

6. Complete the Structure
 - Take 6 bricks and attach them to the sides of the structure. Place 3 bricks on each side, attaching them to the base layer, with the bricks facing outward and leaving a gap between each brick.



Appendix 4.3. LEGO C Instruction Card.

Instructions

1. Prepare The Lego Bricks
 - You should have 20 identical rectangular LEGO bricks.

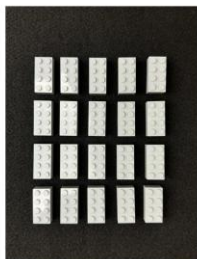

Instructions

2. Build the Base Layer
 - Arrange 4 bricks in a square shape to form the base layer.
 - Position the bricks to leave a hollow square in the center, as shown in the image.



Instructions

3. Build the Second Layer
 - Place another layer of 4 bricks directly on top of the base layer.
 - Align the second layer perfectly with the base, maintaining the same hollow square in the middle. This is shown in the image.



Instructions

4. Add Extensions
 - Place 4 bricks extending outward from the center structure on all four sides, as indicated in the fourth image.
 - Position the extensions so they stick out halfway from each side, forming a cross-like shape.



Instructions

5. Build Up the Top Layer
 - Place another layer of 4 bricks on top of the central structure, aligning them with the extensions from step 4. Refer to the image for proper placement.



Instructions

6. Complete the Structure
 - Add the final 4 bricks on top of the structure on the upper and lower sides to create a solid, raised top. Ensure the final bricks are aligned parallel to the extensions layer from step 4, as shown in the image.



Appendix 4.4. LEGO D Instruction Card.

Instructions

1. Prepare The Lego Bricks
 - You should have 20 identical rectangular LEGO bricks.

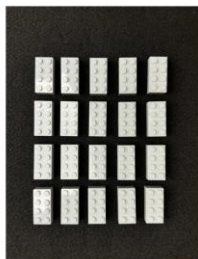

Instructions

2. Build the Base Layer
 - Arrange 8 bricks in two straight lines using 4 bricks for each line and align them next to each other to form the base layer.



Instructions

3. Build the Second Layer
 - Place 4 bricks on top of the base layer, leaving a gap between each brick.
 - Leave a smaller gap for both bricks on the right and left ends.
 - Add 2 bricks on the left end, attaching only half of each brick to the base.

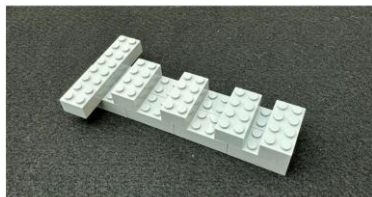

Instructions

4. Add Extensions
 - Place 4 bricks on the right side of the second layer, creating a T-shape.
 - Place 1 brick on the left side, in the center of the bricks, as shown in the image.

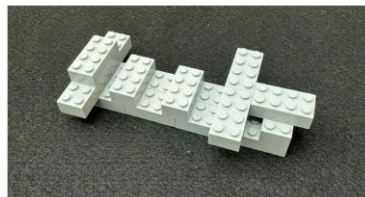

Instructions

5. Complete the Structure
 - Add the final 2 bricks on top of the third layer at the center of the right and left sides, as shown in the image.

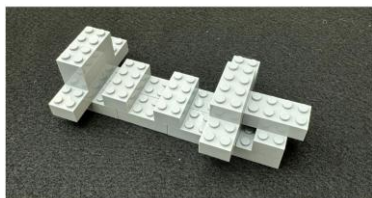

Appendix 4.5. LEGO E Instruction Card.

Instructions

1. Prepare The Lego Bricks
 - You should have 20 identical rectangular LEGO bricks.

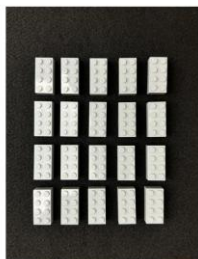

Instructions

2. Build the Base Layer
 - Start by placing 2 bricks side by side to form a small square base, as shown in the image.



Instructions

3. Build the Second Layer
 - Place 2 bricks perpendicular and on top of the base layer, as shown in the image.
 - Repeat this process to form a staircase effect, with each layer offset slightly from the one below.



Instructions

4. Build the Staircase
 - Continue adding layers by placing 2 bricks on top of the existing structure, following the same perpendicular placement as before.
 - Repeat this process until you have built a total of 7 layers, creating a staircase-like structure as shown in the image.

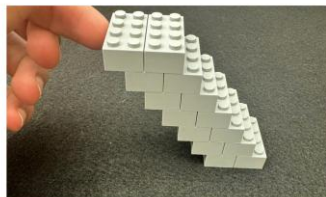

Instructions

5. Create the Arch
 - Once the staircase is complete, build a vertical column by stacking 6 bricks directly on top of each other, as shown in the image.



Instructions

6. Create the Arch
 - Position the column underneath the stair structure for support, as shown in the image.

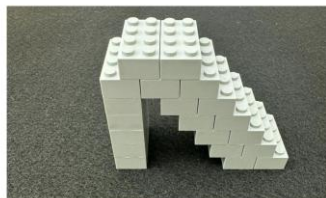

Appendix 4.6. LEGO F Instruction Card.

Instructions

1. Prepare The Lego Bricks
 - You should have 20 identical rectangular LEGO bricks.

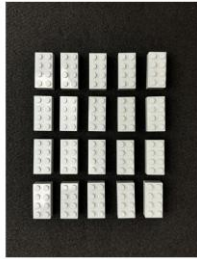

Instructions

2. Build the Base Layer
 - Begin by placing 2 bricks side by side to form a base, as shown in the image.

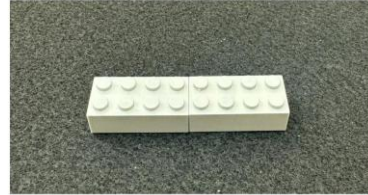

Instructions

3. Construct the Vertical Column
 - Stack 6 bricks on top of the center of the base, aligning them vertically to create a tall column, as shown in the image.



Instructions

4. Add the Horizontal Beam
 - Once the column is complete, add 5 bricks horizontally across the top of the column forming a T-shape beam, as shown in the image.
 - The lower layer of the beam has 2 bricks, while the upper layer has 3 bricks.



Instructions

5. Expand the Horizontal Beam
 - Add 2 more bricks on each side of the horizontal beam, extending the arms of the T-shape, and add 1 brick in the center, as seen in the image.



Instructions

6. Complete the Top Section
 - Add 4 more bricks to create a vertical box on top of the middle section of the horizontal beam. Stack the bricks vertically and connect the box on one side, leaving the opposite side offset, as shown in the image.



Appendix 4.7. LEGO G Instruction Card.

Instructions

1. Prepare The Lego Bricks
 - You should have 20 identical rectangular LEGO bricks.

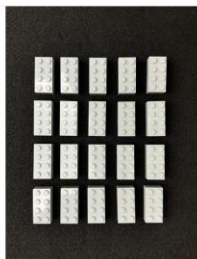

Instructions

2. Build the Base Layer
 - Arrange 4 bricks in a square to form the base layer.
 - Position the bricks so that there is a small hollow square in the center, as shown in the image.

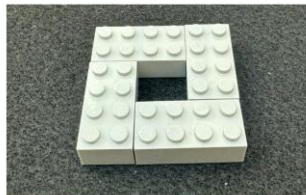

Instructions

3. Build the second layer
 - Place another layer of 4 bricks directly on top of the base layer, aligning them perfectly to create an identical solid square structure with a hollow center.



Instructions

4. Build the Third Layer
 - Add 2 more bricks on top of the previous layer. Place 1 brick on the right and 1 brick on the left side, as shown in the image.



Instructions

5. Build the Fourth Layer
 - Place 3 bricks above the third layer creating an I-shape, as seen in the image.



Instructions

6. Build the Fifth Layer
 - Place 4 bricks in the center, as seen in the image.
 - Placing 2 bricks next to each other and the other 2 on top.



Instructions

7. Complete the Structure
 - Vertically stack the last 3 bricks, creating a column on top of the middle section of the structure.



Appendix 4.8. LEGO H Instruction Card.

Instructions

1. Prepare The Lego Pieces
 - You should have 20 identical rectangular LEGO bricks.

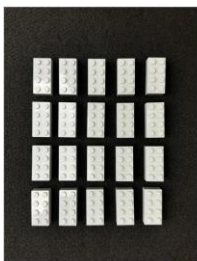

Instructions

2. Build the Base Layer
 - Place 5 bricks side by side to form a line as the base layer, as shown in the image.



Instructions

3. Build the Second Layer
 - Stack another row of 4 bricks directly onto the first row, aligning them parallel to the base layer, as seen in the image



Instructions

4. Build the Third Layer
 - Stack another row of 3 bricks directly on top of the second row, maintaining the alignment to build the third layer, as demonstrated in the image.



Instructions

5. Build the Fourth Layer
 - Stack 4 bricks, creating a box on top of the center of the third layer, as shown in the image.

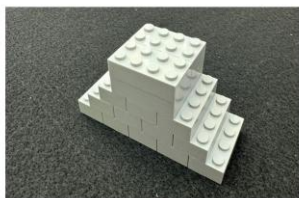

Instructions

6. Build the Top Layer
 - Place 1 brick in the center of the previous row, aligning as shown in the image.



Instructions

7. Complete the Structure
 - Add the final 3 bricks on top of the previous row, ensuring they are centrally aligned to complete the structure, as seen in the final image.



Appendix 4.9. LEGO I Instruction Card.

Appendix 5. Test Room Lighting Fixture Spec Sheet - Rubik's LED Recessed - Tunable White from MARK ARCHITECTURAL LIGHTING.

MARK
ARCHITECTURAL
LIGHTING™

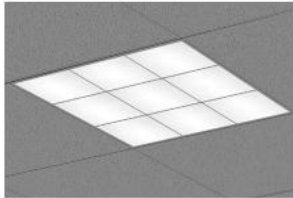

Rubik LED
Recessed - Tunable white

Rubik™ is a revolutionary design vocabulary for the grid. Available in both Productivity and Rhythm ranges, Rubik Tunable White allows the color temperature to be adjusted for optimal occupant performance and experience. 3-cell, 5-cell, and 9-cell luminaires build traditional layouts or unique free-form fields of ambient illumination. Rubik Tunable White is one of four luminous styles offered, along with Static White, Grayscale, and Color Accent. All four luminous styles can be combined in a single ceiling design, and all deliver high quality volumetric lighting for practical performance and design impact. Mainstream Dynamic and nTune™ Technology make it simple with an all-digital control network.

Type: 

Project:

Catalog Number:
DO NOT TYPE HERE. Autopopulated field.

Specification Features

Housing
9-cell (2' x 2'), 25 lbs.; 5-cell (2' x 2'- installer-cutout, 18 lbs.); 3-cell (8" x 2') 12 lbs. Fabricated of 20-gauge cold-rolled galvanized steel.

Finish
Painted after fabrication, high reflectance matte white.

Shielding
High-impact, 90% transmissive acrylic panes sonic welded to injection-molded bezel that provides rigidity across the frame length. Precision-formed steel baffles, powder coated 93% reflectivity white, prevent cell-to-cell light leakage.

Mounting
Recessed. Available 9/16" and 15/16" flat, 9/16" screw slot or 9/16" narrow and 15/16" standard tegular.

A+ Capable Luminaire
This item is an A+ capable luminaire, which has been designed and tested to provide consistent color appearance and out-of-the-box control compatibility with simple commissioning.

- All configurations of this luminaire meet the Acuity Brands' specification for chromatic consistency
- This luminaire is part of an A+ Certified solution for nLight® control networks when ordered with drivers marked by a **shaded background***
- This luminaire is part of an A+ Certified solution for nLight control networks, providing advanced control

 A+ Capable options indicated by this color background.

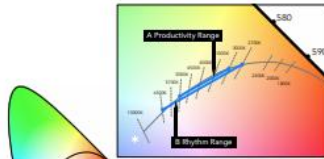

- A** Productivity Range 3000K to 5000K
- B** Rhythm Range 2700K to 6500K

- Tunable White GPHD**
- Gamut:** One dimensional warm-Cool
 - Path:** Direct 3000K to 5000k (Productivity Range) or 2700K to 6500K (Rhythm Range)
 - Handle:** Two Natural Language Handles: Intensity and CCT
 - Data:** nLight with nTune technology for both handles of control

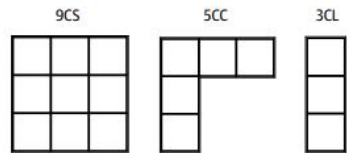
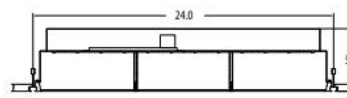

Ordering

Example: RUBIK 9CS DF 90CRI TUWH PROR 240LM DARK NLT 277

Series	Size	Ceiling Trim	LED Color Rendering	Dynamic Feature	Dynamic Range	LED Output ²
RUBIK	9CS 9 cell square	DF ¹ Tegular tee slot	80CRI 80+ CRI	TUWH Tunable white	PROR Productivity range (3000-5000K)	240LM 240 nominal lumens per cell
	5CC 5 cell corner	G9 9/16" inverted tee	90CRI 90+ CRI		RHYR Rhythm range (2700-6500K)	360LM 360 nominal lumens per cell
	3CL 3 cell linear	G15 15/16" inverted tee				440LM 440 nominal lumens per cell

Minimum Dimming Level	Voltage	Emergency Options	Control Interface Type	Options
DARK Constant current, dimming to <1%	120 120V 277 277V 347 347V	E10W ³ 10-watt emergency battery pack BGTD ⁴ Bodine Generator Transfer Device	NLT nLight with nTune interface NLTEMG ⁵ nLight with nTune for use with generator supply EM power.	CP Chicago plenum

Notes

- Available for 9/16" grid only.
- See table for delivered lumens/fixture.
- NLTEMG option requires a connection to an existing powered nLight network.
- Emergency battery assembly remote mount with test switch.
- Must specify 120V or 277V. Bodine GTD provided. When ordered with 2,1, consult project electrical engineer to ensure proper functionality.
- If nLight is required, must also select NLTEMG.

MARK
ARCHITECTURAL
LIGHTING™

Rubik LED
Recessed – Tunable white



Specification Features (continued)

functionality at the luminaire level, when selection includes driver and control options marked by a shaded background*

To learn more about A+, visit www.acuitybrands.com/aplus.

*See ordering tree for details

LED Life

Rated >=50,000 hours (L70) at 25 °C ambient temperature. Rated > 36,000 hours. (L90) at 25 °C ambient temperature.

Color Consistency

The Acuity Brands circuit boards for the linear LED components use a precise binning algorithm which creates a consistent color temperature from board to board. Color variation is no greater than a 2.5 Step MacAdam (2.5SDCM) along the black body locus from board to board.

(<5 step Productivity Range; <8 step Rhythm Range)

Driver

eldoLED constant current driver options delivers ultra-smooth dimming resolution from 100% to <1%, while assuring flicker free, low current inrush, 89% efficiency and low EMI.

Mainstream Dynamic Tunable White with nTune Technology

nTune is an all digital light color temperature control within an nLight enabled luminaire. This brings tunable white lighting control into the mainstream with repeatable, consistent results in an economical luminaire form and system for everyday applications. Designers and facility operators

are granted the freedom to tie scenes to specific activities or to complement colors or materials within a visual environment.

Certification

UL Certified to meet U.S. and Canadian standards, rated for Chicago Plenum, damp locations. Assembled in the USA.

Warranty

5-year limited warranty. Complete warranty terms located at: www.acuitybrands.com/CustomerResources/Terms_and_conditions.aspx

Note: Actual Actual performance may differ as a result of end-user environment and application.

All values are design or typical values, measured under laboratory conditions at 25 °C.

Specifications subject to change without notice.

Government Procurement

BAA - Buy America(n) Act: Product qualifies as a domestic end product under the Buy American Act as implemented in the FAR and DFARS. Product also qualifies as manufactured in the United States under DOT Buy America regulations.

BABA - Build America Buy America: Product qualifies as produced in the United States under the definitions of the Build America, Buy America Act. Please refer to www.acuitybrands.com/buy-american for additional information.

Ceiling Trim

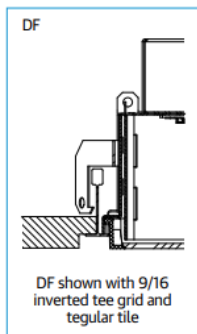
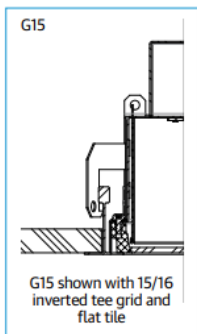
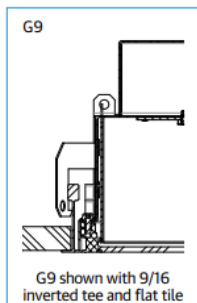
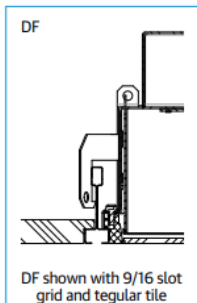

MARK
ARCHITECTURAL
LIGHTING™

Rubik LED
Recessed - Tunable white



Fixture Performance

Dynamic Range	LED Output	CRI	Nominal CCT	Lumens Per Cell	Total Lumens			Lumens Per Watt		
					9CS	5CC	3CL	9CS	5CC	3CL
Productivity (3000K - 5000K)	240 LM	80	3000K	246	2218	1208	732	108	106	101
			4000K	210	1894	1030	623	112	110	105
			5000K	238	2148	1170	708	112	109	105
	240 LM	90	3000K	194	1752	954	578	85	83	80
			4000K	170	1600	871	527	95	92	88
			5000K	203	1836	999	604	96	93	89
	360 LM	80	3000K	384	3460	1884	1120	109	108	101
			4000K	328	2954	1607	955	112	111	104
			5000K	372	3350	1790	1083	110	109	101
	360 LM	90	3000K	303	2733	1488	984	86	85	79
			4000K	259	2496	1357	821	96	94	90
			5000K	318	2864	1558	942	94	95	88
	440 LM	80	3000K	490	4413	2355	1380	112	109	101
			4000K	418	3768	2008	1174	112	109	104
			5000K	474	4274	2281	1335	117	112	104
	440 LM	90	3000K	387	3486	1860	1090	88	86	80
			4000K	330	3184	1732	1048	98	97	94
			5000K	406	3564	1938	1173	98	95	92
Rhythm (2700K - 6500K)	240 LM	80	2700K	232	2091	1137	688	102	99	95
			4000K	230	2072	1127	682	107	105	100
			6500K	242	2182	1187	718	113	110	106
	240 LM	90	2700K	185	1672	909	550	82	79	76
			4000K	194	1750	952	576	91	88	85
			6500K	208	1876	1020	617	97	95	91
	360 LM	80	2700K	362	3262	1776	1073	101	98	101
			4000K	352	3170	1724	1043	104	101	104
			6500K	370	3338	1816	1098	110	107	110
	360 LM	90	2700K	290	2609	1419	858	80	78	86
			4000K	297	2678	1456	881	88	86	88
			6500K	319	2870	1561	944	94	92	94
	440 LM	80	2700K	462	4161	2263	1369	102	101	100
			4000K	449	4040	2197	1329	105	105	105
			6500K	457	4115	2238	1354	107	107	106
	440 LM	90	2700K	369	3328	1810	1095	81	81	80
			4000K	379	3413	1856	1123	89	88	88
			6500K	393	3538	1924	1164	92	91	91

MARK
ARCHITECTURAL
LIGHTING™

Rubik LED
Recessed - Tunable white



Technical Drawing

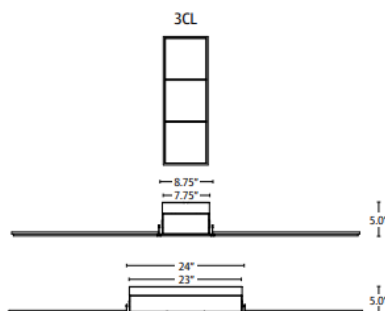
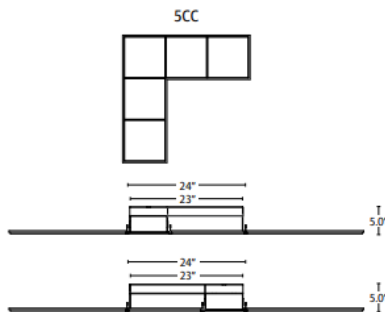
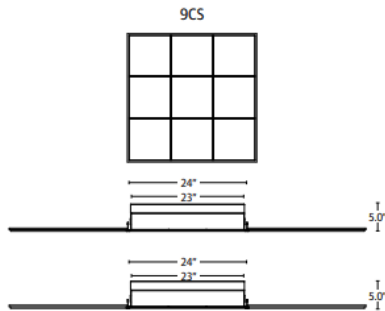

Suggested Wall Pods (order separately)



nPODM 2P DX CCT



nPODM 4S DX



nPODM 4S

Fresco touchscreen



*Compatible with all nLight WallPods

Typical nLight Network Layout

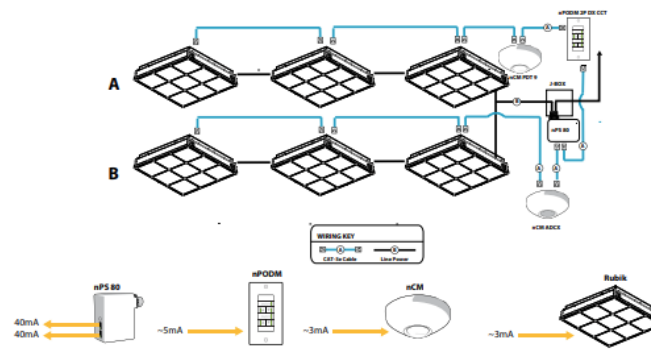



Photometrics

RUBIK 9CS 80CRI TUWH PROR 440LM @3000K, 4244 delivered lumens, 37.6 watts, Test no. ISF 31536P61, tested in accordance to IESNA LM-79

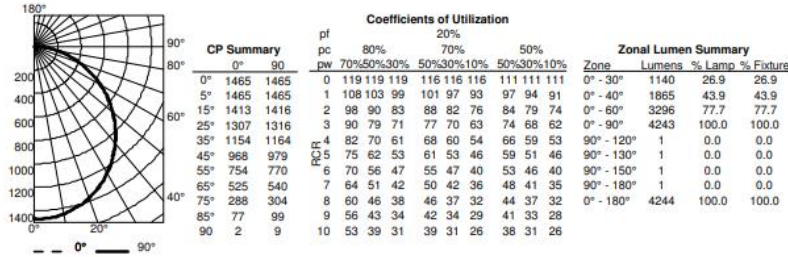

RUBIK 5CC 80CRI TUWH PROR 440LM @3000K, 1500 delivered lumens, 20.6 watts, Test no. ISF 31536P97, tested in accordance to IESNA LM-79

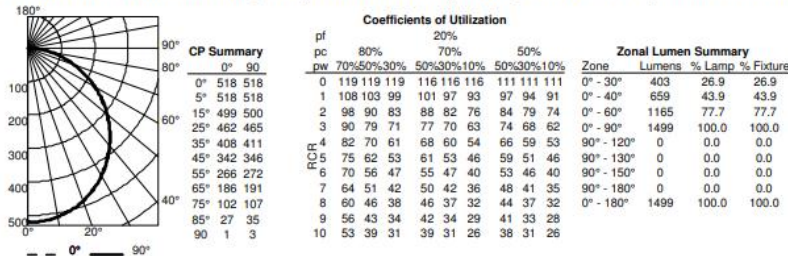

RUBIK 3CL 80CRI TUWH PROR 440LM @3000K, 878 delivered lumens, 12.6 watts, Test no. ISF 31536P79, tested in accordance to IESNA LM-79

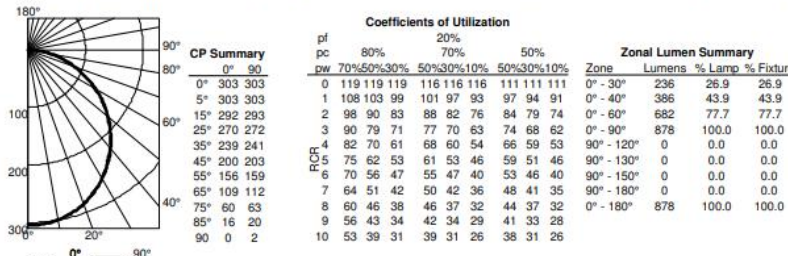

MARK
ARCHITECTURAL
LIGHTING™

Rubik LED
Recessed - Tunable white



Visit <http://www.visual-3d.com/tools/rubik/> for interactive Rubik Design Layout Tool.

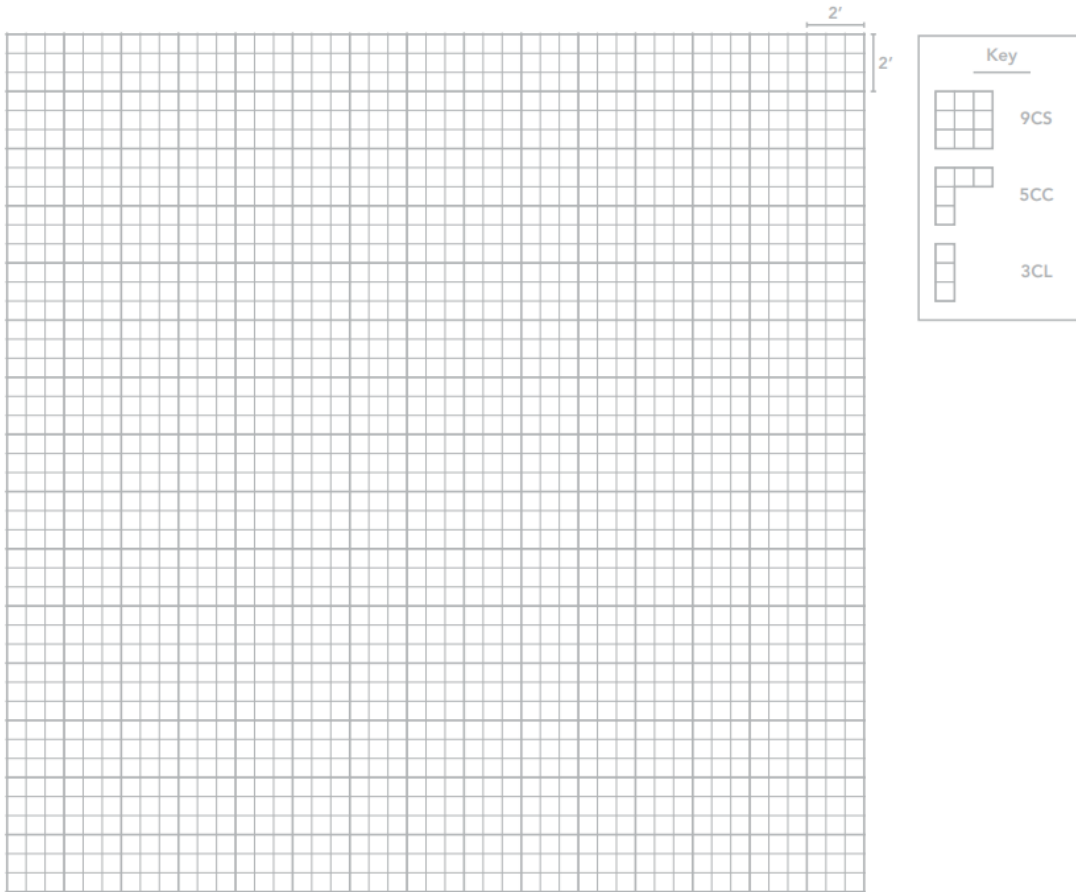

Appendix 6. Excel Randomization Functions for Light Scenes and LEGO Structures.

“=SORTBY(VSTACK(1, 5, 9, INDEX(SORTBY(SEQUENCE(6, 1, 1, 1), RANDARRAY(6)), SEQUENCE(3))), RANDARRAY(6))”

Appendix 3.1. Randomly Shuffle a List of Fixed and Randomly Selected Numbers for Light Scenes: This Excel function combines fixed numbers (1, 5, 9) with three randomly selected numbers from 1 to 6, then shuffles the complete set using random sorting.

“=INDEX(SORTBY(CHAR(SEQUENCE(9, 1, 65, 1)), RANDARRAY(9)), SEQUENCE(6))”

Appendix 3.2. Generate and Randomly Select from Alphabet Subset for LEGO Structures: This Excel function creates a list of the first nine letters of the alphabet, randomly shuffles them, and then selects the first six from this randomized set.

Appendix 7. The Detailed Table Outlining the Randomization of Light Scenes and LEGO Structures for All Cultural Groups (United States (Colorado), Saudi Arabia, and India).

U.S.								
	US1		P1	P2	P3	P4	P5	P6
		Scene	LEGO	LEGO	LEGO	LEGO	LEGO	LEGO
		7	I	A	D	H	E	H
		3	E	D	C	C	F	C
		9	A	C	G	A	I	I
		5	F	H	B	B	A	D
		6	H	E	I	E	D	G
		1	D	I	A	I	G	A
	US2		P1	P2	P3	P4	P5	P6
		Scene	LEGO	LEGO	LEGO	LEGO	LEGO	LEGO
		9	H	G	C	A	A	A
		1	B	C	I	I	H	E
		8	A	F	H	G	D	D
		6	D	I	G	F	C	G
		5	G	H	D	B	F	B
		4	C	A	A	D	E	I
	US3		P1	P2	P3	P4	P5	P6
		Scene	LEGO	LEGO	LEGO	LEGO	LEGO	LEGO
		6	D	B	A	A	H	C
		9	C	C	I	E	G	E
		1	I	I	G	F	I	A
		4	A	H	C	D	C	F
		5	E	A	B	H	F	I
		8	G	D	H	I	A	B
	US4		P1	P2	P3	P4	P5	P6
		Scene	LEGO	LEGO	LEGO	LEGO	LEGO	LEGO
		2	I	D	C	C	F	I
		9	D	E	D	I	D	H
		1	C	I	B	H	A	B
		4	F	C	A	F	E	D
		5	B	G	H	E	H	E
		6	G	F	I	A	I	A
	US5		P1	P2	P3	P4	P5	P6
		Scene	LEGO	LEGO	LEGO	LEGO	LEGO	LEGO
		7	G	H	C	E	D	F
		2	D	B	F	D	E	E
		6	F	G	D	C	F	B
		1	E	C	B	H	I	D
		9	C	A	A	G	G	A
		5	I	D	H	F	B	H

Appendix 4.1. United States (Colorado) Light Scenes and LEGO Structures Randomization.

Saudi Arabia								
	SA1		P1	P2	P3	P4	P5	P6
		Scene	LEGO	LEGO	LEGO	LEGO	LEGO	LEGO
		1	I	E	D	F	I	A
		4	F	B	A	B	A	B
		9	E	H	F	A	E	I
		5	D	C	B	H	C	D
		2	B	D	E	E	H	E
		6	C	G	I	I	F	G
	SA2		P1	P2	P3	P4	P5	P6
		Scene	LEGO	LEGO	LEGO	LEGO	LEGO	LEGO
		1	G	I	D	B	D	E
		5	F	F	C	A	E	H
		4	A	C	A	E	F	C
		2	D	A	H	F	C	A
		9	I	D	I	I	A	G
		6	C	E	G	G	G	B
	SA3		P1	P2	P3	P4	P5	P6
		Scene	LEGO	LEGO	LEGO	LEGO	LEGO	LEGO
		6	F	F	B	I	D	G
		4	H	A	D	D	H	I
		5	B	E	F	B	E	D
		7	A	H	G	F	G	E
		1	C	G	C	H	I	A
		9	E	I	E	A	B	B
	SA4		P1	P2	P3	P4	P5	P6
		Scene	LEGO	LEGO	LEGO	LEGO	LEGO	LEGO
		1	E	H	C	F	F	B
		4	F	B	I	D	G	G
		5	D	D	A	I	I	C
		9	C	I	H	E	D	I
		6	A	F	G	A	C	H
		3	G	A	E	B	A	E
	SA5		P1	P2	P3	P4	P5	P6
		Scene	LEGO	LEGO	LEGO	LEGO	LEGO	LEGO
		1	C	A	F	A	F	D
		2	F	I	G	D	I	F
		5	G	F	C	I	A	C
		9	E	E	A	F	E	I
		4	I	C	I	C	D	G
		8	H	B	E	G	B	A

Appendix 4.2. Saudi Arabia Light Scenes and LEGO Structures Randomization.

India								
	IN1		P1	P2	P3	P4	P5	P6
		Scene	LEGO	LEGO	LEGO	LEGO	LEGO	LEGO
		5	G	C	F	A	F	F
		3	H	G	B	E	H	G
		9	I	I	G	F	G	A
		1	C	A	A	B	C	I
		6	F	E	C	D	D	H
		7	A	D	D	C	B	E
	IN2		P1	P2	P3	P4	P5	P6
		Scene	LEGO	LEGO	LEGO	LEGO	LEGO	LEGO
		5	F	F	I	B	H	F
		2	D	G	G	A	I	D
		8	G	A	H	D	C	H
		7	I	C	E	C	F	A
		9	E	E	C	G	B	C
		1	H	I	F	C	A	I
	IN3		P1	P2	P3	P4	P5	P6
		Scene	LEGO	LEGO	LEGO	LEGO	LEGO	LEGO
		7	B	G	F	F	I	F
		9	D	A	G	B	A	I
		5	C	I	H	C	H	E
		1	E	B	C	E	B	C
		8	H	C	A	I	E	A
		4	A	F	B	A	C	G
	IN4		P1	P2	P3	P4	P5	P6
		Scene	LEGO	LEGO	LEGO	LEGO	LEGO	LEGO
		1	I	B	C	H	I	D
		9	E	C	A	E	F	B
		5	A	E	G	D	H	H
		2	B	G	E	A	B	G
		4	G	F	H	B	D	E
		3	C	I	B	I	E	I
	IN5		P1	P2	P3	P4	P5	P6
		Scene	LEGO	LEGO	LEGO	LEGO	LEGO	LEGO
		1	I	E	D	F	I	A
		5	F	B	A	B	A	B
		7	E	H	F	A	E	I
		8	D	C	B	H	C	D
		3	B	D	E	E	H	E
		9	C	G	I	I	F	G

Appendix 4.2. India Light Scenes and LEGO Structures Randomization.

Appendix 8. DMX Controller – SLESA-U9 from NICOLAUDIA ARCHITECTURE.

SLESA-U9



Sunlite Easy Stand Alone USB-DMX controller



Overview

The most cost-effective version of our standalone DMX interfaces for applications where simplicity and reliability are very important.

Able to control 256 channels (*now upgradable to 512) in a single zone, allowing for the playback of dynamic and highly detailed scenes. DMX output via a 3 pin XLR socket. Scenes are triggered via push buttons or dry contacts.

Perfect for integrators or manufacturers as it can be supplied with or without an XLR socket.

nicolaudie.com/slesa-u9

Key Features

- USB connection
- 256 DMX512 channels universe in stand alone *
- 256 DMX512 channels universe in live mode *
- Upgradable to 512 channels online using SUT
- 8 dry contact trigger ports via HE10 connector
- Stand alone mode with 1 area and 20 scenes
- Buttons for changing scenes and dimmer
- OEM customization

* SUT (Sunlite Upgrade Technology)

The interface is compatible with SUT (Smart Upgrade Technology). If you need more DMX channels or compatibility with different software, SUT allows for an easy upgrade. You can also purchase licences for any other Nicolaudie Group software. Free 30 days trials available on most upgrades. Find out more at store.nicolaudie.com

Technical Data

Input Power	5-5.5V DC 0.6A
Output Protocol	DMX512 256 channels Standalone * 256 channels Live *
Programmability	PC, Mac
Available Colors	Blue, Orange, Gray, Green, Marine, White, Red
Connections	Mini USB, XLR3, HE10
Memory	internal flash
Environment	IP20. 0°C - 50°C
Buttons	2 buttons to change scene + 1 button to change area
Dimensions	79x92x43mm 120g Complete Package 140x135x50mm 340g
OS Requirements	Mac OS X 10.13.6+ Windows 10/11
Standards	EC, EMC, ROHS

Optional Accessories

POWER1_EU/UK/US 5V ACDC power supply with EU/UK/US plug

	Sunlite Easy Stand Alone USB-DMX Interface	SLESA-U9	Version
	Technical datasheet	Revision date 11 Nov 2024	www.nicolaudie.com

CONNECTIVITY

Live Use with a Computer



PORTS SETUP

Connect any of the port pins with the ground pin to trigger a volt free dry contact port. Ports can be combined in binary to have up to 255 triggers.



EXTERNAL HE10



- P1 PORT 1
- P2 PORT 2
- P3 PORT 3
- P4 PORT 4
- P5 PORT 5
- P6 PORT 6
- P7 PORT 7
- P8 PORT 8
- GND Ground

Internal HE10



- 1 GND
- 2 DIMMER
- 3 DMX 1+
- 4 PREVIOUS
- 5 DMX 1-
- 6 NEXT
- 7 UNUSED
- 8 DMX LED
- 9 VUSB 5V*
- 10 USB LED

CAUTION: DO NOT SHORT THE USB

Standalone Use

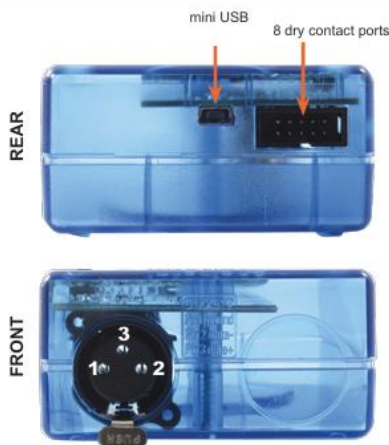

- 1 DMX1 ground
- 2 DMX1 data-
- 3 DMX1 data+

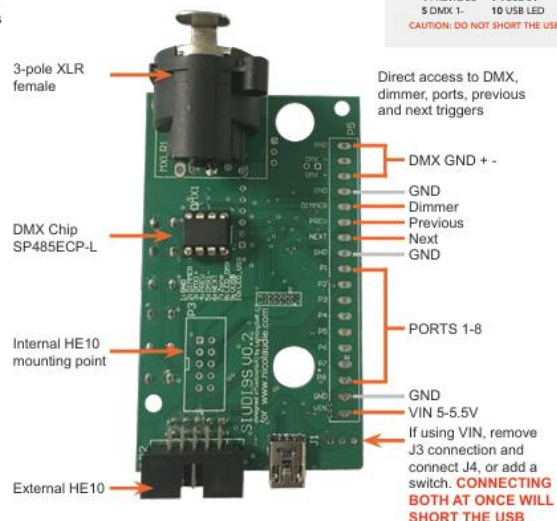

Nicolaudie Software

To program your controller download ESA2 or ESA Pro 2 from www.nicolaudie.com/downloads
Use HardwareManager to manage your controller and update firmware.

To buy upgrades, software and apps, go to : store.nicolaudie.com

 siudi <small>SUNLITE INTELLIGENT USB DMX INTERFACE</small>	Sunlite Easy Stand Alone USB-DMX Interface	SLESA-U9	Version
	Technical datasheet	Revision date 11 Nov 2024	www.nicolaudie.com

Troubleshooting

The controller is not detected by the computer

- Be sure that the latest software version is installed from our website nicolaudie.com/download
- Connect by USB and open the Hardware Manager (found in the software directory). If it is detected here, try to update the firmware. If it is not detected, try the method below.
- **Bootloader Mode**
Sometimes the firmware update may fail and the device may not be recognized by the computer. Starting the controller in 'Bootloader' mode forces the controller to start in a simpler mode and in some cases allows the controller to be detected and the firmware to be written. To force a firmware update in Bootloader Mode :
 1. Power off and disconnect your interface from all cables.
 2. Use a crosshead screw driver to remove two screws on the bottom. One may be hidden under the circular label.
 2. Remove the bottom case and carefully remove circuit board (PCB).
 4. Open HardwareManager on your computer.
 5. Look for the word 'BootLoader' on the PCB. You will see 2 rectangular solder pads (see 4, image below).

To trigger Bootloader mode

- a) use an electro-conductive object (e.g. flat head screw driver) to temporarily connect the two solder points.
 - b) At the same time, connect the USB cable to your computer.
6. Your device should appear in HardwareManager with the suffix `_BL`
 4. Update the firmware and restart the device in standard mode.

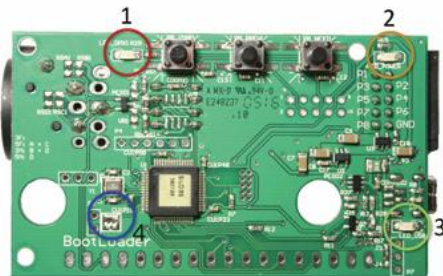

The lights are not responding

- Check the DMX +, - and GND are connected correctly
- Check that the driver or lighting fixture is in DMX mode
- Be sure that the DMX address has been set correctly
- Check there are no more than 32 devices in the chain
- Check that the red DMX LED is flickering. There's one by each XLR
- Connect with the computer and open Hardware Manager (found in the software directory). Open the DMX Input/Output tab and move the faders. If your fixtures respond here, it is possibly a problem with the show file

What do the LED's on the controller signify

- Red (1) : Flickering indicates DMX activity
- Yellow (2) : The device is receiving power
- Green (3) : USB activity

Appendix 9. Experiment Informed Consent Document.

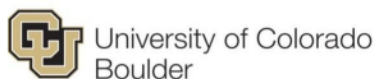

Permission to Take Part in a Human Research Study

Page 1 of 3

Title of research study: Assessing the Influence of Cultural Backgrounds on Lighting Preferences and Their Impact on Visual Performance.

IRB Protocol Number: 24-0434

Investigator: Jennifer Scheib

Purpose of the Study

The purpose of the research is to assess the need for new design guidance for architectural lighting that varies based on the cultural background of occupants. This project will investigate the correlation between subjects' preferences and performance under various lighting conditions and their cultural background. We expect that you will be in this research study for 60 minutes and a three-day log to be completed three days before the experiment. A total of 120 people will participate in the study. Whether or not you take part in this research, it is your choice. You can leave the research at any time, and it will not be held against you.

Explanation of Procedures

You will have one study visit, lasting about 60 minutes, and a three-day log three days before the experiment. Here's what to expect:

Once you sign up in the sign-up sheet, you'll get an email (this email) with instructions about the testing procedure. Feel free to ask any questions about these instructions via email. Along with these instructions, you'll receive a pre-experiment questionnaire. This will ask for basic information like your name, gender, optional religion, cultural background, past places you've lived, lighting preferences at work, chronotype, and sleep pattern. You'll also receive a three-day log asking you to rate your mood for three days on a scale of 1 to 7. Also, we will ask you to document your sleep hours on the three-day log. You can submit the questionnaire online through Qualtrics in the links attached to the email before coming in for the experiment. You can decide not to participate after reading the instructions.

When you arrive at the lighting lab, you'll wait in a room where a video will explain the test procedure and a set of Legos will be provided for you to practice on. In the test room, you'll sit at a desk in the center and experience 6 different lighting scenes with varying brightness and color temperatures. You'll complete a model-building task using Lego and printed instructions. This task should take 5 minutes or less, and your time will be recorded. After



Exempt Determination Date

IRB Document Revision Date: January 22, 2024
 TEMPLATE – Exempt In-Person Consent

each task, you'll complete a questionnaire about the room's lighting quality, visual performance, and mood. All answers will be recorded on paper.

During the first and only visit to the University of Colorado Boulder Engineering Center Lighting Lab, you will spend 20 minutes in the waiting room watching a video outlining the test procedure and practicing a Lego set. Following this, you will move to the test room for 45 minutes. Here, you will undergo 6 different lighting scenes with changes in lighting intensities and correlated color temperatures and answer questions related to visual performance, self-reported mood, and the perceived light quality of the space. You will also be tasked with building a Lego structure according to instructions. Between each lighting scene, you will be asked to sit in a transition space next to the test room as we change the light scene.

This process will be repeated for all 6 lighting scenes. The experiment will end once all scenes are completed, and the test questionnaire is filled out.

To ensure the reliability and validity of the results, the sequences of the lighting scenes will be randomized for each participant. This approach minimizes the potential for order effects, ensuring that the results more accurately reflect the influence of lighting conditions rather than the sequence in which they are presented.

The study will be a repeated measurement design in which you will respond to your perception of one physical and multiple lighted scenes (same geometry but different intensities and CCT of light).

There will be a minimum of 30 participants from each cultural group, with a goal of 4 cultural groups for a maximum of 120 participants. You will have one study visit, lasting 60 minutes. The research will be conducted on the University of Colorado campus within the Engineering Center Lighting Lab during the fall of 2024. During the visit, you will interact with the principal investigator (PI) and the advisor from industry. You will be the only person in the testing room during the experiment. All materials, including the desk and materials for evaluating task performance, will be sanitized between each participant.

Confidentiality

Information obtained about you for this study will be kept confidential. The information from this research may be published for scientific purposes; however, your identity will not be given out. Research information that identifies you may be shared with the University of Colorado Boulder Institutional Review Board (IRB) and others who are responsible for ensuring compliance with laws and regulations related to research, including people on behalf of the Office for Human Research Protections. The information from this research may be published for scientific purposes; however, your identity will not be given out. All study data will be stored securely and only accessed by study staff.

Exempt Determination Date

IRB Document Revision Date: January 22, 2024
TEMPLATE – Exempt In-Person Consent

Questions

If you have questions about the research, you can contact the Principal Investigator at Jennifer.Schieb@colorado.edu

If you have concerns or complaints about the research, you can contact the CU Boulder IRB at (303) 735-3702 or irbadmin@colorado.edu if:

Signatures

Your signature documents your permission to take part in this research.

Signature of subject

Date

Printed name of subject

Signature of person obtaining consent

Date

Printed name of person obtaining consent

Exempt Determination Date

IRB Document Revision Date: January 22, 2024
TEMPLATE – Exempt In-Person Consent

Appendix 10. Pre-Experiment Phase, Demographic Questionnaire - Only questions with a star were included in the final study for the data analysis.

Q1 - Name (First & Last)

Q2 - CU Email Address

Q3 - What is your age?

*Q4 - What is your gender (Male/Female/Other)?

*Q5 - List the countries and cities where you have lived throughout your life (e.g.,

Lisbon, Portugal (2021 - 2023)

Q6 - If you are a student, what is your major?

*Q7 - Do you wear eye correction devices such as contacts or glasses?

*Q8 - Do you have any visual impairments (e.g., YES- color blindness, low vision, cataracts) or NO?

Q9 - Are you prone to dizziness or lightheadedness in different lighting situations (e.g., change in light intensity and light color)?

Q10 - Are you religious? If so, state your religion. If not, or if you prefer not to answer, use N/A.

Q11 - Do you have any lighting design knowledge?

Q12 - When do you feel most active, in the morning or evening?

Q13 - What hours of the day do you typically wake up and go to sleep? (##:## AM or PM & ##:### AM or PM).

Q14 - How would you describe your sleep quality?

Q15 - How would you describe your current lighting setup in your work or study space (high/low light levels, white or yellow light colors)?

*Q16 - How many minutes/hours were you exposed to sunlight before arriving at the laboratory (Answer before arriving at the experiment)?

*Q17 - Sleep Recommendation For optimal performance during the experiment, it is recommended that each participant get at least seven hours of sleep per night in the week leading up to their scheduled experiment. Compliance with this recommendation is optional. Answer YES to complete the form.

Appendix 11. Pre-Experiment Phase, PANAS-SF One-Day Mood Log. The mood log also included a section for recording sleep hours.

Indicate the extent you have felt this way today

	Very Slightly or not at all	A little	Moderately	Quite a bit	Very much	Almost extremely	Extremely
Interested	<input type="radio"/>	<input type="radio"/>	<input type="radio"/>	<input type="radio"/>	<input type="radio"/>	<input type="radio"/>	<input type="radio"/>
Distressed	<input type="radio"/>	<input type="radio"/>	<input type="radio"/>	<input type="radio"/>	<input type="radio"/>	<input type="radio"/>	<input type="radio"/>
Excited	<input type="radio"/>	<input type="radio"/>	<input type="radio"/>	<input type="radio"/>	<input type="radio"/>	<input type="radio"/>	<input type="radio"/>
Upset	<input type="radio"/>	<input type="radio"/>	<input type="radio"/>	<input type="radio"/>	<input type="radio"/>	<input type="radio"/>	<input type="radio"/>
Strong	<input type="radio"/>	<input type="radio"/>	<input type="radio"/>	<input type="radio"/>	<input type="radio"/>	<input type="radio"/>	<input type="radio"/>
Guilty	<input type="radio"/>	<input type="radio"/>	<input type="radio"/>	<input type="radio"/>	<input type="radio"/>	<input type="radio"/>	<input type="radio"/>
Scared	<input type="radio"/>	<input type="radio"/>	<input type="radio"/>	<input type="radio"/>	<input type="radio"/>	<input type="radio"/>	<input type="radio"/>
Hostile	<input type="radio"/>	<input type="radio"/>	<input type="radio"/>	<input type="radio"/>	<input type="radio"/>	<input type="radio"/>	<input type="radio"/>
Enthusiastic	<input type="radio"/>	<input type="radio"/>	<input type="radio"/>	<input type="radio"/>	<input type="radio"/>	<input type="radio"/>	<input type="radio"/>
Proud	<input type="radio"/>	<input type="radio"/>	<input type="radio"/>	<input type="radio"/>	<input type="radio"/>	<input type="radio"/>	<input type="radio"/>
Irritable	<input type="radio"/>	<input type="radio"/>	<input type="radio"/>	<input type="radio"/>	<input type="radio"/>	<input type="radio"/>	<input type="radio"/>
Alert	<input type="radio"/>	<input type="radio"/>	<input type="radio"/>	<input type="radio"/>	<input type="radio"/>	<input type="radio"/>	<input type="radio"/>
Ashamed	<input type="radio"/>	<input type="radio"/>	<input type="radio"/>	<input type="radio"/>	<input type="radio"/>	<input type="radio"/>	<input type="radio"/>
Inspired	<input type="radio"/>	<input type="radio"/>	<input type="radio"/>	<input type="radio"/>	<input type="radio"/>	<input type="radio"/>	<input type="radio"/>
Nervous	<input type="radio"/>	<input type="radio"/>	<input type="radio"/>	<input type="radio"/>	<input type="radio"/>	<input type="radio"/>	<input type="radio"/>
Determined	<input type="radio"/>	<input type="radio"/>	<input type="radio"/>	<input type="radio"/>	<input type="radio"/>	<input type="radio"/>	<input type="radio"/>
Attentive	<input type="radio"/>	<input type="radio"/>	<input type="radio"/>	<input type="radio"/>	<input type="radio"/>	<input type="radio"/>	<input type="radio"/>
Jittery	<input type="radio"/>	<input type="radio"/>	<input type="radio"/>	<input type="radio"/>	<input type="radio"/>	<input type="radio"/>	<input type="radio"/>
Active	<input type="radio"/>	<input type="radio"/>	<input type="radio"/>	<input type="radio"/>	<input type="radio"/>	<input type="radio"/>	<input type="radio"/>
Afraid	<input type="radio"/>	<input type="radio"/>	<input type="radio"/>	<input type="radio"/>	<input type="radio"/>	<input type="radio"/>	<input type="radio"/>

Record the number of hours you slept

Appendix 12. Experimental Phase – 7-Point Likert Scale Experiment Questionnaire answered after each light scene indicating preference. Only questions with a star were included in the final study for the data analysis.

Indicate the extent to which you have thought during this lighting condition

Lights are too bright

Very slightly or not at all

Extremely

1 2 3 4 5 6 7

Lights are too dim

Very slightly or not at all

Extremely

1 2 3 4 5 6 7

I like the color of light

Very slightly or not at all

Extremely

1 2 3 4 5 6 7

*I like the lighting scene

Very slightly or not at all

Extremely

1 2 3 4 5 6 7

Appendix 13. Pre-Experiment Phase Demo LEGO Structure. The structure is shown in the experiment instruction video.

Instructions

1. Prepare The LEGO Pieces

- You should have 20 identical rectangular LEGO bricks.

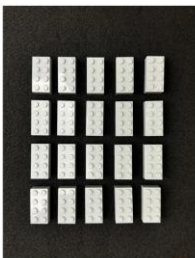

Instructions

3. Build the Sides

- **First Side:** Stack 3 additional bricks on top of the first square, aligning them directly on top of each other to form a wall, as shown in the image.
- **Second Side:** Repeat the same step for the other square, creating 2 identical structures.

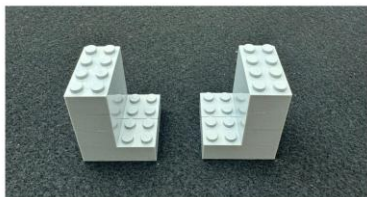

Instructions

5. Add the Roof

- Place 4 bricks on top of the middle section of the W-shaped structure to form a flat surface, as shown in the image.



Instructions

2. Build the Base Layer

- **First Section:** Place 2 bricks to form a square, as shown in the image.
- **Second Section:** Repeat the same step to create another square with the next 2 bricks.



Instructions

4. Connect the Sides

- Place 2 bricks horizontally to connect the two walls
- Add an additional 2 bricks vertically on top of them, creating a W-shaped structure, as shown in the image.

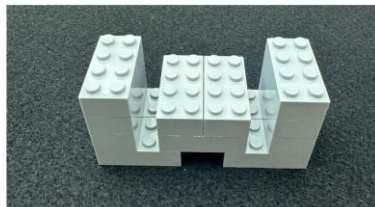

Instructions

6. Complete the Structure

- Stack the remaining two bricks on top of the structure, placing them in the center to add height, as shown in the image.



Appendix 14. Konica Minolta T-10A Illuminance Meter Brochure.



KONICA MINOLTA

Compatible with PWM-controlled sources

Illuminance Meter T-10A series

*Illuminance meters that conform to JIS AA Class and DIN Class B requirements.
Compatible with new, next-generation light sources including PWM-controlled sources*



Can be used for simple, inexpensive multi-point measurements. Mini receptor model also available to enable illuminance measurements even in narrow spaces.

The Standard in Measuring Color & Light

Giving Shape to Ideas

For simple but accurate illuminance measurements. Makes creating illuminance measurement systems such as multi-point measurement systems easy!

Reliable, worry-free illuminance meters that conform to JIS AA Class and DIN Class B

Illuminance Meters T-10A and T-10MA conform to Class AA of JIS C 1609-1:2006 "Illuminance meters Part 1: General measuring instruments" and DIN 5032 Part 7 Class-B * Photometry; classification of illuminance meters and luminance meters* requirements to provide high-accuracy, high-reliability, worry-free measurements.

Illuminance meters conforming to these standards are required for measurements of general illumination light sources, white LED lamps for illumination, etc. in a variety of industrial fields.

Removable receptor

The receptor and main body can be detached from each other and then connected using a LAN cable, making it easy to install as part of an inspection system.

Compatible with PWM-controlled lighting. Enables measurements of next-generation light sources.

Conventional illuminance meters often cannot accurately measure PWM-controlled light sources, but the T-10A series of illuminance meters can be used to accurately measure even such light sources.

Easy, inexpensive multi-point measurement (2 to 30 points).

Illuminance distribution of a projector, etc. can be easily measured with a single instrument and several receptors.



Multi-point illuminance measuring system

- 5-point example: Architectural lighting, etc.
- 9-point example: Projectors, etc.
- 25-point example: Street lighting, etc.

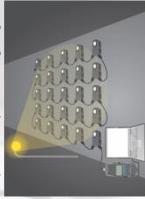

[T-10A 9-point measuring system composition]
 Illuminance Meter T-10A 1 unit
 Receptor T-10MA 9 units
 Adapter units for Main Body FA20 9 units
 AC Adapter 1 unit
 Data Management Software T-SD0w 1 unit

Main applications

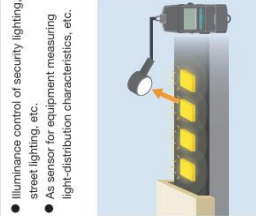

- Government testing organizations
- Research/inspection at illumination equipment makers
- Maintenance at factories, offices, hospitals, etc.
- Illuminance control of security lighting, street lighting, etc.
- As sensor for equipment measuring light-distribution characteristics, etc.

<Standard receptor>
T-10A

Receptor diffuser window: Ø 25 mm

<Mini receptor>
T-10MA/T-10W_sA/T-10W_LA

Receptor diffuser window: Ø 14 mm

T-10A

Conforms to JIS AA Class and DIN class B

Can be used for general measurements of illuminance.

T-10MA (Cord length: 1 m)

Conforms to JIS AA Class and DIN class B

Enables illuminance measurements of small areas.

Can be used for illuminance measurements in narrow spaces where the standard receptor won't fit. It can also be easily installed on various kinds of equipment or jigs for measuring light levels such as illumination.

T-10W_sA (Cord length: 5 m)
T-10W_LA (Cord length: 10 m)

Conforms to JIS requirements for special illuminance meters

Waterproof Custom order

The mini receptor and cord are both waterproof, so they can be used for measurements in water. They can be used for illuminance control for fishery-related applications (such as fish farming, etc.) or for measuring outdoor illuminance on rainy days.

multi-point measurement systems easy!

Data Management Software T-S10w (Optional accessory)

Convenient, easy-to-use Excel® add-in software

Reads measurement data from T-10A series Illuminance Meters directly into Excel®. Further processing of data can then be performed easily using the various functions of Excel®.

Main specifications of Data Management Software T-S10w

Type	Add-in for Excel®
Operating environment	Excel® is required to use this add-in. OS: Windows® 10 Pro, 32bit/64bit, Windows® 11 Pro, 32bit/64bit
Language	OS language: English, Japanese, Simplified Chinese, Traditional Chinese Application: English, Japanese, Simplified Chinese, Traditional Chinese
Version	Excel® 2019/32bit Excel® 2019/64bit
Compatibility	For details on system requirements for the above versions of Windows® and/or Excel®, refer to their respective specifications.
Measurement	T-10A/10A1, T-10A1, T-10AA, T-10AA1, T-10AA1, T-10AA1, T-10AA1

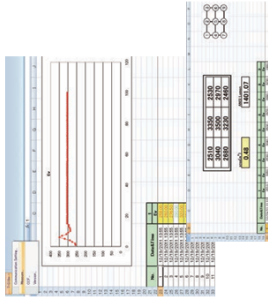

Relative Spectral Responsivity

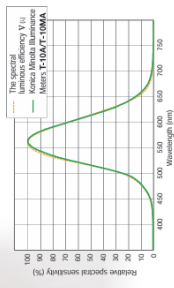

Ideally, the relative spectral responsivity of the illumination meter should match $V(\lambda)$ of the human eye for photopic vision. As shown in the graph above, the relative spectral responsivity of Konica Minolta Illuminance Meters T-10A/10AA is within 6% (1) of the CIE spectral luminous efficiency $V(\lambda)$.

CIE: Commission Internationale de l'Éclairage
1) (CIE symbol): The degree to which the relative spectral responsivity matches $V(\lambda)$ is characterized by means of the error 1%.

Cosine Correction Characteristics

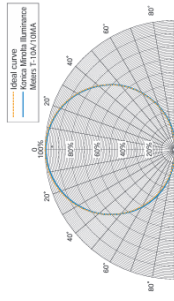

Since the brightness at the measurement plane is proportional to the cosine of the angle at which the light is incident, the response of the receptor must also be proportional to the cosine of the incidence angle.

For Konica Minolta Illuminance Meters T-10A/10AA, the response is proportional to the cosine of the incidence angle. The graph above shows the cosine correction characteristics of Konica Minolta Illuminance Meters T-10A/10AA.

About PWM-controlled lighting

PWM is the abbreviation of Pulse Width Modulation, and refers to the method of controlling signal intensity by controlling the ratio between the ON period and OFF period of a pulse signal. A signal which repeatedly alternates between ON and OFF is referred to as a "duty cycle". PWM-controlled lighting is a method for controlling the brightness of a lamp by controlling the duty cycle (it time) of light from a pulse-emission source. As the lit time becomes longer, the light becomes brighter, and conversely, as the lit time becomes shorter the light becomes darker.

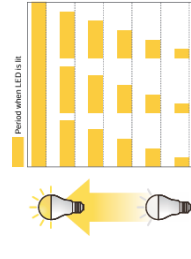

Konica Minolta's Illuminance Measurement Trio

Konica Minolta's line of instruments for measuring illuminance includes not only the Illuminance Meter T-10A which can measure PWM-controlled light sources, but also the Chroma Meter CL-200A which can measure color temperature and the Illuminance Spectrophotometer CL-500A which can measure color-rendering properties.

Illuminance meter that can handle PWM-controlled lighting

Illuminance Meter T-10A

Conforms to DIN Class B and JIS AA Class.
Capable of accurately measuring next-generation lamps including PWM-controlled lighting.
Multiple receptors can be used for easy, low-priced, multi-point measurement, and a miniature receptor model is also available for easily measuring illuminance in narrow spaces.

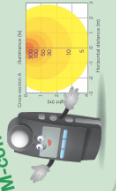

Measures color temperature

Chroma Meter CL-200A

A de facto industry standard for color-temperature measurement. Can also perform illuminance measurements (JIS AA Class). Compact and lightweight with removable receptor connectable with extension cables.
Includes simple, convenient PC software as standard accessory.

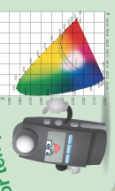

Measures color-rendering properties

Illuminance Spectrophotometer CL-500A

The first illuminance spectrophotometer to conform to both JIS AA Class and DIN Class B requirements.
Compact, handheld type can easily be installed in inspection equipment and is ideal for evaluating color-rendering properties. Includes simple, convenient PC software as a standard accessory.

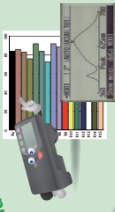

* Both CL-200A and CL-500A can measure PWM-controlled lighting.

Illuminance measurement with the CS-3000 series spectroradiometer

An adapter that attaches to the lens unit to enable spectral irradiance measurement with a spectrum wavelength width of 5 nm or less, and accuracy conforming to Class AA general illuminance meter of JIS C 1609-1:2006 (Illuminance Meters Part 1, General Measuring Instruments).

When you remove the illuminance adapter, it reverts to a spectroradiometer, so it serves two purposes.

The CS-3000 series has three models in its lineup: the flagship model CS-3000HDR, the standard model CS-3000, and the cost-effective model CS-2000Plus, which is a high-speed calculation CPU and a new algorithm, INTELLIGENT DARK function, based on the conventional CS-2000 model.

Measurement illuminance range (With CS-3000 HDR as light source A spectrum)	
Measurement angle ¹⁾	: 0.01 to 1,400,000 lx
Measurement angle ²⁾	: 0.25 to 35,000,000 lx
Measurement angle ³⁾	: 1 to 140,000,000 lx



System Diagram

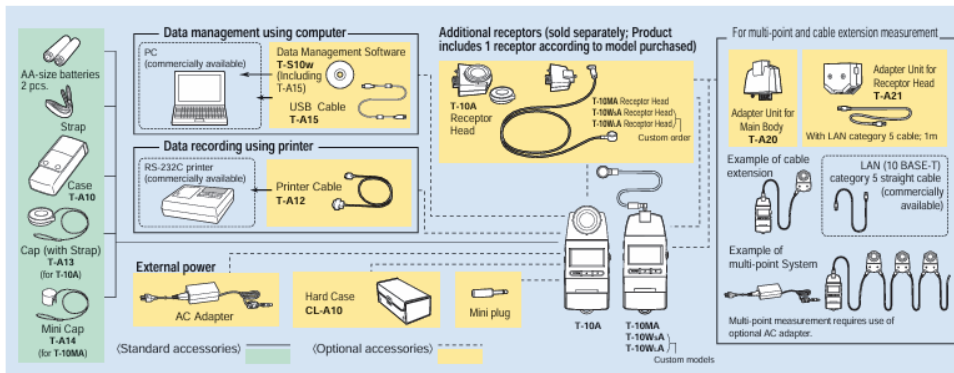

Main Specifications of T-10A

Model	Illuminance Meter T-10A (Standard receptor head)	Illuminance Meter T-10MA (Mini receptor head)	Illuminance Meter T-10W-A (Waterproof mini receptor head)	Illuminance Meter T-10W-A (Waterproof mini receptor head)
Type	Multi-function digital illuminance meter with detachable receptor head (Multi-point measurements of 2 to 30 points is possible)			
Illuminance meter class	Conforms to requirements for Class AA of JIS C 1609-1: 2006 "Illuminance meters Part 1: General measuring instruments" Conforms to DIN 5032 Part 7 Class B		Conforms to requirements for special illuminance meters of JIS C 1609-1: 2006 *1	
Receptor	Silicon photocell			
Relative spectral responsivity	Within 6% (f_{λ}) of the CIE spectral luminous efficiency $V(\lambda)$			
Cosine correction characteristics (#)	Within 3%		Within 10%	
Measuring range	Auto range (5 manual ranges at the time of analog output)			
Measuring function	Illuminance (lx), illuminance difference (lx), illuminance ratio (%), integrated illuminance (lx·h), integration time (h), average illuminance (lx)			
Measuring range	Illuminance: 0.01 to 299,900 lx; 0.001 to 29,990 fcd	Illuminance: 0.01 to 299,900 lx; 0.001 to 29,990 fcd	Illuminance: 1.00 to 299,900 lx; 0.1 to 29,990 fcd *2	Illuminance: 1.00 to 299,900 lx; 0.1 to 29,990 fcd
Integrated illuminance	0.01 to 999,900 x 10 ⁻³ lx·h 0.001 to 99,990 x 10 ⁻³ fcd·h / 0.001 to 9999 h			
User calibration function	CCF (Color Correction Factor) setting function: Measurement value x 0.500 to 2.000			
Linearity	±2% ±1 digit of displayed value			
Temperature/humidity drift	Within ±3%			
Measurement speed	2 times/sec. (continuous measurement with 1 receptor head)			
Computer interface	USB			
Printer output	RS-232C			
Analog output	1 mV/digit, 3 V at maximum reading; Output impedance: 10 KΩ; 90% response time: 28 ms			
Display	3 or 4 Significant-digit LCD with backlight illumination (Automatic illumination)			
Power	2 AA-size batteries/ AC adapter (optional)			
Battery performance	72 hours or longer (when alkaline batteries are used) in continuous measurement			
Operation temperature/humidity range	-10 to 40°C, relative humidity 85% or less (at 35°C) with no condensation		5 to 40°C, relative humidity of 85% or less (at 35°C) with no condensation	
Storage temperature/humidity range	-20 to 55°C, relative humidity 85% or less (at 35°C) with no condensation		0 to 55°C, relative humidity of 85% or less (at 35°C) with no condensation	
Size (W x D x H)	69 x 174 x 35 mm	Main body: 69 x 161.5 x 30 mm Receptor: Ø16.5 x 13.8 mm		
Cord length	-	1 m	5 m	10 m
Weight (without battery)	200 g (7.0 oz.)	205 g	260 g (Receptor head only: 120 g)	340 g (Receptor head only: 200 g)

*1 Conforms to requirements for Class AA of JIS C 1609-1: 2006 for all items except cosine response (f_λ).
 *2 Although measurements below 1.00 lx are possible, they may not be stable due to the effects of electrical noise.
 <Notes regarding mini receptors and waterproof mini receptors>
 * Do not touch the cable during measurements. Doing so may result in unstable measurement values.
 * Secure the cable during measurements. Failure to do so may result in unstable measurement values.
 • KONICA MINOLTA, the Konica Minolta logo and symbol mark, and "Giving Shape to Ideas" are registered trademarks or trademarks of KONICA MINOLTA, INC.
 • Windows® and Excel® are trademarks of Microsoft Corporation in the USA and other countries.
 • The specifications and appearance shown herein are subject to change without notice.
 • Screens shown are for illustration purpose only.
 • Some lamp control methods may make accurate measurements difficult. For details, please contact your nearest Konica Minolta sales office or dealer.

Dimensions (Units: mm)

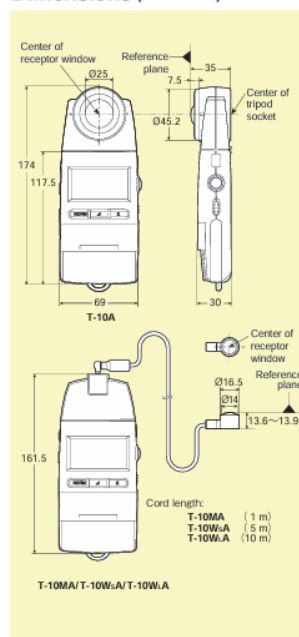

SAFETY PRECAUTIONS

For correct use and for your safety, be sure to read the instruction manual before using the instrument.

- Always connect the instrument to the specified power supply voltage. Improper connection may cause a fire or electric shock.
- Be sure to use the specified batteries. Using improper batteries may cause a fire or electric shock.

ISO Certifications of KONICA MINOLTA, Inc., Sakai Site

ISO 9001
Design, development, manufacture/
manufacturing management, calibration and
service of measuring instruments

ISO 14001
Design, development,
manufacture, service and calibration of
measuring instruments

CONTACT US - Global Network
<https://www.konicaminolta.com/instruments/network/index.html>

Appendix 15. Konica Minolta CL-500A Illuminance Spectrophotometer Brochure.



KONICA MINOLTA

Ideal for evaluating CRI
(color rendering index)

Illuminance Spectrophotometer CL-500A

*For evaluation of high-class next-generation lamps
such as LED illumination and EL illumination
Now scotopic illuminance can also be measured.*

Both instrument and included software have been upgraded to provide improved instrument operation and software display of MacAdam SDCM levels.

The first illuminance spectrophotometer that conforms to both DIN and JIS standards. Includes convenient, easy-to-use PC software.

The Standard in Measuring Color & Light

Giving Shape to Ideas

Use the CL-500A for CRI (color rendering index) evaluation!

Handheld illuminance spectrophotometer conforms to both DIN and JIS standards.

The CL-500A conforms to DIN 5032 Part 7 Class B and JIS C 1609-1:2006 General Class AA, making it the first compact, lightweight, handheld illuminance spectrophotometer to conform to both DIN and JIS standards.

Compact, lightweight, handheld

The CL-500A weighs only 350g, making it easy to take along or to hold in your hand for measurements.



All-in-one type. No PC needed.

The CL-500A can be used by itself for measuring CRI or color temperature of lamps. In addition, the spectral irradiance waveform and peak wavelength can also be checked.

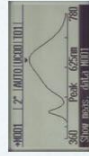

Measurement of spectral irradiance (w/m²) at each wavelength.

The spectral irradiance can be measured at 1-nm pitch from 360 to 780 nm, so the CL-500A can be used not only for measuring the color of light but also for measuring photosynthetic photon flux density (PPFD).

High-speed measurement possible

Using the 'SDK' high-speed measurements at 5 frames/sec, can be taken.

*Software Development Kit

Measures and displays both the general color-rendering index Ra as well as the special color-rendering indexes R1 to R15.

The special color-rendering indexes R1 to R15 can be displayed, so the color-rendering index for a specific color such as for R9 (red) can be easily measured and displayed.

Illuminance measurements (JIS AA Class) also possible

Scotopic illuminance can also be measured.

Most conventional illuminance meters can only measure photopic illuminance, but the CL-500A can also measure "scotopic (dark-adapted) illuminance both with the instrument alone and when used with the included software. Plus, the S/P ratio of scotopic illuminance and photopic illuminance can also be displayed.

*Scotopic vision vs. photopic vision
The sensitivity of the human eye under low-light conditions is different than that under bright conditions. The CL-500A can measure "scotopic (dark-adapted) vision", with a sensitivity peak wavelength which is shifted toward the shorter wavelengths compared to vision under bright conditions, which is termed "photopic vision". The respective spectral luminous efficiency curves for each type of vision are shown at right.

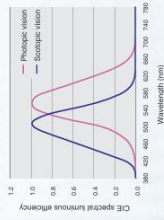

Convenient measurement functions

- 1) Continuous measurement mode : For monitoring changes in illuminance levels or spectral power distribution.
- 2) Display of the average of multiple measurements : Useful for evaluation of projectors, etc.
- 3) Delayed-measurement function : The CL-500A can be set to wait for a specific time after the measuring operation is completed, and then the measurement is taken to make sure that light reflected from you or your clothes do not affect measurements.
- 4) Display of data at specific wavelength: Allows monitoring of spectral irradiance at a specific wavelength.

Main applications:

- Measurement and evaluation of the illuminance, color temperature, and color-rendering index of indoor illumination sources such as LEDs, organic EL sources, fluorescent lamps, etc.
- Measurement and evaluation of the illuminance, color temperature, and color-rendering index of special illumination sources used for TV broadcasting stations, studios, stages, events, etc.
- Measurement of ambient lighting including sunlight.
- Measurement of the illumination and color temperature of various types of projectors.
- Measurement of the photosynthetic photon flux density (PPFD) of light sources used for agriculture.
- Standard instrument for illuminance meters or illuminance colorimeters.



Comprehensive software included

Data Management Software CL-S10w (Standard accessory)

Convenient, easy-to-use Excel® add-in software
 Reads measurement data from the CL-500A directly into Excel®. Further processing of data can then be performed easily using the various functions of Excel®.

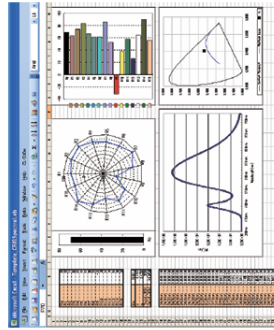

Includes Excel® add-in software as standard accessory.

Spectral irradiance waveform display
 Since peak wavelengths can be seen easily, classification and grading of light sources can be performed easily at high accuracy. In addition, numerical data at 1 nm can also be viewed in list form.

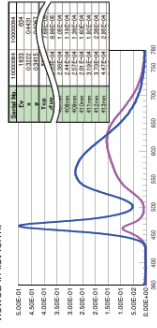

Multi-point measurement possible using multiple CL-500A units
 Data Management Software CL-S10w can be used to control up to 10 CL-500A units for multi-point measurements. Using the SDK, this can be further expanded. Please contact our sales person for further information.

Informative color-rendering index display
 Color-rendering indexes are shown visually for easy understanding. The shifts between a test light source and a standard light source can be seen at a glance, with bar graphs showing the general color-rendering index Ra (the average of special color-rendering indexes R1 to R8) and the special color-rendering indexes for a total of 15 colors (R1 to R15).

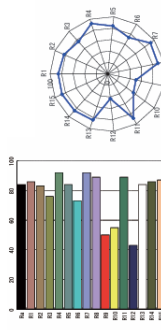

MacAdam SDCM level display

CL-S10w includes a template for expressing the chromaticity variation of illumination light sources such as LEDs or organic EL sources in terms of the MacAdam SDCM (Standard Deviation of Color Matching) step. This allows display of color differences that closely match visual judgment.

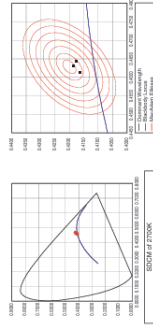

What is color-rendering property?

Colors are generally compared by arranging objects side-by-side and looking at them under natural light (sunlight).
 When comparing how lamps such as fluorescent lamps, LEDs (light emitting diodes), etc. make objects look against how natural light makes them look, how closely the appearances match is called the "color-rendering property" of the lamp. A lamp that produces a hue similar to that of natural light is said to have a good (high) color-rendering property. The color-rendering property of a lamp is expressed by the color-rendering index. The color-rendering index expresses the comparison between the light source being tested and a standard illuminant*. The maximum value is 100, with the value decreasing as the color-rendering difference increases, indicating how far the appearance under the test light source is from the natural color under sunlight.
 * Standard illuminant with the same color temperature as the light source being tested. (Light along the blackbody locus corresponds to sunlight).

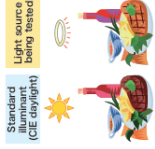

Color-rendering indexes include the general color-rendering index (Ra) and special color-rendering indexes (R1 to R15)

Test - color samples

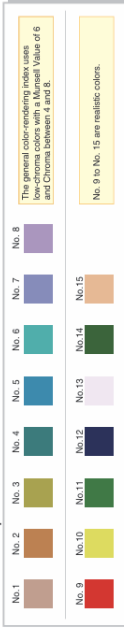

To learn more about the theory and practice of light and color measurement, please visit <https://www.konicaminolta.com/instruments/knowledge/index.html>

Konica Minolta Measurement Fundamentals

Konica Minolta's Illuminance Measurement Trio

Illuminance Spectrophotometer CL-500A Measures color-rendering properties
 Measures color-rendering properties as well as illumination. Displays spectral waveform using included CL-S10w software. Conforms to DIN and JIS standards.

Chroma Meter CL-200A Measures color temperature
 A de facto industry standard for color-temperature measurement. Can also perform illuminance measurements (JIS AA Class).
 Includes a light-receptor connectable with extension cables. Includes simple, convenient PC software as standard accessory.

Illuminance Meter T-10A Can measure PWM-controlled lighting
 Conforms to DIN Class B and JIS AA Class. Capable of accurately measuring next-generation lamps including PWM-controlled lighting.
 Multiple receptors can be used for multi-point measurement.
 A miniature receptor T-10MA is also available for measuring illuminance in narrow spaces.

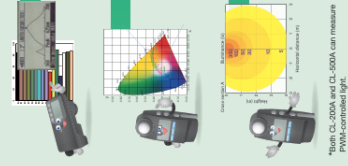

*Type CL-500A and CL-500A can measure PWM-controlled light.

System Diagram

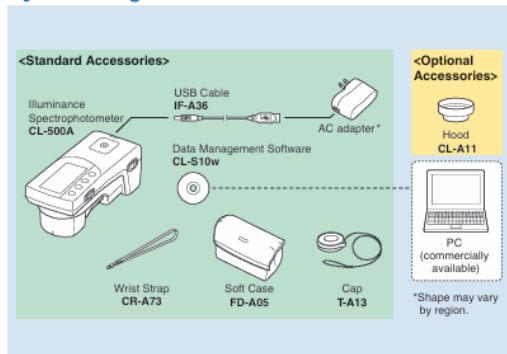

Dimensions (Units: mm)

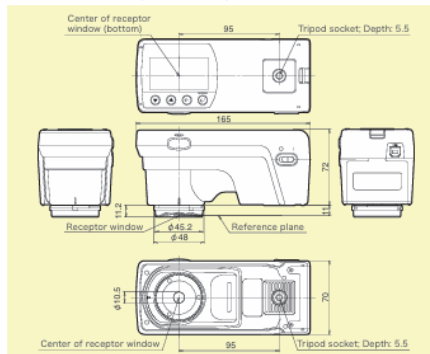

Main Specifications of CL-500A

Model	Illuminance Spectrophotometer CL-500A
Illuminance meter class	Conforms to requirements for Class AA of JIS C 1609-1:2006 *Illuminance meters Part 1, General measuring instruments** Conforms to DIN 5032 Part 7 Class B
Wavelength range	360 to 780 nm
Output wavelength pitch	1 nm
Spectral bandwidth	Approx. 10 nm (half bandwidth)
Wavelength precision	±0.3 nm (Median wavelengths of 435.8 nm, 546.1 nm, and 585.3 nm** as specified in JIS Z 8724:1997)** ¹
Measuring range	0.1 to 100,000 lx (chromaticity display requires 5 lx or more)
Accuracy** ^{1,5} (Standard Illuminant A)	E _v (Illuminance) : ±2%±1 digit of displayed value xy: ±0.0015 (10 to 100,000 lx) xy: ±0.002 (5 to 10 lx)
Repeatability (2σ)** ¹ (Standard Illuminant A)	E _v : 0.5%±1 digit xy: 0.0005 (500 to 100,000 lx) xy: 0.001 (100 to 500 lx) xy: 0.002 (30 to 100 lx) xy: 0.004 (5 to 30 lx)
Visible-region relative spectral responsivity characteristics (f _v)	Within 1.5% of spectral luminous efficiency V (λ)
Cosine correction characteristics (f _c)	E _v : Within 3%
Temperature drift (f _t)	E _v : ±3% of displayed value; xy: ±0.003
Humidity drift (f _h)	E _v : ±3% of displayed value; xy: ±0.003
Measurement time	Super Fast mode: Approx. 0.2 sec. (when connected to computer); Fast mode: Approx. 0.5 sec.; Slow mode: Approx. 2.5 sec.; Automatic exposure time setting (high accuracy) mode: Approx. 0.5 to 27 sec.
Display mode	XYZ; X ₀ Y ₀ Z ₀ ; E _v xy; E _v uv; E _v ; Dominant wavelength, Excitation purity; Correlated color temperature, duv; General color-rendering index (Ra); Special color-rendering indexes (Ri (i=1-15)); Spectral graph; Peak wavelength; λ (XYZ); λ (X ₀ Y ₀ Z ₀); λ (E _v xy); λ (E _v uv); Rank display; Scotopic illuminance; S/P ratio; Spectral irradiance
Other functions	Data memory: 100 data; User calibration function (when connected to computer); Continuous measurement (when connected to computer); Auto power off function
Display languages	English, Japanese, Chinese (Simplified)
Interface	USB 2.0
Power	Rechargeable internal lithium-ion battery (Operating time per charge: Approx. 6 hours when new); AC adapter; USB power bus
Operation temperature/humidity range	-10 to 40°C, relative humidity of 85% or less (at 35°C) with no condensation
Storage temperature/humidity range	-10 to 45°C, relative humidity of 85% or less (at 35°C) with no condensation
Size (W × D × H)	70 × 165 × 83 mm
Weight	350 g

¹ For Section 7.6.3 Response Time, when measurement speed mode is set to FAST mode.
² For 585.3 nm, evaluation performed using substitute wavelength of 587.5 nm.
³ Based on Konica Minolta test standards (change in temperature of 5°C or less after zero calibration).
⁴ Automatic exposure time setting (high accuracy) mode
⁵ Linear for E_v (Illuminance)

Main specifications of Data Management Software CL-S10w

Type	Add-in for Excel® (Excel® is required to use this add-in.)
Operating environment	One of the following environments is required for Excel® to operate. OS: Windows® 10 Pro 32bit/64bit Windows® 11 Pro OS language: English, Japanese, Simplified Chinese, Traditional Chinese Application software: Excel® 2016 32bit/64bit Excel® 2019 32bit/64bit Excel® 2021 32bit/64bit For details on system requirements for the above versions of Windows® and/or Excel®, refer to their respective specifications
Compatible instruments	CL-500A, CL-200A, CL-200* * Some functions not usable with CL-200.
Display items	Spectral irradiance (W/m ² /nm); Illuminance; general color-rendering index Ra; correlated color temperature; etc.

SAFETY PRECAUTIONS

For correct use and for your safety, be sure to read the instruction manual before using the instrument.

- Always connect the instrument to the specified power supply voltage. Improper connection may cause a fire or electric shock.

ISO Certifications of KONICA MINOLTA, Inc., Sakai Site



ISO 9001

JSA-QM41598B
Design, development, manufacture/
manufacturing management, calibration, and
service of measuring instruments



ISO 14001

JSA-E-40227
Design, development,
manufacture, service and sales
of measuring instruments

CONTACT US - Global Network

<https://www.konicaminolta.com/instruments/network/index.html>



Appendix 16. Konica Minolta LS-150 Luminance Meter Brochure.



Luminance Meter

LS-150/LS-160

4

New models with higher accuracy and comfort of use !

Luminance Meter LS-150 measures luminance from 0.001 to 999,900 cd/m^2 with 1° measuring angle.

Luminance Meter LS-160 measures luminance from 0.01 to 9,999,000 cd/m^2 with $1/3^\circ$ measuring angle.

Luminance Meter LS-160 LCD display: Absolute, Lv 113600 cd/m^2 , PERK | AUTO | U 00 | T --

The Standard in Measuring Color & Light

Giving Shape to Ideas

1 High accuracy

Conforms to DIN 5032-7 Class B (LS-150)

The LS-150 and LS-160 are highly accurate luminance meters that use a newly designed sensor with a spectral response that more closely matches the V(λ) spectral luminous efficiency function of the human eye to provide measurement results that correlate well with visual evaluation.

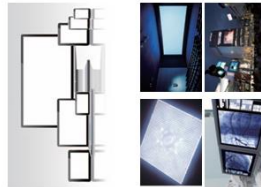
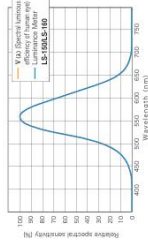
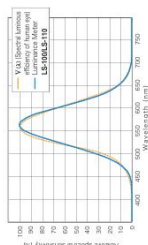

2 Incredibly easy to use

Bright viewfinder makes it easy to target desired areas of measurement subjects.

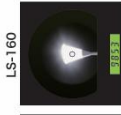

Automatic mode automatically sets the measurement time according to the brightness of the target.



Backlit display is easy to read even in dark places, and is automatically switched on during measurements.

Easy-to-hold grip. Smooth focusing during measurement.

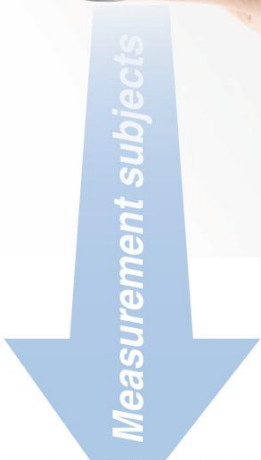

3 Numerous optional accessories

Close-up lenses
 Lineup of 4 lenses (Nos. 153, 155, 122, and 110) enable measurements of tiny areas.

Measuring area	Minimum		Maximum		Units: mm)
	width	height	width	height	
No. 153	1.0	0.4	1.3	0.5	1.5 - 215
No. 122	1.0	3.2	1.3	4.3	351 - 378
No. 155	1.6	5.2	2.7	8.6	455 - 629
No. 110	4.5	14.4	5	17.0	629 - 1012

* Measuring distance is the distance from the measuring distance reference plane.

C-mount CCD camera adapter enables the viewfinder to be monitored from a distance.



This adapter allows an industrial C-mount CCD camera to be attached to the viewfinder so that measurements including the view through the viewfinder can be monitored from a distance or recorded.

* CCD camera not included.

Illuminance adapter enables illuminance to also be measured.



Measurable illuminance range:
 • LS-150: Corresponds to 0.015 - 999,900 lx
 • LS-160: Corresponds to 0.15 - 9,999,000 lx

* This illuminance measuring range is based on the measurement mode of measurement and target data. DN or JIS standards.

4 Easy-to-understand utility software

The included software allows the meters to be controlled from a PC. Repeated interval measurements can be conducted for a specified number of times at specified intervals, measurement data can be displayed on graphs or lists, and data can be sent to spreadsheet applications.

Supported OS: Windows 7 Professional 32 bit, 64 bit
 Windows 8 Professional 32 bit, 64 bit
 Windows 10 Pro 32 bit, 64 bit

Features
Meter control
1-shot measurement
Interval measurement
Interval measurement interval: 1 sec to 300 sec
Interval measurement times: 1 to 3,000 times
Interval measurement target measurement
Setting of meter settings
Setting of target data
User calibration
Target data
Setting of target data
Data list
Download of target data from PC to meter
Download of measurement and target data of measurement and target data
Test input: Save/Save in CSV format; copying of file from respondent
External I/O



Main Specifications

Model	LS-150	LS-160
Measuring angle	1°	1 / 3°
Optical system	SLR viewing system, f = 85 mm F2.8	
Angle of view	9° (with diopter adjustment)	
Relative spectral responsivity	Closely matches spectral luminous efficiency (V (λ))	
Applicable standard	DIN 5032-7 Class B compliant	(N/A)
Minimum measuring area (diameter)	14.4 mm (1.3 mm when close-up lens is used)	4.5 mm (0.4 mm when close-up lens is used)
Minimum measuring distance (From the measuring distance reference plane)	1,012 mm (213 mm when close-up lens is used)	
Measurement mode	Instantaneous value, maximum/minimum value, luminance difference (Δ)/luminance ratio (%)	
Measurement time	AUTO: 0.7 to 4.3 seconds Manual: 0.7 to 7.1 seconds	
Luminance unit	cd/m ² or fL	
Luminance range	0.001 to 999,900 cd/m ²	0.01 to 9,999,000 cd/m ²
Accuracy*1	±2% ± 2 digits (1 cd/m ² or less) ±2% ± 1 digit (1 cd/m ² or more)	±2% ± 2 digits (10 cd/m ² or less) ±2% ± 1 digit (10 cd/m ² or more)
Repeatability*1	0.2% ± 1 digit	
Calibration standard	Konica Minolta standard/user-specified standard switchable	
User calibration channels	10 channels	
Data memory	1,000 data	
External display (Number of significant digits)	4 digits (Max.)	
Internal display (Number of significant digits)	4 digits (Max.)	
Interface	USB2.0	
Power	AA-size batteries (x2), USB bus power, or optional AC adapter	
Current consumption	When viewfinder display is lit: 70 mA average	
Operation temperature/humidity range	0 to 40°C, relative humidity of 85% or less (at 35°C)	
Storage temperature/humidity range	0 to 45°C, relative humidity of 85% or less (at 35°C)	
Size	71x214x154 mm	
Weight	850 g (without batteries)	
Standard accessories	Lens Cap Eyepiece ND Filter Eyepiece Cap AA-size batteries (x2) Hard Case CS-A12 Wrist Strap CS-A13 USB Cable T-A15 Data Management Software CS-S20	
Optional accessories	Close-Up Lens No. 153/135/122/110 CCD Camera Adapter CS-A14 Illuminance Adapter CS-A15 AC Adapter AC-A305J/L/M	

*1 Standard Illuminant A; Standard measurement distance; Measurement time setting: Auto

- KONICA MINOLTA, the Konica Minolta logo and symbol mark, and "Giving Shape to ideas" are registered trademarks or trademarks of KONICA MINOLTA, INC.
- Displays shown are for illustration purpose only.
- The specifications and appearance shown herein are subject to change without notice.
- Other company names and product names used herein are trademarks or registered trademarks of their respective companies.

SAFETY PRECAUTIONS



For correct use and for your safety, be sure to read the instruction manual before using the instrument.

● Be sure to use the specified power supply voltage. Improper connection may cause a fire or electric shock.



Certificate No. JQA-DMM15188
Registration Date: October 26, 2018
KONICA MINOLTA, Inc., Sakai Site
Product design, manufacture/manufacturing management, calibration, and service



Certificate No. JSA-E-85227
Registration Date: March 12, 1997
KONICA MINOLTA, Inc., Sakai Site

System Diagram

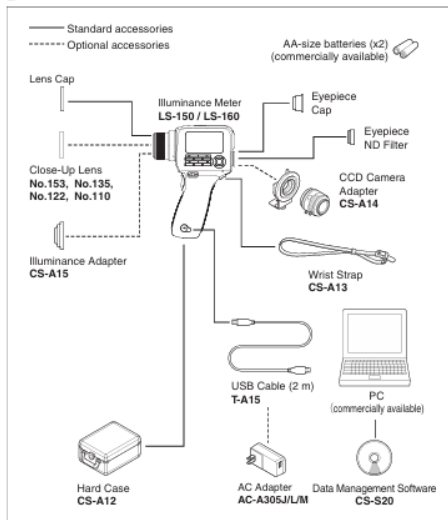

Dimensions (Units:mm)

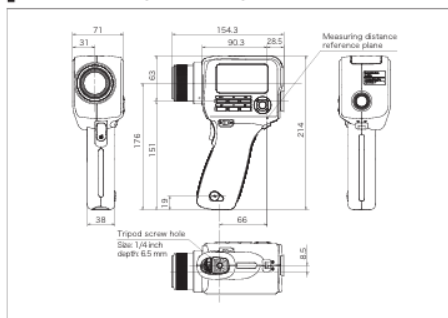

KONICA MINOLTA, INC.
Konica Minolta Sensing Americas, Inc.
Konica Minolta Sensing Europe B.V.

Osaka, Japan
New Jersey, U.S.A.
European Headquarter /BENELUX
German Office
French Office
UK Office
Italian Office
Swiss Office
Nordic Office
Polish Office
Turkish Office
SE Sales Division
Beijing Office
Guangzhou Office
Chongqing Office
Qingdao Office
Wuhan Office

Konica Minolta (CHINA) Investment Ltd.
Beijing Office
Guangzhou Office
Chongqing Office
Qingdao Office
Wuhan Office

Konica Minolta Sensing Singapore Pte Ltd.
Konica Minolta Sensing Korea Co., Ltd.
Addresses and telephonenumber numbers are subject to change without notice. For the latest contact information, please refer to the KONICA MINOLTA Worldwide Offices web page :

Phone : 888-473-2656 (in USA), 201-236-4300 (outside USA)
Nieuwegein, Netherlands
München, Germany
Ruisy CDG, France
Warrington, United Kingdom
Cinisello Balsamo, Italy
Dietikon, Switzerland
Västra Frölunda, Sweden
Wroclaw, Poland
Istanbul, Turkey
Shanghai, China
Beijing, China
Guangdong, China
Chongqing, China
Shandong, China
Hubel, China
Singapore
Goyang-si, Korea

Fax : 201-785-2482
+31 (0) 30 24 81 211
+49 (0) 89 4357 158 99
+33 (0) 1 80 11 10 82
+44 (0) 1925 711143
+39 02849488.30
+41 (0) 43 322-9809
+48 (0) 71 734 52 10
+90 (0) 212-253 49 69
+86-(0)21-5489 0005
+86-(0)10-8522 1241
+86-(0)20-3626 4223
+86-(0)23-6773 4799
+86-(0)532-8079 1873
+86-(0)27-8544 9991
+65 6560-9721
+82(0)31-995-6511

<https://konicaminolta.com/instruments/network>

Appendix 17. Visual Performance Task Data Analysis Process.

Classification Tree - Here we used Exhaustive Chaid to add in potential variables that could have affected build time

We see that Sleep had an effect . Greater than 7 hours resulted in a faster build time, Less than 7 hours resulted in a slower build time

Sleep came out as most important, then group in the decision tree model.

Model Summary

Specifications	Growing Method	EXHAUSTIVE CHAID
	Dependent Variable	Build_Time
	Independent Variables	Daylight, Gender, Vision, Illuminance, CCT, Group, Sleep
	Validation	None
	Maximum Tree Depth	5
	Minimum Cases in Parent Node	10
	Minimum Cases in Child Node	5
Results	Independent Variables Included	Sleep, Group, Daylight, CCT
	Number of Nodes	9
	Number of Terminal Nodes	5
	Depth	4

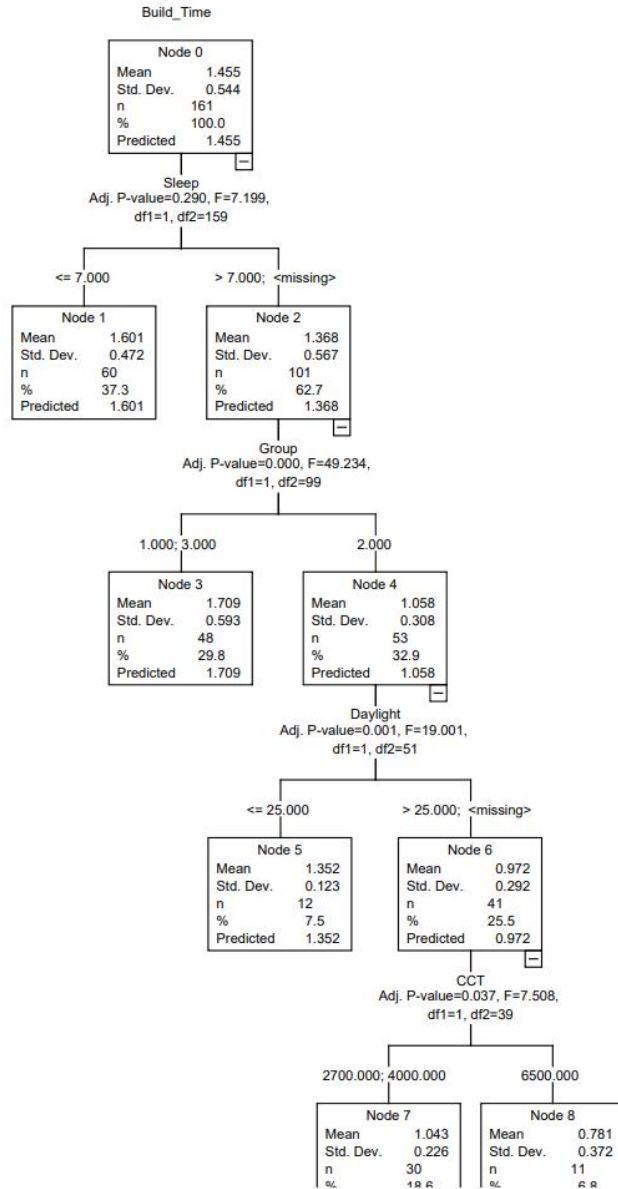

\hat{y}	1.043	\hat{y}	0.781
Predicted	1.043	Predicted	0.781

Gain Summary for Nodes

Node	N	Percent	Mean
3	48	29.8%	1.7092
1	60	37.3%	1.6010
5	12	7.5%	1.3517
7	30	18.6%	1.0427
8	11	6.8%	.7809

Growing Method: EXHAUSTIVE CHAID
 Dependent Variable: Build_Time

Risk

Estimate	Std. Error
.203	.041

Growing Method:
 EXHAUSTIVE CHAID
 Dependent Variable:
 Build_Time

Univariate Analysis of Variance

Here we discretized the sleep factor and the daylight factor 1 = less than 7 hours of sleep, 2 = > 7 hours sleep for daylight, 1 = less than 30 minutes of daylight, 2 = more than 30 mins of daylight

Between-Subjects Factors

	N	
Group	1.00	23
	2.00	22
	3.00	21
Illuminance	150.00	30
	450.00	11
	750.00	25
CCT	2700.00	6
	4000.00	38
	6500.00	22
Gender	1.00	33
	2.00	33
Sleep_Factor	1.00	29
	2.00	37
Daylight_Factor	1.00	45
	2.00	21

Tests of Between-Subjects Effects

Dependent Variable: Build_Time

Source	Type III Sum of Squares	df	Mean Square	F	Sig.
Corrected Model	5.043 ^a	9	.560	3.528	.002
Intercept	46.479	1	46.479	292.664	<.001
Group	1.141	2	.570	3.591	.034
Illuminance	.750	2	.375	2.362	.104
CCT	.111	2	.055	.349	.707
Gender	.023	1	.023	.147	.703
Sleep_Factor	.775	1	.775	4.877	.031
Daylight_Factor	.049	1	.049	.311	.579
Error	8.894	56	.159		
Total	145.546	66			
Corrected Total	13.937	65			

a. R Squared = .362 (Adjusted R Squared = .259)

The results of the ANOVA with main effects only show that group and sleep are important

Between-Subjects Factors

		N
Group	1.00	23
	2.00	22
	3.00	21
Illuminance	150.00	30
	450.00	11
	750.00	25
CCT	2700.00	6
	4000.00	38
	6500.00	22
Gender	1.00	33
	2.00	33
Sleep_Factor	1.00	29
	2.00	37
Daylight_Factor	1.00	45
	2.00	21

Tests of Between-Subjects Effects

Dependent Variable: Build_Time

Source	Type III Sum of Squares	df	Mean Square	F	Sig.
Corrected Model	5.445 ^a	11	.495	3.148	.002
Intercept	46.830	1	46.830	297.807	<.001
Group	1.043	2	.521	3.315	.044
Illuminance	.679	2	.340	2.160	.125
CCT	.061	2	.031	.195	.823
Gender	.034	1	.034	.215	.645
Sleep_Factor	.781	1	.781	4.970	.030
Daylight_Factor	.111	1	.111	.708	.404
Group * Sleep_Factor	.402	2	.201	1.279	.287
Error	8.491	54	.157		
Total	145.546	66			
Corrected Total	13.937	65			

a. R Squared = .391 (Adjusted R Squared = .267)

No interaction between group and sleep

Profile Plots - more sleep faster build time, less sleep slower build time

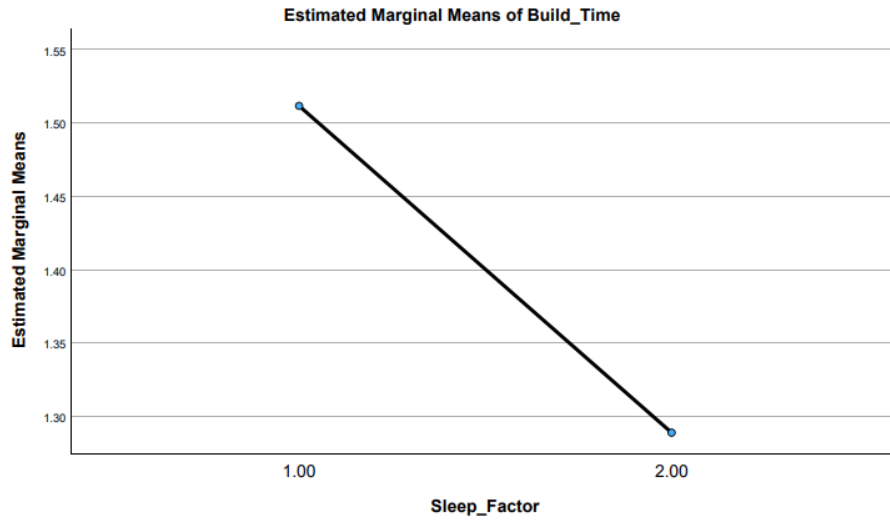

Between-Subjects Factors

		N
Group	1.00	23
	2.00	22
	3.00	21
Illuminance	150.00	30
	450.00	11
	750.00	25
CCT	2700.00	6
	4000.00	38
	6500.00	22
Gender	1.00	33
	2.00	33
Sleep_Factor	1.00	29
	2.00	37
Daylight_Factor	1.00	45
	2.00	21

Profile Plots

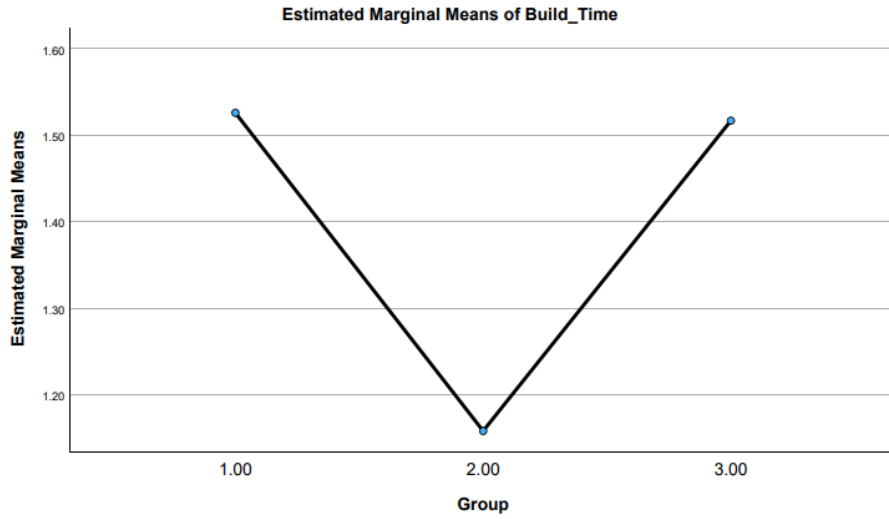

Means

Report

Build_Time			
Group	Mean	N	Std. Deviation
1.00	1.6013	60	.50066
2.00	1.0583	53	.30754
3.00	1.7088	48	.56311
Total	1.4546	161	.54387

Build_Time by Group

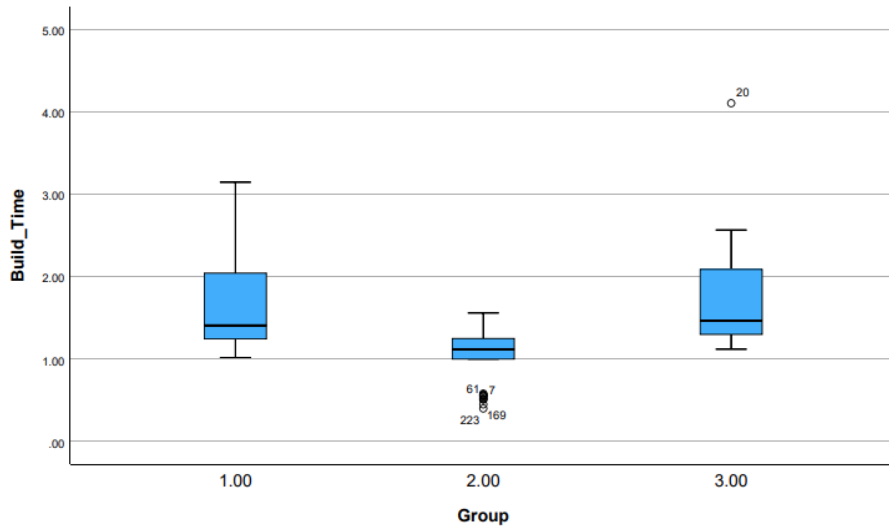

Group*Sleep_Factor

Build_Time

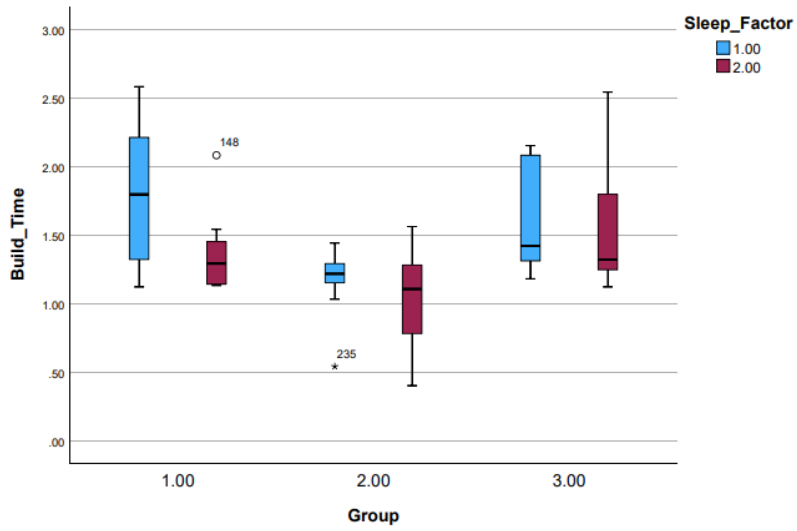

Univariate Analysis of Variance - Just used group and sleep factor - group explained

Between-Subjects Factors

		N
Group	1.00	23
	2.00	22
	3.00	21
Sleep_Factor	1.00	29
	2.00	37

Tests of Between-Subjects Effects

Dependent Variable: Build_Time

Source	Type III Sum of Squares	df	Mean Square	F	Sig.
Corrected Model	4.557 ^a	5	.911	5.831	<.001
Intercept	132.138	1	132.138	845.283	<.001
Group	3.405	2	1.702	10.890	<.001
Sleep_Factor	.826	1	.826	5.284	.025
Group * Sleep_Factor	.421	2	.211	1.347	.268
Error	9.379	60	.156		
Total	145.546	66			
Corrected Total	13.937	65			

a. R Squared = .327 (Adjusted R Squared = .271)

Estimated Marginal Means

1. Group

Dependent Variable: Build_Time

Group	Mean	Std. Error	95% Confidence Interval	
			Lower Bound	Upper Bound
1.00	1.579	.083	1.412	1.745
2.00	1.104	.085	.934	1.273
3.00	1.598	.087	1.424	1.773

2. Sleep_Factor

Dependent Variable: Build_Time

Sleep_Factor	Mean	Std. Error	95% Confidence Interval	
			Lower Bound	Upper Bound
1.00	1.540	.074	1.393	1.687
2.00	1.314	.065	1.184	1.444

3. Group * Sleep_Factor

Dependent Variable: Build_Time

Group	Sleep_Factor	Mean	Std. Error	95% Confidence Interval	
				Lower Bound	Upper Bound
1.00	1.00	1.804	.125	1.554	2.054
	2.00	1.353	.110	1.134	1.572
2.00	1.00	1.164	.125	.914	1.414
	2.00	1.043	.114	.815	1.272
3.00	1.00	1.651	.132	1.387	1.915
	2.00	1.546	.114	1.318	1.774

Post Hoc Tests

Group

Multiple Comparisons

Dependent Variable: Build_Time

Tukey HSD

(I) Group	(J) Group	Mean Difference (I-J)	Std. Error	Sig.	95% Confidence Interval	
					Lower Bound	Upper Bound
1.00	2.00	.4509*	.11791	<.001	.1676	.7343
	3.00	-.0418	.11933	.935	-.3286	.2450
2.00	1.00	-.4509*	.11791	<.001	-.7343	-.1676
	3.00	-.4928*	.12062	<.001	-.7827	-.2029
3.00	1.00	.0418	.11933	.935	-.2450	.3286
	2.00	.4928*	.12062	<.001	.2029	.7827

Based on observed means.

The error term is Mean Square(Error) = .156.

*. The mean difference is significant at the 0.05 level.

Tukey Post Hoc shows group mean performance

Build_Time

Tukey HSD^{a,b,c}

Group	N	Subset	
		1	2
2.00	22	1.0982	
1.00	23		1.5491
3.00	21		1.5910
Sig.		1.000	.935

Means for groups in homogeneous subsets are displayed.
 Based on observed means.
 The error term is Mean Square(Error) = .156.

- a. Uses Harmonic Mean Sample Size = 21.970.
- b. The group sizes are unequal. The harmonic mean of the group sizes is used. Type I error levels are not guaranteed.
- c. Alpha = 0.05.

Profile Plots

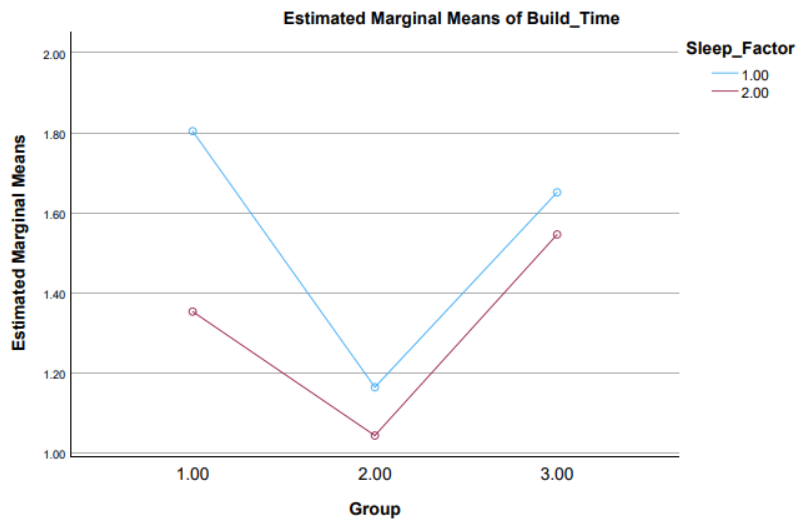

Appendix 18. Light Preference Data Analysis Process.

Profile Plots

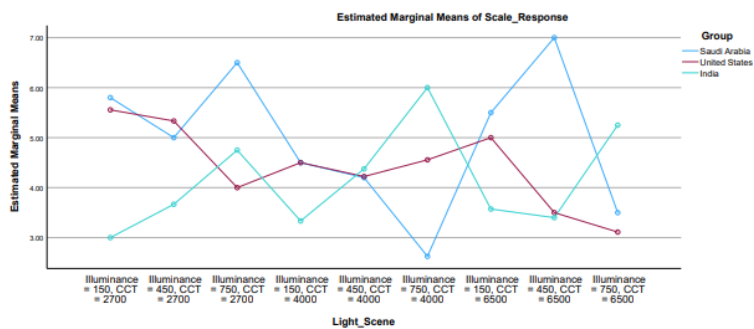

Univariate Analysis of Variance

Notes

Output Created	15-MAR-2025 12:29:41	
Comments		
Input	Data	C: \Users\weba3148\OneDrive - UCB-O365\UCB\Desktop\Omar Data\Omar Preference Data.sav
	Active Dataset	DataSet1
	Filter	Preference = 4 (FILTER)
	Weight	<none>
	Split File	<none>
	N of Rows in Working Data File	322
Missing Value Handling	Definition of Missing	User-defined missing values are treated as missing.
	Cases Used	Statistics are based on all cases with valid data for all variables in the model.

Notes

Syntax	<pre> UNIANOVA Scale_Response BY Group Illuminance CCT /METHOD=SSTYPE(3) /INTERCEPT=INCLUDE /POSTHOC=Group Illuminance CCT(TUKEY) /PLOT=PROFILE (Illuminance*CCT*Group) TYPE=LINE ERRORBAR=NO MEANREFERENCE=NO YAXIS=AUTO /EMMEANS=TABLES (Group*Illuminance*CCT) COMPARE(Group) ADJ (BONFERRONI) /EMMEANS=TABLES (Group*Illuminance*CCT) COMPARE(Illuminance) ADJ(BONFERRONI) /EMMEANS=TABLES (Group*Illuminance*CCT) COMPARE(CCT) ADJ (BONFERRONI) /PRINT DESCRIPTIVE /CRITERIA=ALPHA(.05) /DESIGN=Group Illuminance CCT Group*Illuminance Group*CCT Illuminance*CCT Group*Illuminance*CCT. </pre>	
Resources	Processor Time	00:00:00.30
	Elapsed Time	00:00:00.26

Between-Subjects Factors

	Value Label	N
Group	1.00 Saudi Arabia	120
	2.00 United States	106
	3.00 India	96
Illuminance	150.00	114
	450.00	100
	750.00	108
CCT	2700.00	94
	4000.00	130
	6500.00	98

Descriptive Statistics

Dependent Variable: Scale_Response

Group	Illuminance	CCT	Mean	Std. Deviation	N
Saudi Arabia	150.00	2700.00	5.8000	1.76516	20
		4000.00	4.5000	2.01311	20
		6500.00	5.5000	1.73205	4
		Total	5.1818	1.94425	44
	450.00	2700.00	5.0000	2.00000	12
		4000.00	4.2000	1.64157	20
		6500.00	7.0000	.00000	4
		Total	4.7778	1.86871	36
	750.00	2700.00	6.5000	.57735	4
		4000.00	2.6250	1.54380	16
		6500.00	3.5000	2.01311	20
		Total	3.4500	2.03747	40
	Total	2700.00	5.6111	1.79329	36
4000.00		3.8571	1.90147	56	
6500.00		4.2857	2.22539	28	
Total		4.4833	2.07823	120	
United States	150.00	2700.00	5.5556	.98352	18
		4000.00	4.5000	1.56670	12
		6500.00	5.0000	1.15470	4
		Total	5.1176	1.29719	34
	450.00	2700.00	5.3333	1.36626	6
		4000.00	4.2222	1.66470	18
		6500.00	3.5000	.53452	8
		Total	4.2500	1.50269	32
	750.00	2700.00	4.0000	1.15470	4
		4000.00	4.5556	1.68810	18
		6500.00	3.1111	.75840	18
		Total	3.8500	1.44204	40
	Total	2700.00	5.2857	1.18187	28
4000.00		4.4167	1.62210	48	
6500.00		3.4667	.97320	30	
Total		4.3774	1.50208	106	
India	150.00	2700.00	3.0000	1.46059	16
		4000.00	3.3333	1.36626	6
		6500.00	3.5714	1.82775	14
	Total	3.2778	1.57863	36	
	450.00	2700.00	3.6667	1.36626	6
		4000.00	4.3750	1.36015	16

Descriptive Statistics

Dependent Variable: Scale_Response

Group	Illuminance	CCT	Mean	Std. Deviation	N
		6500.00	3.4000	1.07497	10
		Total	3.9375	1.31830	32
	750.00	2700.00	4.7500	1.16496	8
		4000.00	6.0000	1.15470	4
		6500.00	5.2500	1.00000	16
		Total	5.2143	1.10075	28
	Total	2700.00	3.6000	1.52225	30
		4000.00	4.3846	1.52517	26
		6500.00	4.2000	1.58842	40
		Total	4.0625	1.56819	96
Total	150.00	2700.00	4.8889	1.89006	54
		4000.00	4.3158	1.80248	38
		6500.00	4.1818	1.84226	22
		Total	4.5614	1.86270	114
	450.00	2700.00	4.7500	1.77544	24
		4000.00	4.2593	1.54413	54
		6500.00	4.0909	1.60087	22
		Total	4.3400	1.61571	100
	750.00	2700.00	5.0000	1.36626	16
		4000.00	3.8947	1.94227	38
		6500.00	3.8889	1.65594	54
		Total	4.0556	1.75528	108
	Total	2700.00	4.8723	1.76729	94
		4000.00	4.1692	1.73937	130
		6500.00	4.0000	1.67455	98
		Total	4.3230	1.76007	322

Tests of Between-Subjects Effects

Dependent Variable: Scale_Response

Source	Type III Sum of Squares	df	Mean Square	F	Sig.
Corrected Model	311.404 ^a	26	11.977	5.173	<.001
Intercept	4546.450	1	4546.450	1963.675	<.001
Group	25.313	2	12.656	5.467	.005
Illuminance	.115	2	.058	.025	.975
CCT	13.943	2	6.972	3.011	.051
Group * Illuminance	88.073	4	22.018	9.510	<.001
Group * CCT	71.535	4	17.884	7.724	<.001
Illuminance * CCT	12.056	4	3.014	1.302	.269
Group * Illuminance * CCT	48.144	8	6.018	2.599	.009
Error	683.006	295	2.315		
Total	7012.000	322			
Corrected Total	994.410	321			

a. R Squared = .313 (Adjusted R Squared = .253)

Estimated Marginal Means

1. Group * Illuminance * CCT

Estimates

Dependent Variable: Scale_Response

Group	Illuminance	CCT	Mean	Std. Error	95% Confidence Interval	
					Lower Bound	Upper Bound
Saudi Arabia	150.00	2700.00	5.800	.340	5.130	6.470
		4000.00	4.500	.340	3.830	5.170
		6500.00	5.500	.761	4.003	6.997
	450.00	2700.00	5.000	.439	4.136	5.864
		4000.00	4.200	.340	3.530	4.870
		6500.00	7.000	.761	5.503	8.497
	750.00	2700.00	6.500	.761	5.003	7.997
		4000.00	2.625	.380	1.876	3.374
		6500.00	3.500	.340	2.830	4.170
United States	150.00	2700.00	5.556	.359	4.850	6.261
		4000.00	4.500	.439	3.636	5.364
		6500.00	5.000	.761	3.503	6.497
	450.00	2700.00	5.333	.621	4.111	6.556
		4000.00	4.222	.359	3.516	4.928
		6500.00	3.500	.538	2.441	4.559
	750.00	2700.00	4.000	.761	2.503	5.497
		4000.00	4.556	.359	3.850	5.261
		6500.00	3.111	.359	2.405	3.817
India	150.00	2700.00	3.000	.380	2.251	3.749
		4000.00	3.333	.621	2.111	4.556
		6500.00	3.571	.407	2.771	4.372
	450.00	2700.00	3.667	.621	2.444	4.889
		4000.00	4.375	.380	3.626	5.124
		6500.00	3.400	.481	2.453	4.347
	750.00	2700.00	4.750	.538	3.691	5.809
		4000.00	6.000	.761	4.503	7.497
		6500.00	5.250	.380	4.501	5.999

Pairwise Comparisons

Dependent Variable: Scale_Response

Illuminance	CCT	(I) Group	(J) Group	Mean Difference (I-J)	Std. Error	Sig. ^b
150.00	2700.00	Saudi Arabia	United States	.244	.494	1.000
			India	2.800*	.510	<.001
		United States	Saudi Arabia	-.244	.494	1.000
			India	2.556*	.523	<.001
		India	Saudi Arabia	-2.800*	.510	<.001
			United States	-2.556*	.523	<.001
	4000.00	Saudi Arabia	United States	8.882E-16	.556	1.000
			India	1.167	.708	.302
		United States	Saudi Arabia	-8.882E-16	.556	1.000
			India	1.167	.761	.379
		India	Saudi Arabia	-1.167	.708	.302
			United States	-1.167	.761	.379
6500.00	Saudi Arabia	United States	.500	1.076	1.000	
		India	1.929	.863	.078	
	United States	Saudi Arabia	-.500	1.076	1.000	
		India	1.429	.863	.296	
	India	Saudi Arabia	-1.929	.863	.078	
		United States	-1.429	.863	.296	
450.00	2700.00	Saudi Arabia	United States	-.333	.761	1.000
			India	1.333	.761	.242
		United States	Saudi Arabia	.333	.761	1.000
			India	1.667	.878	.176
		India	Saudi Arabia	-1.333	.761	.242
			United States	-1.667	.878	.176
	4000.00	Saudi Arabia	United States	-.022	.494	1.000
			India	-.175	.510	1.000
		United States	Saudi Arabia	.022	.494	1.000
			India	-.153	.523	1.000
		India	Saudi Arabia	.175	.510	1.000
			United States	.153	.523	1.000
	6500.00	Saudi Arabia	United States	3.500*	.932	<.001
			India	3.600*	.900	<.001
		United States	Saudi Arabia	-3.500*	.932	<.001
			India	.100	.722	1.000
		India	Saudi Arabia	-3.600*	.900	<.001
			United States	-.100	.722	1.000

Pairwise Comparisons

Dependent Variable: Scale_Response

Illuminance	CCT	(I) Group	(J) Group	95% Confidence Interval for Difference ^b	
				Lower Bound	Upper Bound
150.00	2700.00	Saudi Arabia	United States	-.946	1.435
			India	1.571	4.029
		United States	Saudi Arabia	-1.435	.946
			India	1.297	3.814
		India	Saudi Arabia	-4.029	-1.571
			United States	-3.814	-1.297
	4000.00	Saudi Arabia	United States	-1.338	1.338
			India	-.539	2.872
		United States	Saudi Arabia	-1.338	1.338
			India	-.665	2.998
		India	Saudi Arabia	-2.872	.539
			United States	-2.998	.665
6500.00	Saudi Arabia	United States	-2.091	3.091	
		India	-.148	4.006	
	United States	Saudi Arabia	-3.091	2.091	
		India	-.648	3.506	
	India	Saudi Arabia	-4.006	.148	
		United States	-3.506	.648	
450.00	2700.00	Saudi Arabia	United States	-2.165	1.498
			India	-.498	3.165
		United States	Saudi Arabia	-1.498	2.165
			India	-.449	3.782
		India	Saudi Arabia	-3.165	.498
			United States	-3.782	.449
	4000.00	Saudi Arabia	United States	-1.212	1.168
			India	-1.404	1.054
		United States	Saudi Arabia	-1.168	1.212
			India	-1.412	1.106
		India	Saudi Arabia	-1.054	1.404
			United States	-1.106	1.412
	6500.00	Saudi Arabia	United States	1.257	5.743
			India	1.433	5.767
		United States	Saudi Arabia	-5.743	-1.257
			India	-1.638	1.838
		India	Saudi Arabia	-5.767	-1.433
			United States	-1.838	1.638

Pairwise Comparisons

Dependent Variable: Scale_Response

Illuminance	CCT	(I) Group	(J) Group	Mean Difference (I-J)	Std. Error	Sig. ^b
750.00	2700.00	Saudi Arabia	United States	2.500	1.076	.062
			India	1.750	.932	.184
		United States	Saudi Arabia	-2.500	1.076	.062
			India	-.750	.932	1.000
		India	Saudi Arabia	-1.750	.932	.184
			United States	.750	.932	1.000
	4000.00	Saudi Arabia	United States	-1.931*	.523	<.001
			India	-3.375*	.851	<.001
		United States	Saudi Arabia	1.931*	.523	<.001
			India	-1.444	.841	.261
		India	Saudi Arabia	3.375*	.851	<.001
			United States	1.444	.841	.261
6500.00	Saudi Arabia	United States	.389	.494	1.000	
		India	-1.750*	.510	.002	
	United States	Saudi Arabia	-.389	.494	1.000	
		India	-2.139*	.523	<.001	
	India	Saudi Arabia	1.750*	.510	.002	
		United States	2.139*	.523	<.001	

Pairwise Comparisons

Dependent Variable: Scale_Response

Illuminance	CCT	(I) Group	(J) Group	95% Confidence Interval for Difference ^b	
				Lower Bound	Upper Bound
750.00	2700.00	Saudi Arabia	United States	-.091	5.091
			India	-.493	3.993
		United States	Saudi Arabia	-5.091	.091
			India	-2.993	1.493
		India	Saudi Arabia	-3.993	.493
			United States	-1.493	2.993
	4000.00	Saudi Arabia	United States	-3.189	-.672
			India	-5.423	-1.327
		United States	Saudi Arabia	.672	3.189
			India	-3.470	.581
		India	Saudi Arabia	1.327	5.423
			United States	-.581	3.470
6500.00	Saudi Arabia	United States	-.801	1.579	
		India	-2.979	-.521	
	United States	Saudi Arabia	-1.579	.801	
		India	-3.398	-.880	
	India	Saudi Arabia	.521	2.979	
		United States	.880	3.398	

Based on estimated marginal means

*. The mean difference is significant at the .05 level.

b. Adjustment for multiple comparisons: Bonferroni.

Univariate Tests

Dependent Variable: Scale_Response

Illuminance	CCT		Sum of Squares	df	Mean Square	F	Sig.
150.00	2700.00	Contrast	81.689	2	40.844	17.641	<.001
		Error	683.006	295	2.315		
	4000.00	Contrast	6.877	2	3.439	1.485	.228
		Error	683.006	295	2.315		
	6500.00	Contrast	14.844	2	7.422	3.206	.042
		Error	683.006	295	2.315		
450.00	2700.00	Contrast	9.833	2	4.917	2.124	.121
		Error	683.006	295	2.315		
	4000.00	Contrast	.309	2	.155	.067	.935
		Error	683.006	295	2.315		
	6500.00	Contrast	41.418	2	20.709	8.945	<.001
		Error	683.006	295	2.315		
750.00	2700.00	Contrast	13.500	2	6.750	2.915	.056
		Error	683.006	295	2.315		
	4000.00	Contrast	51.385	2	25.692	11.097	<.001
		Error	683.006	295	2.315		
	6500.00	Contrast	43.556	2	21.778	9.406	<.001
		Error	683.006	295	2.315		

Each F tests the simple effects of Group within each level combination of the other effects shown. These tests are based on the linearly independent pairwise comparisons among the estimated marginal means.

2. Group * Illuminance * CCT

Estimates

Dependent Variable: Scale_Response

Group	Illuminance	CCT	Mean	Std. Error	95% Confidence Interval	
					Lower Bound	Upper Bound
Saudi Arabia	150.00	2700.00	5.800	.340	5.130	6.470
		4000.00	4.500	.340	3.830	5.170
		6500.00	5.500	.761	4.003	6.997
	450.00	2700.00	5.000	.439	4.136	5.864
		4000.00	4.200	.340	3.530	4.870
		6500.00	7.000	.761	5.503	8.497
	750.00	2700.00	6.500	.761	5.003	7.997
		4000.00	2.625	.380	1.876	3.374
		6500.00	3.500	.340	2.830	4.170
United States	150.00	2700.00	5.556	.359	4.850	6.261
		4000.00	4.500	.439	3.636	5.364
		6500.00	5.000	.761	3.503	6.497
	450.00	2700.00	5.333	.621	4.111	6.556
		4000.00	4.222	.359	3.516	4.928
		6500.00	3.500	.538	2.441	4.559
	750.00	2700.00	4.000	.761	2.503	5.497
		4000.00	4.556	.359	3.850	5.261
		6500.00	3.111	.359	2.405	3.817
India	150.00	2700.00	3.000	.380	2.251	3.749
		4000.00	3.333	.621	2.111	4.556
		6500.00	3.571	.407	2.771	4.372
	450.00	2700.00	3.667	.621	2.444	4.889
		4000.00	4.375	.380	3.626	5.124
		6500.00	3.400	.481	2.453	4.347
	750.00	2700.00	4.750	.538	3.691	5.809
		4000.00	6.000	.761	4.503	7.497
		6500.00	5.250	.380	4.501	5.999

Pairwise Comparisons

Dependent Variable: Scale_Response

Group	CCT	(I) Illuminance	(J) Illuminance	Mean Difference (I-J)	Std. Error	Sig. ^b
Saudi Arabia	2700.00	150.00	450.00	.800	.556	.453
			750.00	-.700	.833	1.000
		450.00	150.00	-.800	.556	.453
			750.00	-1.500	.878	.266
		750.00	150.00	.700	.833	1.000
			450.00	1.500	.878	.266
	4000.00	150.00	450.00	.300	.481	1.000
			750.00	1.875*	.510	<.001
		450.00	150.00	-.300	.481	1.000
			750.00	1.575*	.510	.007
		750.00	150.00	-1.875*	.510	<.001
			450.00	-1.575*	.510	.007
	6500.00	150.00	450.00	-1.500	1.076	.493
			750.00	2.000	.833	.051
		450.00	150.00	1.500	1.076	.493
			750.00	3.500*	.833	<.001
		750.00	150.00	-2.000	.833	.051
			450.00	-3.500*	.833	<.001
United States	2700.00	150.00	450.00	.222	.717	1.000
			750.00	1.556	.841	.196
		450.00	150.00	-.222	.717	1.000
			750.00	1.333	.982	.527
		750.00	150.00	-1.556	.841	.196
			450.00	-1.333	.982	.527
	4000.00	150.00	450.00	.278	.567	1.000
			750.00	-.056	.567	1.000
		450.00	150.00	-.278	.567	1.000
			750.00	-.333	.507	1.000
		750.00	150.00	.056	.567	1.000
			450.00	.333	.507	1.000
	6500.00	150.00	450.00	1.500	.932	.326
			750.00	1.889	.841	.076
		450.00	150.00	-1.500	.932	.326
			750.00	.389	.647	1.000
		750.00	150.00	-1.889	.841	.076
			450.00	-.389	.647	1.000

Pairwise Comparisons

Dependent Variable: Scale_Response

Group	CCT	(I) Illuminance	(J) Illuminance	95% Confidence Interval for Difference ^b	
				Lower Bound	Upper Bound
Saudi Arabia	2700.00	150.00	450.00	-.538	2.138
			750.00	-2.707	1.307
		450.00	150.00	-2.138	.538
			750.00	-3.615	.615
		750.00	150.00	-1.307	2.707
	450.00		150.00	-.615	3.615
			450.00	-.859	1.459
	4000.00	150.00	450.00	-.859	1.459
			750.00	.646	3.104
		450.00	150.00	-1.459	.859
			750.00	.346	2.804
		750.00	150.00	-3.104	-.646
	450.00		150.00	-2.804	-.346
			450.00	-4.091	1.091
	6500.00	150.00	450.00	-4.091	1.091
750.00			-.007	4.007	
450.00		150.00	-1.091	4.091	
		750.00	1.493	5.507	
750.00		150.00	-4.007	.007	
	450.00	150.00	-5.507	-1.493	
		450.00	-1.505	1.949	
United States	2700.00	150.00	450.00	-1.505	1.949
			750.00	-.470	3.581
		450.00	150.00	-1.949	1.505
			750.00	-1.031	3.698
		750.00	150.00	-3.581	.470
	450.00		150.00	-3.698	1.031
			450.00	-1.088	1.643
	4000.00	150.00	450.00	-1.088	1.643
			750.00	-1.421	1.310
		450.00	150.00	-1.643	1.088
			750.00	-1.555	.888
		750.00	150.00	-1.310	1.421
	450.00		150.00	-.888	1.555
			450.00	-.743	3.743
	6500.00	150.00	450.00	-.743	3.743
750.00			-.136	3.914	
450.00		150.00	-3.743	.743	
		750.00	-1.168	1.946	
750.00		150.00	-3.914	.136	
	450.00	150.00	-1.946	1.168	
		450.00	-1.946	1.168	

Pairwise Comparisons

Dependent Variable: Scale_Response

Group	CCT	(I) Illuminance	(J) Illuminance	Mean Difference (I-J)	Std. Error	Sig. ^b
India	2700.00	150.00	450.00	-.667	.728	1.000
			750.00	-1.750*	.659	.025
		450.00	150.00	.667	.728	1.000
			750.00	-1.083	.822	.565
		750.00	150.00	1.750*	.659	.025
			450.00	1.083	.822	.565
	4000.00	150.00	450.00	-1.042	.728	.461
			750.00	-2.667*	.982	.021
		450.00	150.00	1.042	.728	.461
			750.00	-1.625	.851	.171
		750.00	150.00	2.667*	.982	.021
			450.00	1.625	.851	.171
6500.00	150.00	450.00	.171	.630	1.000	
		750.00	-1.679*	.557	.008	
	450.00	150.00	-.171	.630	1.000	
		750.00	-1.850*	.613	.008	
	750.00	150.00	1.679*	.557	.008	
		450.00	1.850*	.613	.008	

Pairwise Comparisons

Dependent Variable: Scale_Response

Group	CCT	(I) Illuminance	(J) Illuminance	95% Confidence Interval for Difference ^b	
				Lower Bound	Upper Bound
India	2700.00	150.00	450.00	-2.420	1.087
			750.00	-3.336	-.164
		450.00	150.00	-1.087	2.420
			750.00	-3.062	.895
	4000.00	150.00	450.00	.164	3.336
			750.00	-.895	3.062
		450.00	450.00	-2.795	.712
			750.00	-5.031	-.302
	6500.00	150.00	450.00	-.712	2.795
			750.00	-3.673	.423
		450.00	450.00	.302	5.031
			750.00	-.423	3.673
750.00	150.00	450.00	-1.345	1.688	
		750.00	-3.019	-.338	
	450.00	450.00	-1.688	1.345	
		750.00	-3.327	-.373	
750.00	150.00	.338	3.019		
	450.00	.373	3.327		

Based on estimated marginal means

*. The mean difference is significant at the .05 level.

b. Adjustment for multiple comparisons: Bonferroni.

Univariate Tests

Dependent Variable: Scale_Response

Group	CCT		Sum of Squares	df	Mean Square	F	Sig.
Saudi Arabia	2700.00	Contrast	8.356	2	4.178	1.804	.166
		Error	683.006	295	2.315		
	4000.00	Contrast	34.907	2	17.454	7.538	<.001
		Error	683.006	295	2.315		
	6500.00	Contrast	47.714	2	23.857	10.304	<.001
		Error	683.006	295	2.315		
United States	2700.00	Contrast	7.937	2	3.968	1.714	.182
		Error	683.006	295	2.315		
	4000.00	Contrast	1.111	2	.556	.240	.787
		Error	683.006	295	2.315		
	6500.00	Contrast	11.689	2	5.844	2.524	.082
		Error	683.006	295	2.315		
India	2700.00	Contrast	16.367	2	8.183	3.534	.030
		Error	683.006	295	2.315		
	4000.00	Contrast	17.071	2	8.535	3.686	.026
		Error	683.006	295	2.315		
	6500.00	Contrast	29.571	2	14.786	6.386	.002
		Error	683.006	295	2.315		

Each F tests the simple effects of Illuminance within each level combination of the other effects shown. These tests are based on the linearly independent pairwise comparisons among the estimated marginal means.

3. Group * Illuminance * CCT

Estimates

Dependent Variable: Scale_Response

Group	Illuminance	CCT	Mean	Std. Error	95% Confidence Interval	
					Lower Bound	Upper Bound
Saudi Arabia	150.00	2700.00	5.800	.340	5.130	6.470
		4000.00	4.500	.340	3.830	5.170
		6500.00	5.500	.761	4.003	6.997
	450.00	2700.00	5.000	.439	4.136	5.864
		4000.00	4.200	.340	3.530	4.870
		6500.00	7.000	.761	5.503	8.497
	750.00	2700.00	6.500	.761	5.003	7.997
		4000.00	2.625	.380	1.876	3.374
		6500.00	3.500	.340	2.830	4.170
United States	150.00	2700.00	5.556	.359	4.850	6.261
		4000.00	4.500	.439	3.636	5.364
		6500.00	5.000	.761	3.503	6.497
	450.00	2700.00	5.333	.621	4.111	6.556
		4000.00	4.222	.359	3.516	4.928
		6500.00	3.500	.538	2.441	4.559
	750.00	2700.00	4.000	.761	2.503	5.497
		4000.00	4.556	.359	3.850	5.261
		6500.00	3.111	.359	2.405	3.817
India	150.00	2700.00	3.000	.380	2.251	3.749
		4000.00	3.333	.621	2.111	4.556
		6500.00	3.571	.407	2.771	4.372
	450.00	2700.00	3.667	.621	2.444	4.889
		4000.00	4.375	.380	3.626	5.124
		6500.00	3.400	.481	2.453	4.347
	750.00	2700.00	4.750	.538	3.691	5.809
		4000.00	6.000	.761	4.503	7.497
		6500.00	5.250	.380	4.501	5.999

Pairwise Comparisons

Dependent Variable: Scale_Response

Group	Illuminance	(I) CCT	(J) CCT	Mean Difference (I-J)	Std. Error	Sig. ^b	95% Confidence Interval for ...	
							Lower Bound	
Saudi Arabia	150.00	2700.00	4000.00	1.300*	.481	.022	.141	
			6500.00	.300	.833	1.000	-1.707	
		4000.00	2700.00	-1.300*	.481	.022	-2.459	
			6500.00	-1.000	.833	.693	-3.007	
		6500.00	2700.00	-.300	.833	1.000	-2.307	
			4000.00	1.000	.833	.693	-1.007	
	450.00	2700.00	4000.00	.800	.556	.453	-.538	
			6500.00	-2.000	.878	.071	-4.115	
		4000.00	2700.00	-.800	.556	.453	-2.138	
			6500.00	-2.800*	.833	.003	-4.807	
		6500.00	2700.00	2.000	.878	.071	-.115	
			4000.00	2.800*	.833	.003	.793	
	750.00	2700.00	4000.00	3.875*	.851	<.001	1.827	
			6500.00	3.000*	.833	.001	.993	
		4000.00	2700.00	-3.875*	.851	<.001	-5.923	
			6500.00	-.875	.510	.262	-2.104	
		6500.00	2700.00	-3.000*	.833	.001	-5.007	
			4000.00	.875	.510	.262	-.354	
	United States	150.00	2700.00	4000.00	1.056	.567	.191	-.310
				6500.00	.556	.841	1.000	-1.470
			4000.00	2700.00	-1.056	.567	.191	-2.421
6500.00				-.500	.878	1.000	-2.615	
6500.00			2700.00	-.556	.841	1.000	-2.581	
			4000.00	.500	.878	1.000	-1.615	
450.00		2700.00	4000.00	1.111	.717	.367	-.616	
			6500.00	1.833	.822	.079	-.145	
		4000.00	2700.00	-1.111	.717	.367	-2.838	
			6500.00	.722	.647	.795	-.834	
		6500.00	2700.00	-1.833	.822	.079	-3.812	
			4000.00	-.722	.647	.795	-2.279	
750.00		2700.00	4000.00	-.556	.841	1.000	-2.581	
			6500.00	.889	.841	.874	-1.136	
		4000.00	2700.00	.556	.841	1.000	-1.470	
			6500.00	1.444*	.507	.014	.223	

Pairwise Comparisons

Dependent Variable: Scale_Response

Group	Illuminance	(I) CCT	(J) CCT	95% Confidence Interval for ...
				Upper Bound
Saudi Arabia	150.00	2700.00	4000.00	2.459
			6500.00	2.307
		4000.00	2700.00	-.141
			6500.00	1.007
			2700.00	1.707
	450.00	2700.00	4000.00	2.138
			6500.00	.115
		4000.00	2700.00	.538
			6500.00	-.793
			2700.00	4.115
	750.00	2700.00	4000.00	4.807
			6500.00	5.923
		4000.00	2700.00	5.007
			6500.00	-1.827
			2700.00	.354
United States	150.00	2700.00	4000.00	-993
			6500.00	2.104
		4000.00	2700.00	2.421
			6500.00	2.581
			2700.00	.310
450.00	2700.00	4000.00	1.615	
		6500.00	1.470	
	4000.00	2700.00	2.615	
		6500.00	2.838	
		2700.00	3.812	
750.00	2700.00	4000.00	.616	
		6500.00	2.279	
	4000.00	2700.00	.145	
		6500.00	.834	
		2700.00	1.470	
United States	150.00	2700.00	4000.00	1.470
			6500.00	2.914
		4000.00	2700.00	2.581
United States	450.00	2700.00	4000.00	2.666
			6500.00	
		4000.00	2700.00	

Pairwise Comparisons

Dependent Variable: Scale_Response

Group	Illuminance	(I) CCT	(J) CCT	Mean Difference (I-J)	Std. Error	Sig. ^b	95% Confidence Interval for ...
							Lower Bound
India		6500.00	2700.00	-.889	.841	.874	-2.914
			4000.00	-1.444*	.507	.014	-2.666
	150.00	2700.00	4000.00	-.333	.728	1.000	-2.087
			6500.00	-.571	.557	.917	-1.912
		4000.00	2700.00	.333	.728	1.000	-1.420
			6500.00	-.238	.742	1.000	-2.026
		6500.00	2700.00	.571	.557	.917	-.769
			4000.00	.238	.742	1.000	-1.550
	450.00	2700.00	4000.00	-.708	.728	.995	-2.462
			6500.00	.267	.786	1.000	-1.625
		4000.00	2700.00	.708	.728	.995	-1.045
			6500.00	.975	.613	.339	-.502
		6500.00	2700.00	-.267	.786	1.000	-2.159
			4000.00	-.975	.613	.339	-2.452
	750.00	2700.00	4000.00	-1.250	.932	.542	-3.493
			6500.00	-.500	.659	1.000	-2.086
		4000.00	2700.00	1.250	.932	.542	-.993
			6500.00	.750	.851	1.000	-1.298
6500.00		2700.00	.500	.659	1.000	-1.086	
		4000.00	-.750	.851	1.000	-2.798	

Pairwise Comparisons

Dependent Variable: Scale_Response

Group	Illuminance	(I) CCT	(J) CCT	95% Confidence Interval for ... b.
				Upper Bound
India	150.00	6500.00	2700.00	1.136
			4000.00	-.223
		2700.00	4000.00	1.420
			6500.00	.769
		4000.00	2700.00	2.087
			6500.00	1.550
	450.00	6500.00	2700.00	1.912
			4000.00	2.026
		2700.00	4000.00	1.045
			6500.00	2.159
		4000.00	2700.00	2.462
			6500.00	2.452
750.00	6500.00	2700.00	1.625	
		4000.00	.502	
	2700.00	4000.00	.993	
		6500.00	1.086	
	4000.00	2700.00	3.493	
		6500.00	2.798	
6500.00	2700.00	2.086		
	4000.00	1.298		

Based on estimated marginal means

*. The mean difference is significant at the .05 level.

b. Adjustment for multiple comparisons: Bonferroni.

Univariate Tests

Dependent Variable: Scale_Response

Group	Illuminance		Sum of Squares	df	Mean Square	F	Sig.
Saudi Arabia	150.00	Contrast	17.345	2	8.673	3.746	.025
		Error	683.006	295	2.315		
	450.00	Contrast	27.022	2	13.511	5.836	.003
		Error	683.006	295	2.315		
	750.00	Contrast	48.150	2	24.075	10.398	<.001
		Error	683.006	295	2.315		
United States	150.00	Contrast	8.085	2	4.042	1.746	.176
		Error	683.006	295	2.315		
	450.00	Contrast	11.556	2	5.778	2.496	.084
		Error	683.006	295	2.315		
	750.00	Contrast	18.878	2	9.439	4.077	.018
		Error	683.006	295	2.315		
India	150.00	Contrast	2.460	2	1.230	.531	.588
		Error	683.006	295	2.315		
	450.00	Contrast	6.392	2	3.196	1.380	.253
		Error	683.006	295	2.315		
	750.00	Contrast	4.214	2	2.107	.910	.404
		Error	683.006	295	2.315		

Each F tests the simple effects of CCT within each level combination of the other effects shown. These tests are based on the linearly independent pairwise comparisons among the estimated marginal means.

Post Hoc Tests

Group

Multiple Comparisons

Dependent Variable: Scale_Response

Tukey HSD

(I) Group	(J) Group	Mean Difference (I-J)	Std. Error	Sig.	95% Confidence Interval	
					Lower Bound	Upper Bound
Saudi Arabia	United States	.1060	.20282	.860	-.3718	.5837
	India	.4208	.20835	.109	-.0700	.9116
United States	Saudi Arabia	-.1060	.20282	.860	-.5837	.3718
	India	.3149	.21438	.308	-.1901	.8199
India	Saudi Arabia	-.4208	.20835	.109	-.9116	.0700
	United States	-.3149	.21438	.308	-.8199	.1901

Based on observed means.

The error term is Mean Square(Error) = 2.315.

Homogeneous Subsets

Scale_Response

Tukey HSD^{a,b,c}

Group	N	Subset
		1
India	96	4.0625
United States	106	4.3774
Saudi Arabia	120	4.4833
Sig.		.110

Means for groups in homogeneous subsets are displayed.

Based on observed means.

The error term is Mean Square(Error) = 2.315.

- Uses Harmonic Mean Sample Size = 106.444.
- The group sizes are unequal. The harmonic mean of the group sizes is used. Type I error levels are not guaranteed.
- Alpha = .05.

Illuminance

Multiple Comparisons

Dependent Variable: Scale_Response

Tukey HSD

(I) Illuminance	(J) Illuminance	Mean Difference (I-J)	Std. Error	Sig.	95% Confidence Interval	
					Lower Bound	Upper Bound
150.00	450.00	.2214	.20848	.538	-.2697	.7125
	750.00	.5058*	.20432	.037	.0245	.9871
450.00	150.00	-.2214	.20848	.538	-.7125	.2697
	750.00	.2844	.21116	.370	-.2130	.7819
750.00	150.00	-.5058*	.20432	.037	-.9871	-.0245
	450.00	-.2844	.21116	.370	-.7819	.2130

Based on observed means.

The error term is Mean Square(Error) = 2.315.

*. The mean difference is significant at the .05 level.

Homogeneous Subsets

Scale_Response

Tukey HSD^{a,b,c}

Illuminance	N	Subset	
		1	2
750.00	108	4.0556	
450.00	100	4.3400	4.3400
150.00	114		4.5614
Sig.		.359	.537

Means for groups in homogeneous subsets are displayed.

Based on observed means.

The error term is Mean Square(Error) = 2.315.

- Uses Harmonic Mean Sample Size = 107.024.
- The group sizes are unequal. The harmonic mean of the group sizes is used. Type I error levels are not guaranteed.
- Alpha = .05.

CCT

Multiple Comparisons

Dependent Variable: Scale_Response

Tukey HSD

(I) CCT	(J) CCT	Mean Difference (I-J)	Std. Error	Sig.	95% Confidence Interval	
					Lower Bound	Upper Bound
2700.00	4000.00	.7031*	.20601	.002	.2178	1.1884
	6500.00	.8723*	.21967	<.001	.3549	1.3898
4000.00	2700.00	-.7031*	.20601	.002	-1.1884	-.2178
	6500.00	.1692	.20356	.684	-.3103	.6487
6500.00	2700.00	-.8723*	.21967	<.001	-1.3898	-.3549
	4000.00	-.1692	.20356	.684	-.6487	.3103

Based on observed means.

The error term is Mean Square(Error) = 2.315.

*. The mean difference is significant at the .05 level.

Homogeneous Subsets

Scale_Response

Tukey HSD^{a,b,c}

CCT	N	Subset	
		1	2
6500.00	98	4.0000	
4000.00	130	4.1692	
2700.00	94		4.8723
Sig.		.699	1.000

Means for groups in homogeneous subsets are displayed.

Based on observed means.

The error term is Mean Square(Error) = 2.315.

- a. Uses Harmonic Mean Sample Size = 105.135.
- b. The group sizes are unequal. The harmonic mean of the group sizes is used. Type I error levels are not ...
- c. Alpha = .05.

Profile Plots

Illuminance * CCT * Group

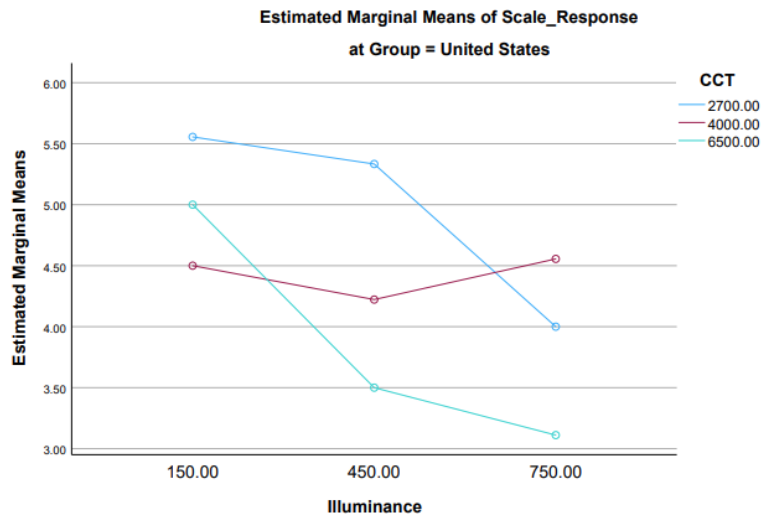
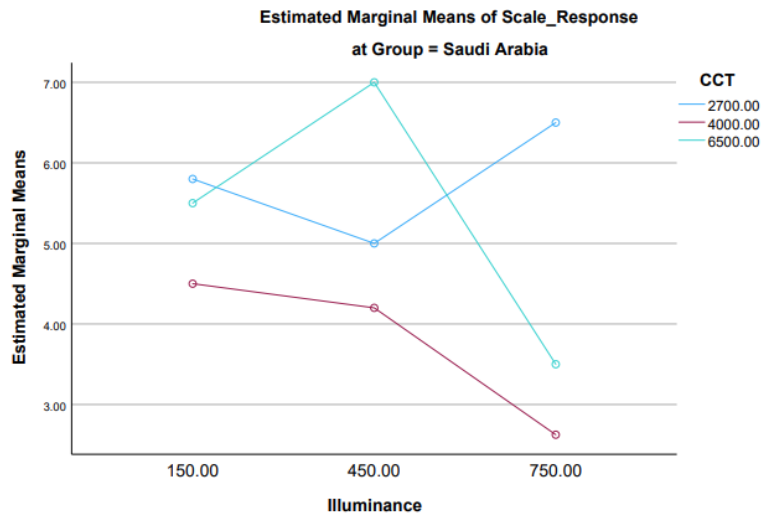

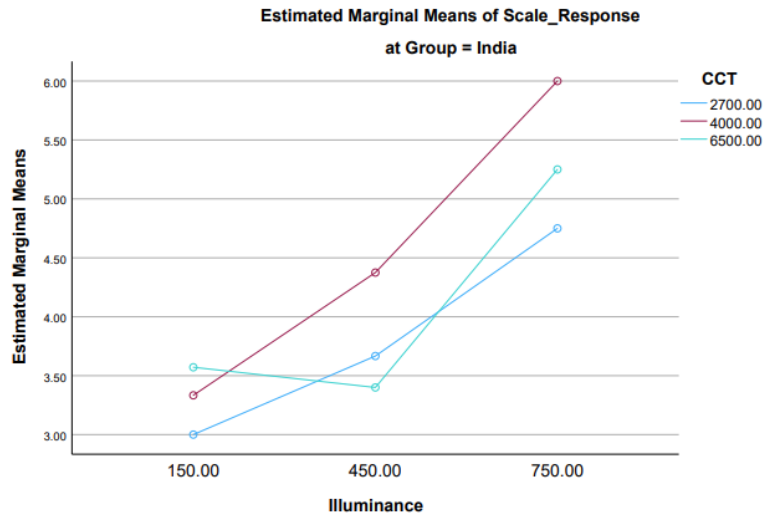

Appendix 19. Visual Performance & Light Preference Correlation Data Analysis Process.

Correlations

			Scale_Response	Build_Time
Spearman's rho	Scale_Response	Correlation Coefficient	1.000	.027
		Sig. (2-tailed)	.	.628
		N	322	322
	Build_Time	Correlation Coefficient	.027	1.000
		Sig. (2-tailed)	.628	.
		N	322	322

Nonparametric Correlations - Preference vs Build Time - I Like the Light Scene

Appendix 20. Light Preference Exhaust CHAID Splits (Classification Tree).

