

INFLUENCE OF ENGINEERING INFORMATION FORMAT,
DEMOGRAFICS AND SPATIAL COGNITION ON CRAFT WORKER
PERFORMANCE

by

OMAR FALAH ALRUWAYTHI

B.S., Civil Eng. King Saud University, 2007

M.S., Civil Eng. University of Colorado at Boulder, 2013

A thesis submitted to the

Faculty of the Graduate School of the

University of Colorado in partial fulfillment

of the requirement for the degree of

Doctor of Philosophy

Department of Civil, Environment, and Architectural Engineering

2017

This dissertation entitled:
Influence of Engineering Information Format, Demographics, and Spatial Cognition on Craft
Worker Performance
Written by Omar F. Alruwaythi
has been approved for the Department of Civil, Environmental, and Architectural Engineering

(Professor Paul M. Goodrum, Chair)

(Professor Keith R. Molenaar)

(Professor Matthew R. Hallowell)

(Professor Tom Yeh)

(Professor Robert M. Leicht)

Date _____

The final copy of this dissertation has been examined by the signatories, and we find that both the content and the form meet acceptable presentation standards of scholarly work in the above-mentioned discipline

IRB protocol # 16-0165

EXECUTIVE SUMMARY

Omar Alruwaythi (Ph.D., Civil Engineering)

Influence of Engineering Information Format, Demographics, and Spatial Cognition on Craft Worker Performance.

Dissertation directed by: Professor Paul M. Goodrum

Purpose: The main goal of this dissertation was to improve the effectiveness of construction craft workers in using the engineering information format when completing complex construction tasks.

Background: The construction productivity of craft workers can be negatively impacted by ineffective communication of the project's design and information. Traditional information delivery relies on two-dimensional drawings for multiple views, which typically require workers to have high spatial cognitive abilities in order to effectively understand how to interpret and combine all views of the two-dimensional (2D) drawings. Advancements in three-dimensional (3D) computer-aided design (CAD), augmented reality, virtual reality, and 3D printing have provided new format options for delivering engineering information in a way that is easier to understand.

Intellectual Merit: The dissertation describes a set of field trials based on experimental designs and the use of eye tracking technology to explore the interrelation between spatial cognition, demographic traits, and engineering information formats in their impact on the performance of construction craft workers. The aim of the dissertation was to generate new knowledge in several respects by (1) introducing primary constructs regarding the information needs of construction craft workers; (2) quantifying the influence of various engineering information deliverables, demographics, and spatial cognition that captures the individual performance of craft workers; (3) reviewing the guidelines for providing tailored information systems to accommodate unique craft

worker demographics and requirements of spatial cognition; and (4) revising proposals and additional recommendations to transform information systems implemented for craft workers.

Broader Impact: This dissertation opens channels for extensive transformative findings on how to more naturally incorporate information interfaces with people. Recognition of cognitive aspects of spatial information processing based on different information formats and craft worker demographics provides a better understanding of how to improve information systems and the performance of individuals engaged in frontline tasks in other industries. This is done by understanding how information format can be tailored for broader ranges of populations with diverse spatial cognition and demographics.

ACKNOWLEDGEMENTS

I would first like to express my sincere gratitude and appreciation to my advisor, Dr. Paul Goodrum, for his tremendous support, motivation, excellent cooperation, and immense knowledge. His guidance and insightful comments helped me to conduct my research in a timely manner.

I also want to thank my committee members; Dr. Keith Molenaar, Dr. Matthew Hallowell, Dr. Tom Yeh, and Dr. Robert Leicht for their valuable guidance, knowledge, and insights that had greatly enriched my work and increased my knowledge.

Furthermore, I wish to thank my fellow graduate students for their cooperation, feedback, help, and friendship. In addition, I gratefully acknowledge Mr. Gary Arnold and Mr. Zach Collins from Denver pipefitters local union for their support in recruiting craft workers in my research. I also would like to thank the craft workers who gave their time and effort to participate in my research experiments.

Importantly, my sincerest thanks and gratitude to my parents, Falah Alruwaythi (may Allah have mercy on him and forgive him) and Mooqfah Alruwaythi, for their love, support, motivation, and wise counsel throughout my life. I also would like to thank my family members, including my brothers, sisters, and in-laws for their encouragements and continuous support.

Lastly and most especially, I would like to express the deepest thanks and appreciation to my wife, Azhar Alfuhaydi, for her love, patience, encouragement, and support, as well as for taking care of our kids during this challenging journey. I also thank my two wonderful children, Razi and Zofa, who have brought me more love, joy, and happiness.

TABLE OF CONTENTS

CHAPTER 1: INTRODUCTION	1
1.1 Background and Motivation.....	1
1.2 Previous Research and Current Needs for Additional Research	3
1.3 Dissertation Organization.....	5
1.4 Dissertation Conceptual Overview.....	6
1.5 Dissertation Format, Objectives, and Hypothesis	7
References	9
CHAPTER 2: INFLUENCE OF USING DIFFERENT ENGINEERING INFORMATION FORMATS WITH INCREASING DESIGN COMPLEXITY ON CRAFT WORKER PERFORMANCE	10
2.1 Abstract	10
2.2 Introduction.....	11
2.3 Formats of Engineering Deliverables.....	12
2.3.1 Two-Dimensional Drawings (2D)	12
2.3.2 Isometric Drawing	13
2.3.3 Computer Aided Design (CAD)	13
2.3.4 Building Information Modeling (BIM).....	14
2.3.5 Physical Scaled 3D Models	15
2.4 Previous Construction Research Designs.....	15
2.5 Methodology	18
2.5.1 Task Design	18
2.5.2 Baseline Testing.....	22
2.5.3 Field Trials.....	25
2.5.3.1 Participants	25

2.5.3.2	Experiment Method	25
2.5.3.3	Experiment Metrics.....	25
2.6	Field Trial Results	27
2.6.1	Effects of Information Format in each Design.....	27
2.6.2	Comparing the Effects of 3D Information Formats.	31
2.7	Limitations	32
2.8	Conclusions.....	33
	References	35
CHAPTER 3: THE RELATIONSHIP BETWEEN ENGINEERING INFORMATION FORMAT, SPATIAL COGNITION, AND DEMOGRAPHICS IN CRAFT WORKER PERFORMANCE.....		
3.1	Abstract	37
3.2	Introduction.....	38
3.2.1	Influence of Engineering Information Deliverables in the Construction Industry.....	38
3.3	Spatial Cognition.....	39
3.3.1	Individual differences in spatial cognition.....	40
3.3.2	Spatial cognition tests	41
3.4	Influence of Engineering Format and Spatial Cognition in Construction Industry.....	42
3.5	Related works from other domains	44
3.6	Methodology	46
3.6.1	Task Design	46
3.6.2	Participants.	48
3.6.3	Demographics Questionnaire.....	48
3.6.4	Spatial Cognition Tests.....	48
3.6.5	Experiment Method	48

3.6.6	Experiment metrics	50
3.7	Field Trial Results.	51
3.7.1	Effects of Spatial Cognition and Information Format on Craft Performance.	51
3.7.1.1	Effects of Information Format, Controlling for Composite Spatial Cognition Scores.	52
3.7.1.2	Effects of Composite Spatial Cognition Scores, Controlling for Information Format.	53
3.7.2	Effects of Age, Work Experience and Information Format.	55
3.7.2.1	Effects of Information Format, Controlling for Age.	55
3.7.2.2	Effects of Age, Controlling for Information Format.	56
3.7.2.3	Effects of Information Format, Controlling for Work Experience.	58
3.7.2.4	Effects of Work Experience, Controlling for Information Format.	59
3.8	Limitations	60
3.9	Conclusion	61
	References	64
 CHAPTER 4: THE IMPACT OF DIFFERENT FORMATS OF ENGINEERING INFORMATION AND SPATIAL COGNITION ON CRAFT WORKER EYE GAZE PATTERNS		67
4.1	Abstract	67
4.2	Introduction	68
4.3	Previous Construction Research	69
4.4	Eye Tracking Technology	71
4.5	Eye Tracking Measures	71
4.6	How an Eye Tracker Works	73
4.7	Eye Tracking Application Areas	73
4.8	Eye Tracking in Construction Engineering	74
4.9	Methodology	75

4.9.1	Task Design	75
4.9.2	Participants	77
4.9.3	Spatial Cognition Tests	78
4.9.4	Experiment Method	79
4.9.5	Eye Tracking Data	82
4.10	Field Trial Results	82
4.10.1	Effects of Information Format on Craft Worker Performance	82
4.10.2	Effects of Information Format on Craft Worker Eye Gaze Patterns.	83
4.10.3	Effects of Inf. Format and Spatial Cognition on Performance and Eye Gaze Patterns	87
4.10.3.1	Effects of Spatial Cognition on Performance, Controlling for Information Format.	90
4.10.3.2	Effects of Spatial Cognition on Eye Gaze Pattern, Controlling for Information Format.	91
4.10.3.3	The relationship between Spatial Cognition and 3D Information	92
4.11	Experiment Limitations	97
4.12	Conclusion	97
	References	100
	CHAPTER 5: CONCLUSIONS	103
5.1	Contributions.....	103
5.2	Suggestions for Future Research.....	107
5.2.1	Limitations of Current Datasets	107
5.2.2	Opportunities for Future Research.....	108
	INTEGRATED REFERENCES	111
	APPENDIX	116
1	The Three Information Formats for the Simple Design	116

2	The Three Information Formats for the Medium Design.....	118
3	The Three Information Formats for the Complex Design.....	121
4	Demographic Questionnaire.....	124
5	Card Rotation Answers	125
6	Cube Comparison Test Answers	127
7	Blank Analysis Sheet	129
8	IRB Approval	130

LIST OF TABLES

Table 1.1. Research Questions, Objectives, and Hypothesis.....	8
Table 2.1. Proposed Piping Models.....	20
Table 2.2. The three Piping Designs and their Information Formats.....	21
Table 2.3. Baseline testing Average Results for each Design.....	23
Table 2.4. Performance Metrics by the Simple and Medium Designs.....	23
Table 2.5. Performance Metrics by the Medium and Complex Designs.	24
Table 2.6. Performance Metrics by the Medium the Complex Designs (After Changes).....	25
Table 2.7. Performance Metrics by Information Format for each design	28
Table 2.8. Performance Metrics by 3D information Format for each design..	32
Table 2.9. Trends Statistically Proven.	33
Table 3.1. Performance Metrics by Information Format controlling for Composite Spatial Cognition	53
Table 3.2. Performance Metrics by Composite Spatial Cognition test controlling for Information format.....	54
Table 3.3. Performance Metrics by Information Type Controlling for Age	56
Table 3.4. Performance Metrics by Age Controlling for Information Format.....	57
Table 3.5. Performance Metrics by Information Type Controlling for Work Exp.	58
Table 3.6. Performance Metrics by Work Exp. Controlling for Information Format	60
Table 3.7. Trends Statistically Proven.	62
Table 4.1. Field Trial Results by Information Format	83
Table 4.2. Eye Tracking Data in the 2D Isometric Format.....	84
Table 4.3. Eye Tracking Data in the 2D Isometric plus 3D Image Format.	85
Table 4.4. Eye Tracking Data in the 2D Isometric plus 3D physical Format..	86
Table 4.5. Eye Tracking Metrics by Information Format.....	87

Table 4.6. Performance Metrics by Composite Spatial Cognition Controlling for Information Format.	90
Table 4.7. Eye Tracking Metrics by Spatial Cognition, Controlling for Information Format.	92
Table 4.8. Eye Tracking Metrics by Spatial Cognition Controlling for the use of 2D Iso vs. 3D Images.....	93
Table 4.9. Eye Tracking Metrics by Spatial Cognition, Controlling for the use of 2D iso vs. 3D physical	95
Table 4.10. Trends Statistically Proven.....	98
Table 5.1. Research Questions and Results.....	105

LIST OF FIGURES

Figure 1.1. A Time Series Stacked Bar Chart illustrating Hourly and Average Activity Results	3
Figure 1.2. The Interconnection of Information Formats, Spatial Cognition, and Demographics.....	6
Figure 2.1. The Complex Design Model before and after the Adjustments.	24
Figure 2.2. Field Trial Experiment	26
Figure 2.3. Total Time by Information Format.....	29
Figure 2.4. Direct Work by Information Format	29
Figure 2.5. Indirect Work by Information Format	30
Figure 2.6. Re-work by Information Format	30
Figure 2.7. Number of Errors by Information Format	31
Figure 3.1. Card Rotation Test	42
Figure 3.2. Cube Comparison Test	42
Figure 3.3. Piping Model.....	46
Figure 3.4. Two-Dimensional (2D) Isometric Drawings.....	47
Figure 3.5. 2D Isometric Drawings with a three-Dimensional (3D) Image.....	47
Figure 3.6. 2D Isometric Drawings supplemented with a 3D Physical Model.....	48
Figure 3.7. Field Trial Experiment	50
Figure 3.8. Total Time by Information Format and Spatial Cognition.....	54
Figure 3.9. Total Time by Information Format and Age	57
Figure 3.10. Total Time by Information Format and Work Experience	60
Figure 4.1. Piping Model.....	75
Figure 4.2. Two-Dimensional (2D) Isometric Drawings.....	76
Figure 4.3. 2D Isometric Drawings with a three-Dimensional (3D) Image.....	76

Figure 4.4. 2D Isometric Drawings supplemented with a 3D Physical Model	77
Figure 4.5. Card Rotation Test	78
Figure 4.6. Cube Comparison Test	78
Figure 4.7. Field Trial Experiment	79
Figure 4.8. Heat maps for 20 Participants in the 2D Isometric Format	84
Figure 4.9. Heat maps for 20 Participants in the 2D Isometric plus 3D Image Format	85
Figure 4.10. Heat maps for 20 Participants in the 2D Isometric plus 3D Physical Format	86
Figure 4.11. Heat map of Spool 5 in the 2D Isometric for Higher Spatial Cognition Group	89
Figure 4.12. Heat map of Spool 5 in the 2D Isometric for Lower Spatial Cognition Group	89
Figure 4.13. Heat map of Spool 5 in the 2D Isometric + 3D Image for Higher Spatial Group	89
Figure 4.14. Heat map of Spool 5 in the 2D Isometric + 3D Image for Lower Spatial Group	89
Figure 4.15. Heat map of Spool 5 in the 2D Isometric + 3D Physical Model for Higher Spatial Group	89
Figure 4.16. Heat map of Spool 5 in the 2D Isometric + 3D physical Model for Higher Spatial Group	89
Figure 4.17. Number of Fixation Spools 1 to 10 by H/L Spatial Group in the 2D+3D Image Format.....	94
Figure 4.18. Number of Fixation Spools 1 to 10 by H/L Spatial Group in the 2D+3D Physical Format	96

CHAPTER 1: INTRODUCTION

1.1 Background and Motivation

Engineering information deliverables are considered to be the essential outcome of design and play an integral role in the construction process that is utilized by craft to build a project. It can be deduced that engineering information deliverables are the drawings and specifications that are required by a craft to execute any task or process in a construction workface. Several decades ago, 3D visualization and data integration made considerable progress in the design and user interfaces of engineering systems. However in spite of the fact that 3D computer aided design (CAD) and building information models (BIM) are now predominant in design and planning, use of these same models by the crafts at the construction workface is still generally uncommon (Goodrum and Miller 2015). On the other hand, paper-based plans and files continue to be the fundamental formats applied to engineering information deliverables (Bowden et al., 2006). In this context, two-dimensional plan sets are the primary format of engineering deliverables at the construction workface. Drawing sets such as isometrics, plan sections or detailed sections involve the technical information details that are provided to craft-workers, which permit them to execute their construction tasks (Emmitt et al. 2003).

Although other elements play a vital role in the production processes among construction crews such as supervisor direction, safety, communication, drawing management, materials, project management, tools, and consumables as well as construction equipment (Dai et al., 2009), it is evident that the utilization of engineering information deliverables is an indispensable part of the production processes. Additionally, the availability and accuracy of engineering information play an important role on construction craft performance. Nevertheless, two-dimensional drawings that have been used for many years are still problematic to use in the construction workface. As

confirming, Liberda et al. (2003) asked industry experts to rank 51 variables that influence construction productivity in three classifications, which included human labor, management, and the external environment. In the survey, it was observed that a lack of essential information required to perform construction was ranked as the 8th among the 51 factors that were generally experienced by construction experts as obstructions to productivity.

Furthermore in view of the deductions from the craft workers, the significance of engineering information was observed to be more critical in a study by Naoum (2016) who did a survey with 36 construction firms and identified 46 factors affecting construction labor productivity. The delay caused by design error and change orders were ranked second while communication systems were ranked third. Additionally, the lack of integration of the management information systems for the projects was ranked ninth overall. The same pattern was observed in another similar survey by Dai et al. (2009a) with approximately 2,000 craft workers as participants, 40 percent of them were from piping and electrical trades. The survey results show that three among the ten most important issues in the engineering field revolved around the availability and accuracy of engineering drawings.

In addition, the absence of adequate engineering information influences craft productivity. Emmitt and Gorse (2003) identified negative results when information is given to a craft in forms that they did not prefer or that were not useful and meaningful to them. O'Connor (1985) reported that the lack of well-conveyed information to crafts results in productivity decline. In the construction workforce, time used in preparation and waiting is often as a result of information needs as observed by Gouett et al. (2011), who conducted activity analysis studies for six construction projects. The activity analysis was based on hourly observations for each worker in each trade. A time series stacked bar chart was made to illustrate hourly and average activity results

for all the trades present in the six construction projects as shown in Figure 1.1 below. Accumulatively, the findings confirmed that construction craft workers on construction sites used around 25% of their hourly time to prepare and wait for any information that was necessary.

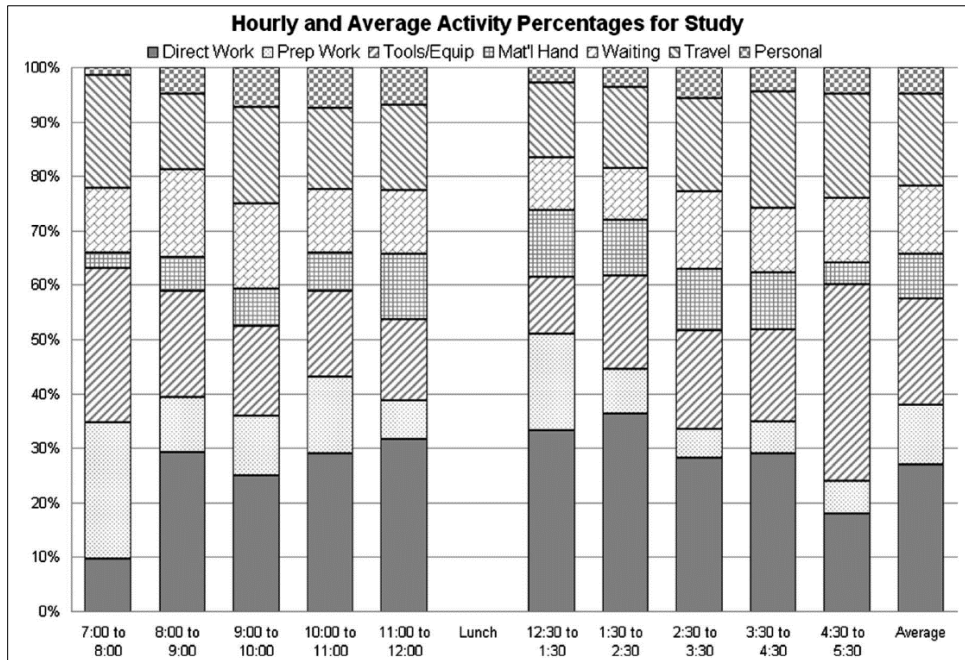

Figure 1.1. A Time Series Stacked Bar Chart illustrating Hourly and Average Activity Results by Gouett et al (2011)

The previous findings deduced the importance of engineering information deliverables on crafts performance. Adjustments in the acts of providing construction crafts the engineering drawings they need are essential to enhance their performance. Moreover, understanding how individual craft workers access, view or interpret the information they need to perform their tasks is a basic gap in the current body of knowledge that justifies further similar research.

1.2 Previous Research and Current Needs for Additional Research

This dissertation builds on the work of Dadi et al. (2014 a, b, c), Sweany et al. (2016) and Goodrum et al. (2016) who set the framework for measuring productivity by varying formats of engineering deliverables and spatial cognition. Dadi et al. (2014 a, b, c) examined the cognitive

load and the performance of 26 participants who used a series of 2D plan drawings, 3D CAD, and a 3D printed model to build scale model assemblies. The results indicate that greater cognitive demand was associated with 2D engineering deliverables and lower cognitive demands were associated with 3D engineering deliverables, but the authors were not able to fully identify a relationship between the format of engineering deliverables and craft performance. Through application of a different study plan with structural ironworkers, Sweany et al. (2016) identified a statistically significant relationship between information format and task performance. When participants used the 2D plan set, they performed worst as compared to using either the 3D CAD model or the 3D physical print. Goodrum et al. (2016) investigated how pipefitters' spatial cognition influenced their performance on a scale model assembly task. They successfully found that when only 2D information was provided, participants with relatively low spatial cognition performed significantly worse than participants with relatively higher spatial cognition. When the 2D isometric drawings were supplemented with 3D information, participants with lower spatial cognition were able to complete the model assembly as efficiently and effectively as participants with higher spatial cognition.

Some of the limitations of the previous studies (Dadi et al., 2014 a, b, c; Sweany et al., 2016; and Goodrum et al., 2016) has led to the current need for additional research. The weakness of their studies was that model designs were moderately straightforward, which was fundamental because of time restrictions of conducting the experiments, since each test was constrained to 30 minutes. Additionally, time was limited because the experiments were conducted during normal work hours, since each participant was being paid by their employer. The simplicity of the designs constrained the potential for confusion, rework, and mistakes as well as the reduction of the variance of the performance metrics. However in this dissertation, participants are paid for one

hour of their time with a specific end goal of permitting more opportunity to assemble more complex designs. Therefore, three designs with various complexities (simple, medium, and complex) are used to analyze whether returns in greater performance are experienced with increased design complexity. Despite the fact that there were observed essential and statistical differences by types of engineering information, more complex designs are justified to more thoroughly examine contributory components, such as age, work experience, training and spatial cognition. This dissertation addresses these concerns and other potential issues for new knowledge, such as analyzing how people with various spatial cognition and demographics interact differently with information and how variation in eye fixation patterns are associated with different formats of engineering information.

1.3 Dissertation Organization

This dissertation is organized into 5 chapters, the first chapter presents the background, motivation; previous research and current needs for additional research; dissertation organization, dissertation conceptual overview; dissertation format, objectives, and hypothesis; and references. Chapters 2, 3, and 4 follow a format of journal papers. Each chapter contains an abstract, introduction, literature review, research method, results, conclusions, and references. Overlaps should be observed in some aspects of these chapters. In particular, chapter 3 and 4 use the framework developed in Chapter 2. The final chapter, Chapter 5, provide the conclusion, which mainly summarizes the overall findings of the three papers (chapters 2, 3, and 4), as well as the contributions to the overall body of knowledge, limitation of the studies, and suggestions for future research studies.

1.4 Dissertation Conceptual Overview

The dissertation aims to improve the effectiveness of construction craft-workers in using engineering information. The significance of engineering information to the construction craft-workers goes beyond its accessibility and accuracy. Relatively, craft workers' ability to effectively utilize engineering deliverables is strongly dependent on the deliverable format, their demographics such as “age, work experience, education, and training”, as well as their spatial cognition as shown in Figure 1.2 below.

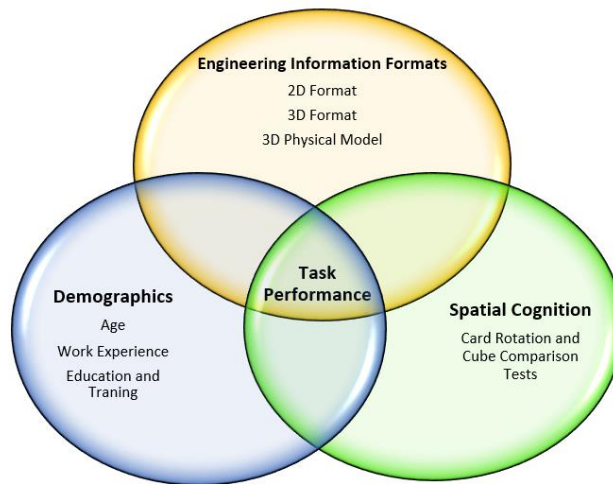

Figure 1.2. The Interconnection of Engineering Information Formats, Spatial Cognition, and Demographics Driving Task Performance.

In general, this dissertation utilizes an arrangement of field trials taking into account experimental designs to investigate the interconnection and interactions between information formats, craft demographics, and individual spatial cognition on their combined impact on craft-worker performance. Understanding this interface not only enhances the construction craft-workers' performance but also opens up the chances for more extensive transformative discoveries of how to integrate the information interface with people in a natural way. For example, how do age and work experience influence the ability to effectively use different types of information formats? How do high performance workers view and interpret the engineering drawings

compared to other workers who work less effectively? How does spatial cognition impact successful task completion, as well, as how can the format of information can be changed to accommodate broader populations with various types of spatial cognition and demographics.

The field trials in this research involves professional craft-workers in the mechanical, electrical, and plumbing (MEP) trades. These three trades involve the most complex engineering deliverables on most projects, and their work is often part of project's critical path and therefore influential to a project's overall schedule performance. The workers' performances in the experiments are measured by multiple performance metrics such as time to completion, direct and indirect work rates, rework, and installation errors. The spatial cognition is measured by two independent spatial cognition tests. Furthermore, the research takes advantages of eye tracking technology that creates visually and quantitatively accumulated gaze patterns in order to explore how workers with various spatial cognition and demographics interact with engineering information formats.

The dissertation findings are intended to create pathways toward better interface designs of information systems in the construction industry. Indeed, it is not just vital to have the right information at the ideal time, but also it is much more vital to have the right information at the perfect time and in the right format that is compatible to wide populations of construction craft workers.

1.5 Dissertation Format, Objectives, and Hypothesis

As mentioned, this dissertation contains 3 papers that address the research needs. The main objective of the three papers is to improve the effectiveness of construction craft-workers in using engineering information when completing construction tasks. Table 1.1 shows the research questions, objectives and hypothesis for each paper.

Table 1.1. Research Questions, Objectives, and Hypothesis.

Paper	Research questions	Research objectives	Research hypothesis
<p>Paper 1 (Chapter 2)</p>	<ul style="list-style-type: none"> • How do craft-workers perform in different formats of engineering information? • How does increasing design complexity interact with varying information formats in terms of workers performance? • How do craft-workers perform in using different types of 3D engineering information? 	<ul style="list-style-type: none"> • Quantify the effects of using different information formats in craft-workers performance. • Understand the influence that increasing design complexity has on the use of different information formats. • Examine the differences of using different types of 3D engineering information in craft-workers performance. 	<ul style="list-style-type: none"> • H1: Different formats of information influence task performance differently. • H2: The influence of different information formats on task performance become stronger when increasing design complexity. • H3: Different types of 3D information influence similarly in task performance.
<p>Paper 2 (Chapter 3)</p>	<ul style="list-style-type: none"> • In what ways are the relative utility of different formats contingent on the spatial abilities of users? • How does age and year of experience affect craft-workers' performance when using different formats of engineering information? 	<ul style="list-style-type: none"> • Quantify the effects of individual spatial cognition in the efficient and effective use of different information formats in executing an assigned task. • Examine the interaction between demographics and the use of different information formats. 	<ul style="list-style-type: none"> • H1: Craft-workers' spatial cognition influence differently in task performance when using different formats of engineering information. • H2: When using different information formats, Demographics (specifically age and work experience) influence differently in task performance. • H3: When using conventional 2D format of information, workers with lower spatial cognition/or experience perform worse in executing an assigned task, compared to workers with higher spatial cognition/or experience.
<p>Paper 3 (Chapter 4)</p>	<ul style="list-style-type: none"> • How do workers' gaze patterns differ depending on the use of different formats of engineering information? • How do spatial cognition affect workers' gaze pattern when using different information formats. 	<ul style="list-style-type: none"> • Explore the differences in gaze patterns in different formats of engineering information. • Examine the interaction between spatial cognition and gaze patterns when using different information formats. 	<ul style="list-style-type: none"> • H1: There are different eye gaze patterns when using different information formats. • H2: The improvement in performance when using different engineering information format is associated to eye gaze patterns. • H3 Differences in gaze patterns are associated with differences in spatial cognition. • H4: Workers with lower spatial cognition tend to fixate more on 3D information compared to workers with a higher spatial cognition.

References

- Bowden, S., Dorr, A., Thorpe, A., Anumba, C. (2006). "Mobile ICT Support for Construction Process Improvement". *Automation in Construction* Vol. 15 (5). 664–676.
- Dadi, G. B., Goodrum, P. M., Taylor, T. R., and Carswell, C. M. (2014a). "Cognitive Workload Demands Using 2D and 3D Spatial Engineering Information Formats". *Journal of Construction Engineering and Management*, 140(5).
- Dadi, G. B., Goodrum, P. M., Taylor, T. R., & Maloney, W. F. (2014b). "Effectiveness of communication of spatial engineering information through 3D CAD and 3D printed models". *Visualization in Engineering*, 2(1), 1-12.
- Dadi, G. B., Taylor, T. R., Goodrum, P. M., & Maloney, W. F. (2014c). "Performance of 3D computers and 3D printed models as a fundamental means for spatial engineering information visualization". *Canadian Journal of Civil Engineering*, 41(10), 869-877.
- Dai, J., Goodrum, P. M., and Maloney, W. F. (2009a). "Construction Craft Worker' Perceptions of the Factors Affecting Their Productivity". *Journal of Construction Engineering and Management*, (135), 217–226.
- Emmitt, S. and Gorse, C. (2003). "Construction Communication". *Blackwell Publishing*, Oxford.
- Goodrum, P. M., and Miller, J. M. (2015). "Innovative delivery methods of information to the crafts. Construction Industry Institute", *Univ. of Texas at Austin*, Austin, TX. RT 327.
- Goodrum, P., Miller, J., Sweany, J., and Alruwaythi, O. (2016). "Influence of the Format of Engineering Information and Spatial Cognition on Craft-Worker Performance". *Journal of Construction Engineering and Management*, Vol. 142, No. 9.
- Gouett, M., Haas, C., Goodrum, P., and Caldas, C. (2011). "Activity analysis for direct-work rate improvement in construction". ASCE. *Journal of Construction Engineering and Management*, 37: 1117-1124.
- Liberda, M., Ruwanpura, J., & Jergeas, G. (2003). "Construction Productivity Improvement: A Study of Human, Management and External Issues". ASCE. *Construction Research Congress*. 1–8. 10.1061/40671(2003)5
- Naoum, S. G., (2016). "Factors influencing labor productivity on construction sites: A state of the art literature review and a survey". *International Journal of Productivity and Performance Management*. ISSN: 1741-0401
- O'Connor, J. T. (1985). "Impacts of Constructability Improvement". ASCE. *Journal of Construction Engineering and Management*, (111) 404–410.
- Sweany, J., Goodrum, P., Miller, J. (2016). "Analysis of empirical data on the effects of the format of engineering deliverables on craft performance". *Automation in Construction*, Volume 69. (2016) 59-67

CHAPTER 2: INFLUENCE OF USING DIFFERENT ENGINEERING INFORMATION FORMATS WITH INCREASING DESIGN COMPLEXITY ON CRAFT WORKER PERFORMANCE

2.1 Abstract

The productivity of craft-workers can be negatively impacted by ineffective communication of the project's design and information. Traditional delivery of mechanical, electrical, and plumbing (MEP) designs rely on two-dimensional isometric drawings. Advancements in three-dimensional (3D) computer aided design, augmented reality, virtual reality, and 3D printing provide new format options to deliver engineering information. However, providing them to crafts for use at the construction workface remains relatively rare. A series of field trials with MEP workers was conducted to examine the influence of increasing task complexity and the use of different information formats on their performance in completing scale models task assembly. Participants were asked to assemble one of three scaled pipe designs (simple, medium, and complex designs) by using different information formats, ranging from two-dimensional (2D) isometric drawings to 2D isometric drawings supplemented with a 3D physical model of the assembly. The results support the research hypothesis that the use of different formats of engineering information significantly influenced task performance differently, the influence improved when task complexity increased. The study is expanding the current body of knowledge by examining the impact of engineering information formats on task complexity.

2.2 Introduction

3D visualization and data integration have made considerable progress when the design of engineering systems is concerned. However in spite of the fact that 3D computer aided design (CAD) and building information models (BIM) have become predominant in design, providing these models to the crafts at the construction workforce is still generally uncommon (Goodrum and Miller 2015). On the other hand, paper-based plans and files are continuously the fundamental formats applied to the engineering information deliverables (Bowden et al., 2006). In this context, a two-dimensional plan sets is the primary format of engineering deliverables at the construction workforce.

The utilization of engineering information deliverables is an indispensable part of the production processes among the construction crews. Additionally, the availability and accuracy of engineering information play an important role on construction craft performance. Nevertheless, two-dimensional drawings that have been used for many years and proved to be problematic. As such, Liberda et al. (2003) asked industry experts to rank 51 variables that influence construction productivity in three classifications, which included labor, management, and the external environment. In the survey, it was observed that lack of essential information required to perform construction was ranked as eighth out of 51 factors that were generally experienced by construction experts as obstructions to productivity.

In view of the deductions from the craft workers, the significance of engineering information was observed to be more critical in a study by Naoum (2016), who did a survey with 36 construction firms in order to identify 46 factors affecting construction labor productivity. The delay caused by design error and change orders were ranked second while communication systems were ranked third. Additionally, the lack of integration of the management information systems

for the projects was ranked ninth overall. The same pattern was observed in another similar survey by Dai et al. (2009a) with approximately 2,000 craft workers as participants; 40 percent of the study participants worked in the piping and electrical trades. The survey results show that three among the ten most important issues in Dai's study revolved around the availability and accuracy of engineering drawings. In addition, the absence of well engineering information influences craft productivity. O'Connor (1985) reported that the lack of well-conveyed information to crafts results in productivity decline.

The previous findings identified the importance of engineering information deliverables on crafts' performance. Adjustments in the acts of providing construction crafts of the engineering drawing are indispensable to enhance crafts performance. Moreover, understanding how individual craft workers access, view or interpret the information they need to perform their tasks is a basic gap in the current body that the research effort described herein.

2.3 Formats of Engineering Deliverables

2.3.1 Two-Dimensional Drawings (2D)

Two-dimensional plan sets are the main format of engineering deliverables at the construction workface. According to Barr and Juricic (1994), the utilization of the 2D drawings has been present in the construction industry for the past few decades. However, the last noteworthy change in 2D drawings happened in 1795 when French mathematician Gaspard Monge published *Geometries Descriptive* demonstrating that every single spatial issue can be addressed graphically utilizing two or more projection planes. The modern information system still uses the descriptive geometry as the basis for displaying the same 3D object in multiple 2D views. Bowden et al. (2006) argue that paper-based plans and files are the essential formats for engineering deliverables. Furthermore, in the construction industry, a project detailed technical information is typically

provided to construction craft in the form of 2D drawings to permit them to undertake their tasks (Emmitt and Gorse 2003).

2.3.2 Isometric Drawing

Isometrics drawings are a types of 2D drawings that give basic technical graphical and textual facts required to support construction installations. Isometric drawings are 2D images that have horizontal lines at 30° horizontally, but are vertically fixed to take into account directional distinction of the design's geometric properties. These drawings are normally not drawn to scale so they show proportional measurements rather than actual differences in scale. The lack of scale allows ample space on the drawing for text, which includes dimensions and comments that support additional design details. The isometric format requires that craft workers must read both the drawing and text to visualize an accurate 3D image of the item. In the recent past, isometric engineering drawings have acted as the primary information format given to sheet metal, electrical, plumbing, and pipefitting craft workers. Therefore, pipefitters are commonly issued with work packages, which a series of isometrics that make the whole assembly. The work packages comprise joints specifications, material quantities and brief statements on the information required to support a particular assembly. Dadi (2014a) states that specific isometric drawings show a single pipe spool and in order to assemble the spools together; annotations are used to indicate the adjacent spools.

2.3.3 3D Computer Aided Design (CAD)

3D CAD become common in design offices and other related adaptation of the procedures on site since the 1980's period (Encarnaçao et al. 1990). The Architects' Journal, the New Engineer, and Construction News publications voted 3D CAD as the most developed in the construction sector through interviewing several prominent leaders in the industry (Wynne, 2012). In addition,

it has permitted engineers to design and construct more complex structures. Notably, the fundamental advantages of 3D CAD were observed to be the streamlined reuse and revision of drawings, planning of construction sequencing and techniques, designing site layouts, and in the coordination of the subcontractors (Mahoney and Tatum, 1994). Today, 3D CAD is obviously an unavoidable tool in the construction industry.

2.3.4 Building Information Modeling (BIM)

BIM is a form or digital representation of a physical and functional characteristics of a facility (The US National Building Information Model Standard Project Committee, 2016). 3D CAD in the architectural, engineering, and construction industries has evolved into integrated BIM, which is defined as models that contain graphical, data, and behavioral attributes, consistent and non-redundant, and coordinated data between platforms and trades (Eastman, 2008). BIM can be seen as a way toward the creation and the management of building information in an interchangeable and recyclable form (Shen & Chua, 2011). Eastman (2008) also described BIM as one system or several systems that allow users to incorporate and reuse construction information and domain knowledge in the building's lifespan. The software that uses BIM technology usually has a broader coverage compared to the three dimensions. The application of BIM allows users to work with time (fourth dimensions) and cost (fifth dimension) thereby ensuring field planning, estimation of costs as well as tracking construction progress along with a 3D referenced model. In addition, BIM is an enabling technology that reduces the fragmentations that face the construction industry when using a single 3D geometric model (Azhar, 2011). Goodrum and Miller (2015) agreed with this assessment, but the direct access and application of BIM at the construction workforce with the end goal of enhancing engineering deliverables is still not common.

2.3.5 *Physical Scaled 3D Models*

Physical models allow visualization of information about any item that is represented in the model. In the construction industry, physical scale models consist of the entire project or individual elements built to scale. Physical models were earlier utilized as planning and communication tools (Ogelsby et al., 1989). Conventionally, 3D scale models were made by hand and were costly to build and maintain (Goodrum & Miller 2015). Modern 3D printers are capable of creating 3D scale models more efficiently. However, Mahoney and Tatum (1994) identified how the present level of technological advancement and the introduction of 3D CAD technologies, in particular, caused the use of physical 3D models to decline.

Although 3D scale models are infrequently utilized on construction job sites today, full-scale models, called mock walls, are still utilized, as a way of illustrating the final design elements to owners and construction specialists. This is particularly true in the commercial building sector. While there may be potential uses for 3D physical scale models in the construction field, the transformation of a 3D CAD or BIM model to an appropriate format for 3D printing requires extensive redesigning to fulfill the current 3D printing file format (Goodrum & Miller 2015). Thus, the use of 3D scale models by construction crews remains uncommon.

2.4 Previous Construction Research Designs

This paper's design builds on the studies of Dadi et al., (2014a, 2014b, and 2014c), Sweany et al., (2016), and Goodrum et al., (2016). Dadi et al. (2014a) inspected the cognitive loads of 26 participants utilizing 2D plan drawings, 3D CAD drawings, and 3D printed models to build scale model assemblies. The NASA-rTLX test was applied after every assembly to quantify the cognitive load of the task. 3D printed models were found to have the lowest mental load on average (Dadi et al. 2014a). However, the ANOVA analysis for NASAr-TLX measures indicated that

results were statistically insignificant. The participants who referenced engineering drawings at least once in a day experienced a 35% lower cognitive load in the assemblies (Dadi et al. 2014a). The results indicate a negative relationship among the formal training and cognitive load in workers and possibility of improving their performances. In relation to experience, more experience would be expected to lower the mental load demand, but Dadi et al. reported that the assemblers with the least experience had a 16% lower mental load demand (2014a). Furthermore, while Dadi et al. (2014a) reported a relationship between the format of information and task efficiency, using either 3D CAD drawings or 3D printed models did not always correspond to significant changes in time to completion, direct and indirect work, or installation errors (Dadi et al. 2014b, 2014c).

Sweany et al. (2016) applied a different sampling plan and identified a statistically significant relationship between information format and performance. In the study, three structural assemblies in the form of a 2D plan set, a 3D CAD model on a digital device, and a 3D physical print were given to construction field supervisors. In each structural assembly, different formats of information were used to control the effects of a learning curve. Task performance was measured through time to complete the assembly, number of installation errors, direct indirect work rates. The results show that when participants used the 2D plan set they performed worst as compared to using either the 3D CAD model or the 3D physical print. Sweany et al., (2016) additionally found that the relationship between improved performance and the 3D information format was supported when contrasts in spatial cognition were controlled.

Finally, Goodrum et al. (2016) examined pipefitters in the U.S and Canada to investigate how spatial cognition impacted their performance on scale model assembly tasks. The participants were given one of three engineering information formats, 2D isometric drawings, 2D isometric drawings

improved with a 3D image of the assembly, and 2D isometric drawings improved with a 3D physical print model. The experimental formats were chosen after focusing on six focus groups in Ontario, Louisiana, Texas and Utah. The results indicated that those who used the 2D isometric drawings with the 3D physical model exhibited good performance in three of the four performance metrics—number of errors, direct work, and indirect work. However, those who used the 2D isometric drawings improved with a 3D image of the assembly were the fastest in completing the assembly. Additionally, Goodrum et al. (2016) measured participants' spatial cognition using the card rotation and cube comparison tests. Their results indicated that when 2D information was given, participants with low scores in spatial cognition tests performed significantly worse compared to participants with high spatial cognition scores. When the 2D isometric drawings were improved with 3D information, participants with lower spatial cognition completed the model assembly as productively and effectively as participants with higher spatial cognition. The 3D physical model was excluded in their study because of sample size limitations.

Limitations of the previous studies (Dadi et al., 2014 a, b, c; Sweany et al., 2016; and Goodrum et al., 2016) have led to the current need for additional research. The weakness of those studies was that model designs were moderately straightforward. This was necessary because time restrictions for conducting the experiments meant that tests were limited to 30 minutes. Additionally, time was limited because the experiments were conducted during normal work hours, when each participant was being paid by their employer. Since the simplicity of the designs limited the potential for confusion, rework, and mistakes, this led to reduced variance in the performance metrics. However, in this study, participants are paid for one hour of their time with a specific end goal of allowing us to use more complex designs. We use three designs with various complexities (simple, medium, and complex designs) to analyze whether greater returns in

performance are realized from increased complexity. Despite the fact that essential and statistical differences based on types of engineering information were observed, more complex designs are justified to more thoroughly examine contributory components, such as age, work experience, training, and other demographic qualities. Similarly, larger sample sizes permit the utilization of more advanced statistical methods. This paper focuses on the influence of engineering information format and increasing design complexity on worker performance. Due to the limited scope of this paper, other potential issues, such as the effect of demographics, spatial cognition and fixation patterns on performance, will be addressed in subsequent papers. This paper is guided several hypothesis including:

- H1: Different formats of information influence task performance differently;
- H2: The influence of different information formats on task performance become stronger when increasing design complexity; and
- H3: Different types of 3D information influence similarly in task performance.

2.5 Methodology

The study relied on empirical data collection methods and quantitative analysis to examine how various design complexity and the use of different engineering information formats influence performance in a task execution. The following sections go into more details regarding the study's research methods.

2.5.1 Task Design

This paper involves developing models of scaled piping works with different design complexities and different formats. The development of the task designs were based on the Goodrum et al. (2016) study. In order to examine how design complexity and information format

influence experimental outcomes, three piping designs were developed (simple, medium and complex). The piping design and the data from Goodrum's et al. (2016) study were used in this research for the simple design.

The level of complexity of each design was identified based on research by Wood (1986) that defines design complexity using three dimensions: component, coordinative, and dynamic. Component complexity of a task refers to the number of different components that need to be completed in the performance of the task and the amount of information that must be addressed. Coordinative complexity refers to the relationships between task components. The difficulty for coordination increases when the requirements of timing, frequency, intensity, and location of the components become more complex. Dynamic complexity is caused by changes in the relationship between task-related input and output over time. Therefore, the complexity of any design depends on the number of the components and the relationship between its components. In this study, five categories have been used to create and determine the level of complexity between the three proposed piping designs, these five categories include:

- Number of pipe pieces in each design;
 - Number of elbows (a type of pipe fitting intended to join pipe pieces at an angle);
 - Number of pipe tees (a type of pipe fitting used to join two or more pipes);
 - Number of slopes (a piece of pipe that has one side at a higher level than the other);
- and
- Number of spools. (a spool is an isometric sheet that contains an assembly drawing of pipes and components; a series of spools comprise an entire assembly design).

Table 2.1 shows the proposed piping model designs that vary in complexity based on the previous five categories.

Table 2.1. Proposed Piping Models

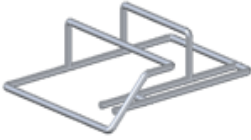
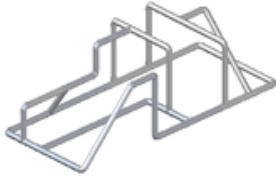
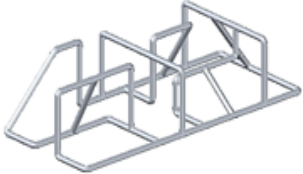





	Design 1 (Simple)	Design 2 (Medium)	Design 3 (Complex)
			
No. of Pipes	19	34	46
No. of Elbows	9	16	22
No. of Tees	6	12	16
No. of Slopes	1	3	5
No. of Spools	4	7	10

For each design, three engineering information formats were developed which include:

- A 10-sheet set of Traditional, 2D isometric drawings;
- A 10-sheet set of 2D isometric drawings with a 3D image of the assembly; and
- A 10-sheet set of 2D isometric drawings with a 3D physical print of the assembly.

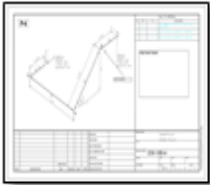
The information formats lead to the same assembly of each design; they are just different ways to deliver the information. Table 2.2 shows the three piping designs and their information formats as well the first sheet from each information format.

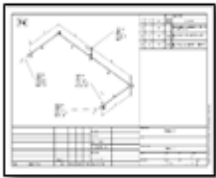
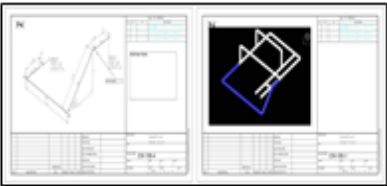
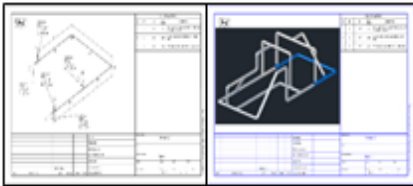
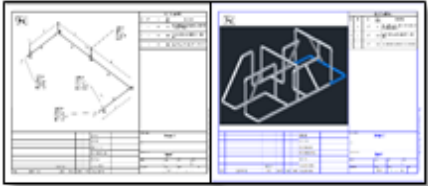
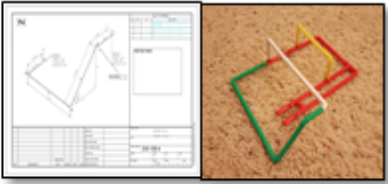
Table 2.2. The three Piping Designs and their Information Formats.

Design Format	Design 1: Simple 	Design 2: Medium 	Design 3: Complex 
2D Isometric Drawings	 (1 of 4 sheets)	 (1 of 7 sheets)	 (1 of 10 sheets)
2D Isometric Drawings + 3D image	 (1 of 4 sheets)	 (1 of 7 sheets)	 (1 of 10 sheets)
2D Isometric Drawings + 3D Physical Model	 (1 of 4 sheets)	 (1 of 7 sheets)	 (1 of 10 sheets)

2.5.2 Baseline Testing

The level of complexity of each design was based on the previous five categories. However, in order to ensure the consistency of the levels of difficulty among the designs, a baseline test was performed in which the information medium was held constant in each design. The second format from each design, which is the 2D isometric drawing supplemented with a 3D image of the assembly, was used in the baseline test. Nine graduate students from the University of Colorado at Boulder were recruited to serve as subjects to gather preliminary empirical evidence on the difficulty level of each design assembly.

Four performance metrics were used to identify if there are difficulty levels of the three designs. A 30-second intervals was used to observe the participants as they assemble their models. Based on the video recordings, each 30-second interval was assigned to one of three categories: direct work, indirect work, or rework time. Direct work is the physical act of installing pieces, or measuring pieces in order to assemble the model (i.e., handling the PVC pipe, measuring, and joining the pieces). Indirect work the act of reading plans, visualizing how the model is to be assembled, or any other act that is not Direct Work or Rework (e.g., mentally conceptualizing the model). Rework time is the act of removing any piece that has already been assembled, or reinstalling a piece. The sum of the categories results in the total time each participant takes to assemble the model. Optimal use of time will be considered as low indirect work and high direct work times. The averages for each metric are illustrated in Table 2.3. High performance on an assembly would result in a high percentage for direct work and low for indirect work, rework, and time to completion.

Table 2.3. Baseline testing Average Results for each Design using 2D Isometric with a 3D Image.

Design	Sample Size	Time to Completion (m:s)	Direct Work (%)	Indirect Work (%)	Rework (%)
Simple	9	8:59	69.25%	24.67%	6.08%
Medium	9	14:28	52.65%	38.65%	8.70%
Complex	9	16:26	55.95%	37.87%	6.18%

An ANOVA analysis was performed to determine if the three designs had any statistically significant effect on the collected data. The results in Table 2.4 confirm that there were statistical differences between the simple and medium designs in most of the performance measurements except the rework. Based on these results, the level of difficulty of the simple and medium designs was determined to be different, which means the medium design is more difficult than the simple design. Therefore, the designs can be used in the larger field trials as simple and medium designs.

Table 2.4. Performance Metrics by the Simple and Medium Designs.

Metric	Design	Sample Size	Mean	Overall Mean	F	p
Time to Completion	Simple	9	08:59	11:43	17.01	.001
	Medium	9	14:28			
Direct Work	Simple	9	69.25%	60.95%	27.00	.000
	Medium	9	52.65%			
Indirect Work	Simple	9	24.67%	31.66%	31.22	.000
	Medium	9	38.65%			
Rework	Simple	9	6.08%	7.44%	2.48	.135
	Medium	9	8.70%			

Table 2.5 confirms that there were no statistical differences between the medium and complex designs for any of the performance measurements, since all the p-values are greater than 0.05. Based on these results, the levels of difficulty of the medium and complex designs were determined

to be similar. Therefore, adjustments were needed in the complex design to make it more difficult than the medium design.

Table 2.5. Performance Metrics by the Medium and Complex Designs.

Metric	Design	Sample Size	Mean	Overall Mean	F	p
Time to Completion	Medium	9	14:28	15:27	1.68	.213
	Complex	9	16:26			
Direct Work	Medium	9	52.65%	54.38%	1.70	.211
	Complex	9	55.95%			
Indirect Work	Medium	9	38.65%	38.16%	0.11	.735
	Complex	9	37.87%			
Rework	Medium	9	8.70%	7.5%	1.70	.210
	Complex	9	6.18%			

In order to make the complex design more difficult than the medium design, adjustments were made in the complex model. More pipe pieces were added, including elbows and tees in different elevations. Figure 2.1 shows the complex design model before and after the changes. The red section represents the new pieces that were added to the model.

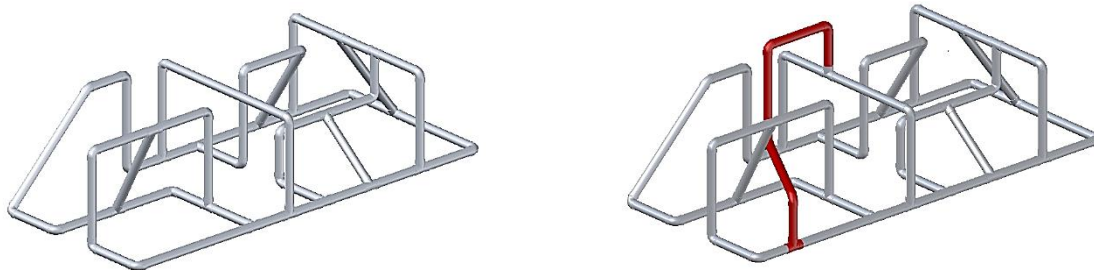

Figure 2.1. The Complex Design Model before and after the Adjustments.

The results in Table 2.6 confirm that, after changes were made, there were statistical differences between the medium design and the complex design for most of the performance measurements, since all the p-values are less than 0.05 except for rework. Based on these results,

the levels of difficulty of the medium design and the complex design (after changes) were determined to be different. The new complex design is more difficult than the medium design; therefore, it can be used in the larger field trials as a complex design.

Table 2.6. Performance Metrics by the Medium Design and the Complex Design (After Changes)

Metric	Design	Sample Size	Mean	Overall Mean	F	p
Time to Completion	Medium	9	14:28	20:25	32.17	.000
	Complex after changes	8	27:07			
Direct Work	Medium	9	52.77%	48.88%	15.42	.001
	Complex after changes	8	43.87%			
Indirect Work	Medium	9	38.55%	41.41%	8.47	.011
	Complex after changes	8	44.62%			
Rework	Medium	9	8.77%	10.17	1.48	.241
	Complex after changes	8	11.75%			

2.5.3 Field Trials

2.5.3.1 Participants

All of the field trial participants were construction workers from the MEP trades. Limiting the participants to MEP trades is intentional for three reasons. First, isometric drawings are the primary information format provided to MEP trades. Second, isometrics are one of the most complex information formats provided to all construction-related trades, since the material involves engineered components that must be assembled in a specific order. Third, the MEP trades constitute the largest percentage of direct craft labor and are responsible for a high percentage of material costs on most commercial and industrial projects. As such, the potential for improvement and the impact on industry practice is significant. The study utilized a total of 161 MEP workers from industrial jobsites in the U.S. and Canada, with most of the participants being member of

local pipefitter union chapters in the Colorado Front Range. The participants ranged in age from 18 to 65. Their years of industry experience ranged from 0 to 47 years.

2.5.3.2 Experiment Method

All field trials were conducted in an office setting on jobsites or a training centers. Each trial involved a single participant from an MEP trade, and each participant used one design and one of the three information formats to guide the assembly of a 1:12 scale model of a piping module (Fig. 2.2). The tasks included reading the plan, measuring pipe lengths, joining pipe members to create spools, and assembling the spools to complete the model. The pipe was 12.5 mm ($\frac{1}{2}$ in.) diameter polyvinyl chloride (PVC). No welding or pipe bending was required. All field trials were video recorded for analysis purpose.

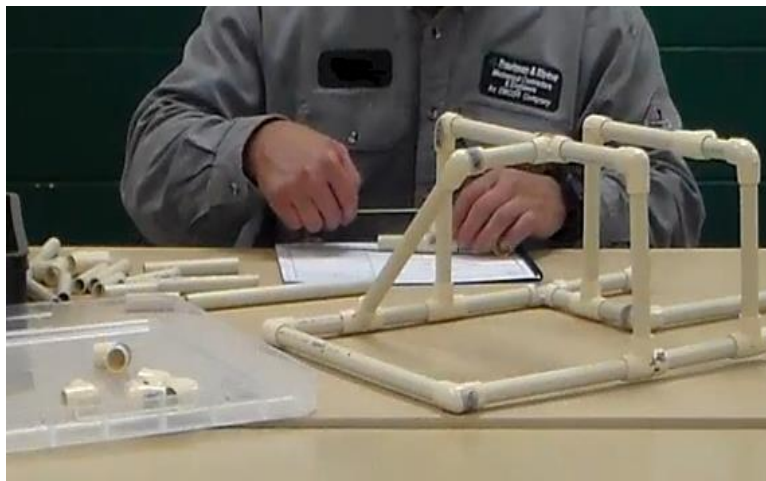

Figure 2.2. Field Trial Experiment

2.5.3.3 Experiment Metrics

To evaluate the performance in each experiment, participants were observed at 30-second intervals. Based on the video, each 30-second interval was assigned to one of three categories; direct work, indirect work, and rework.

- Direct Work: the physical act of installing pieces, or measuring pieces in order to assemble the model (i.e., handling the PVC pipe, measuring, and joining the pieces).
- Indirect Work: the act of reading plans, visualizing how the model is to be assembled, or any other act that is not Direct Work or Rework (e.g., mentally conceptualizing the model).
- Rework: the act of removing any piece that has already been assembled, or reinstalling a piece.

The sum of the categories results in the total time that each participant took to assemble the model (Time to Completion). In addition, the number of errors were counted at the end of each experiment.

2.6 Field Trial Results

2.6.1 Effects of Information Format in each Design

The results of the field trials, organized by design and information format, are shown in Table 2.7. An ANOVA analysis was performed to statistically validate the observed influence that the information type had on each performance metric (i.e., time to completion, error occurrence, direct work, and indirect work) in each design. The significance of each performance measure is described by the F-score and the p-value. The F-score is the variance of the group mean. The p-value indicates the significance level of the mean score and the degree of confidence to which that statistic holds, where p-values less than 0.10 yield a confidence of 90% and values less than 0.05 yield a confidence of 95% or greater.

Table 2.7 indicates that there is statistical significance among the mean performance scores beyond 95% confidence. By looking to time to completion and number of errors, the 2D isometric plus 3D image and the 2D isometric plus 3D physical model performed significantly better than the 2D Isometric format in all designs, the significant level (p value) increased while the design complexity increased. The 2D isometric plus 3D image and the 2D isometric plus 3D physical

model also performed significantly better than the 2D Isometric in direct and indirect work in all designs with more significant level (p value) in the medium and complex designs. There was no statistical significance in re-work metric in the simple design, while the 2D isometric plus 3D image and the 2D isometric plus 3D physical model performed significantly better than the 2D Isometric in re-work, with more significant level (p value) in the complex design.

Figures 2.3-2.7 show the average measures of all five performance metrics by information type in each design. Overall, when the 2D isometric format plus 3D image and 3D physical model were tested against the 2D isometric format, the performance across all metrics gradually improved as design complexity increased.

Table 2.7. Performance Metrics by Information Format for each Design.

Performance	Info. Format	Design 1 "Simple Design"				Design 2 "Medium Design"				Design 3 "Complex Design"			
		N	Mean	F	P	N	Mean	F	P	N	Mean	F	P
Total Time (minute:sec)	2D Isometric	23	0:11:31	2.75	0.07	12	0:22:25	3.30	0.05	19	0:38:54	11.08	0.00
	2D Isometric + 3D Image	21	0:09:40			13	0:16:56			20	0:26:49		
	2D Isometric + 3D Physical	15	0:09:45			14	0:18:17			20	0:27:36		
Direct Work %	2D Isometric	24	63.04	5.48	0.01	13	52.22	9.14	0.00	20	48.26	27.81	0.00
	2D Isometric + 3D Image	21	72.46			14	68.50			20	70.01		
	2D Isometric + 3D Physical	15	76.64			14	67.02			20	65.40		
Indirect Work %	2D Isometric	24	32.88	5.21	0.01	13	39.84	8.49	0.00	20	42.87	23.52	0.00
	2D Isometric + 3D Image	21	23.67			14	27.37			20	26.14		
	2D Isometric + 3D Physical	15	21.51			14	29.26			20	30.42		
Re-work %	2D Isometric	23	4.08	1.65	0.20	13	7.93	3.54	0.04	20	8.87	12.26	0.00
	2D Isometric + 3D Image	21	3.95			14	4.13			20	3.76		
	2D Isometric + 3D Physical	13	1.86			14	3.72			20	4.18		
# Errors	2D Isometric	24	0.58	2.96	0.06	13	0.85	3.23	0.05	20	1.20	8.32	0.00
	2D Isometric + 3D Image	21	0.29			14	0.36			20	0.30		
	2D Isometric + 3D Physical	15	0.07			14	0.21			20	0.25		

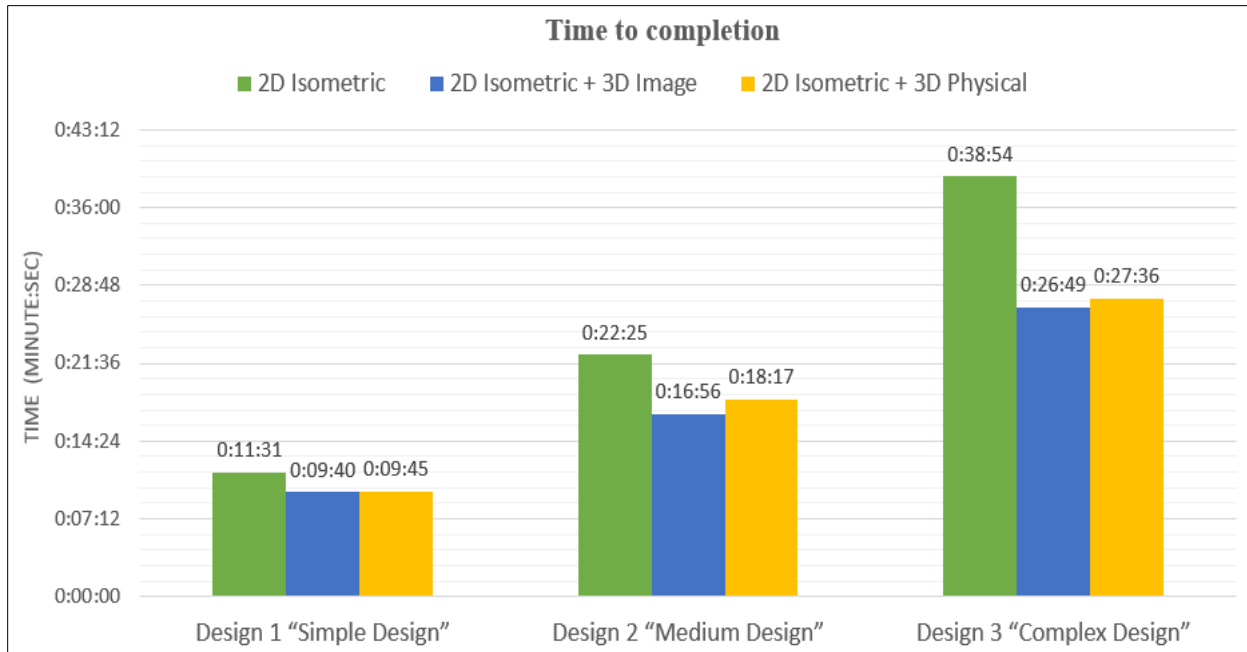

Figure 2.3. Average Total Time by Information Format in each Design.

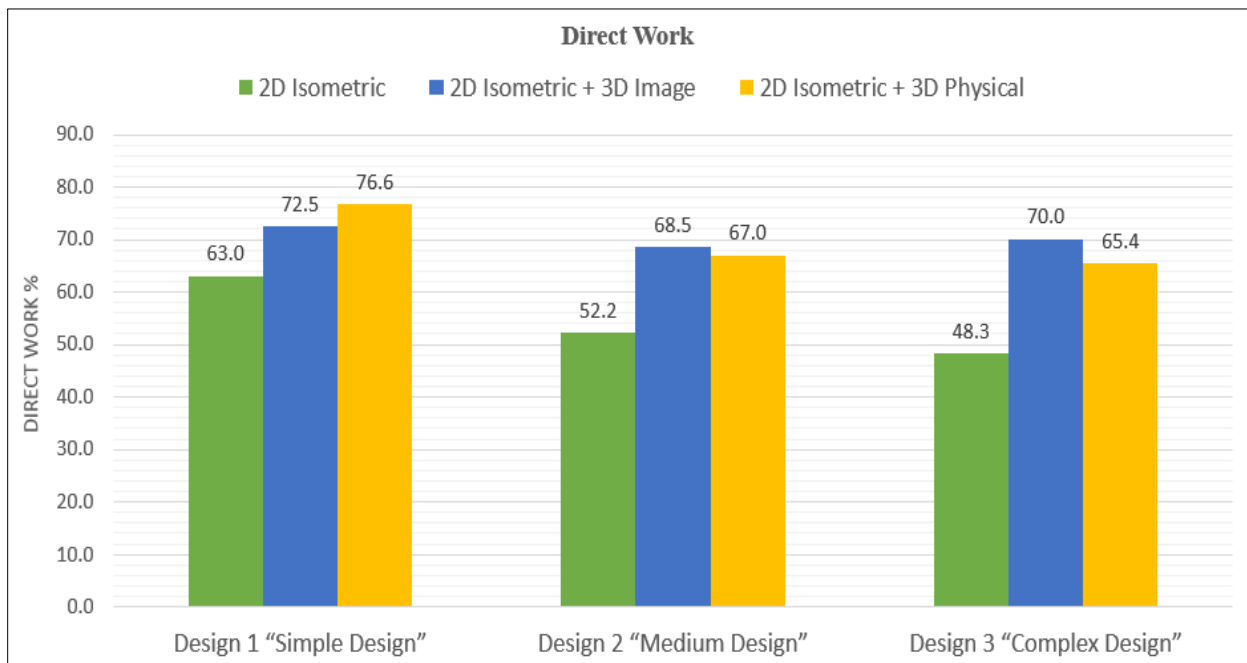

Figure 2.4. Direct Work by Information Format in each Design.

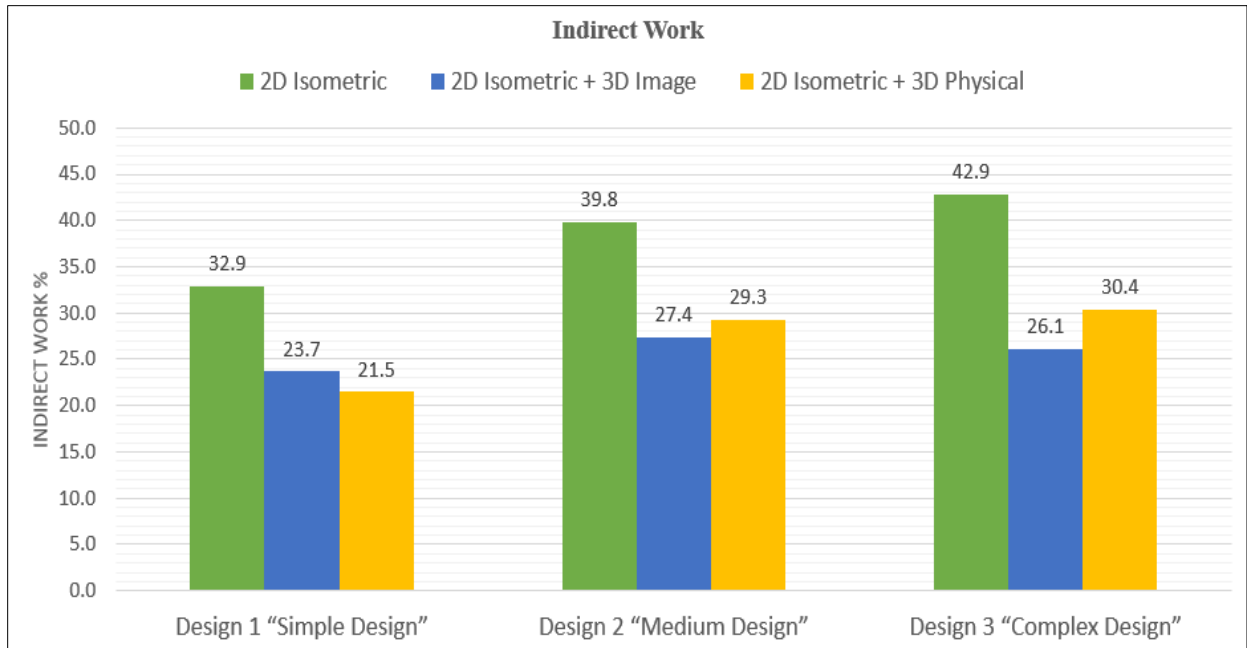

Figure 2.5. Indirect Work by Information Format in each Design.

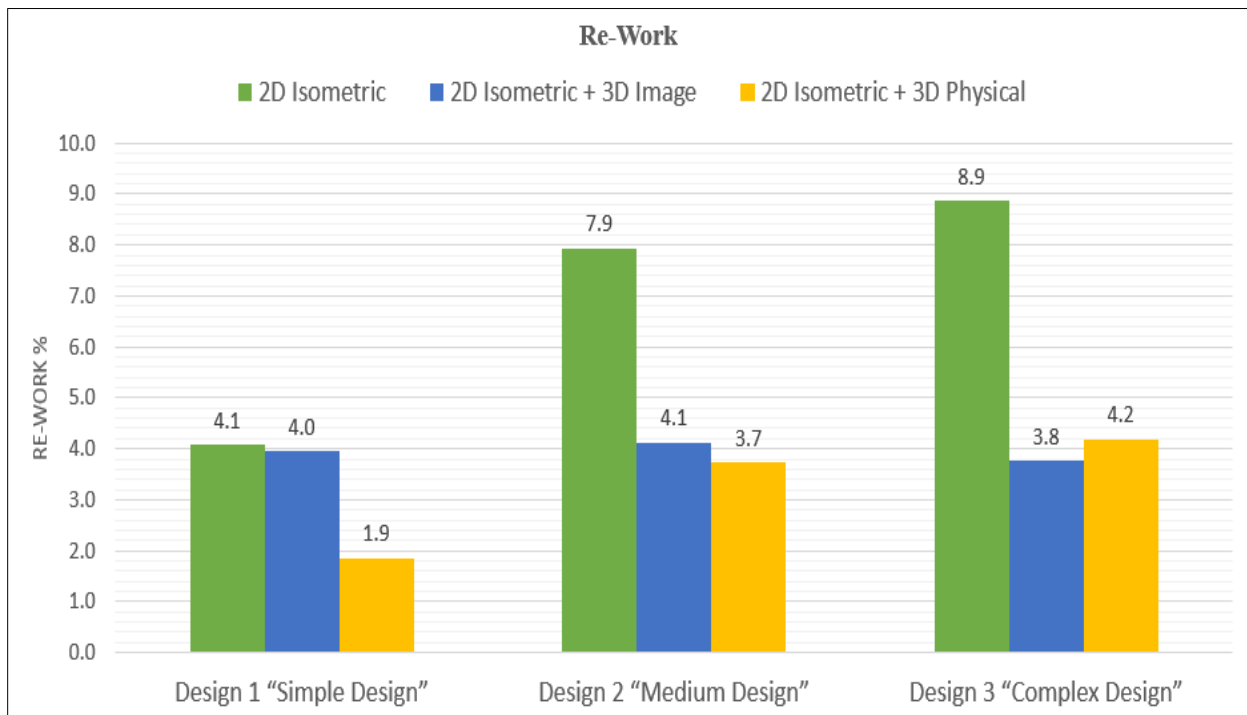

Figure 2.6. Re-work by Information Format in each Design.

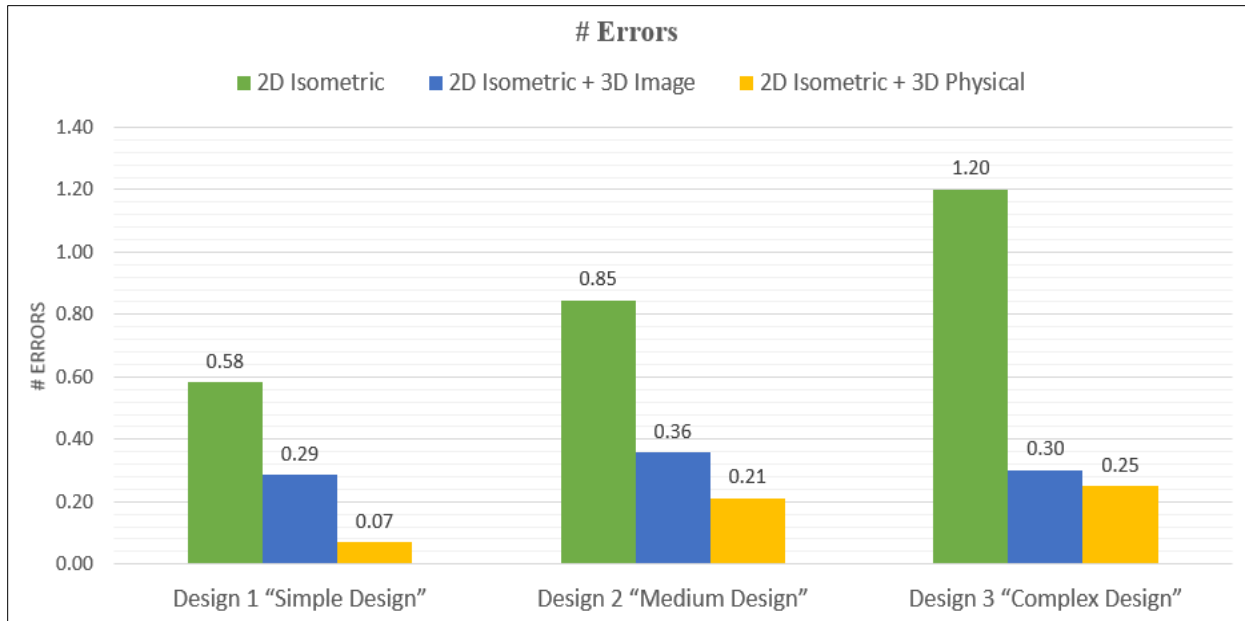

Figure 2.7. Number of Errors by Information Format in each Design.

2.6.2 Comparing the Effects of 3D Information Formats

An ANOVA analysis was performed to compare craft workers performance when using the 2D isometric plus 3D image and the 2D isometric plus 3D physical model in each design. Based on the results, different types of 3D information led to almost the same results in task performance. Table 2.8 confirms that there were no statistical differences between the two types of 3D information in most of the performance measurements, except the direct and indirect work in the complex design. Craft workers using the 2D isometric plus a 3D image format performed significantly better in terms of direct and indirect work rates than those who used the 2D isometric format plus a 3D physical model. This is because with the 3D physical model, craft workers took a long time (indirect work) looking at the physical model to adjust its orientation in order to be the same as the orientation of the 2D isometric sheets. In contrast in using the 2D isometric plus a 3D image format, craft workers were able to coordinate a set of drawings through the plan north arrow that was placed on both the 2D isometric and 3D image sheets.

Table 2.8. Performance Metrics by 3D Information Format for each Design.

Performance	Info. Format	Design 1 "Simple Design"				Design 2 "Medium Design"				Design 3 "Complex Design"			
		N	Mean	F	P	N	Mean	F	P	N	Mean	F	P
Total Time (minute:sec)	2D Isometric + 3D Image	21	0:09:40	0.01	0.92	13	0:16:56	0.52	0.48	20	0:26:49	0.11	0.74
	2D Isometric + 3D Physical	15	0:09:45			14	0:18:17			20	0:27:36		
Direct Work %	2D Isometric + 3D Image	21	72.46	1.76	0.19	14	68.50	0.17	0.69	20	70.10	3.84	0.06
	2D Isometric + 3D Physical	15	76.64			14	67.02			20	65.40		
Indirect Work %	2D Isometric + 3D Image	21	23.67	0.48	0.49	14	27.37	0.45	0.51	20	26.14	3.54	0.07
	2D Isometric + 3D Physical	15	21.51			14	29.26			20	30.42		
Re-work %	2D Isometric + 3D Image	21	3.95	2.97	0.10	14	4.13	0.09	0.77	20	3.76	0.36	0.55
	2D Isometric + 3D Physical	15	1.86			14	3.72			20	4.18		
# Errors	2D Isometric + 3D Image	21	0.29	1.55	0.22	14	0.36	0.67	0.42	20	0.30	0.10	0.76
	2D Isometric + 3D Physical	15	0.07			14	0.21			20	0.25		

2.7 Limitations

The limitation of this paper is the scale of the model assembly task. Pipe used on most industrial projects is often 152.4 mm (6 in.) in diameter or larger, which is significantly larger than the 12.7 mm (0.5 in.) PVC pipe used in this study. While fitting pipe requires more tasks (e.g., welding, material and equipment handling, and bolting), this research model focused only on measuring and assembling pipe through using engineering drawings, usually isometrics, to erect complex assemblies. In addition, construction sites are dynamic environments with numerous factors affecting craft workers' performance, such as information, equipment, tools, materials, rework, supervision, congestion, safety, weather, sequencing, individual skills of workers, size of components, specification, work content, design features, and work scope (Thomas and Sakarcan 1994). The authors readily acknowledge that these and other jobsite factors would likely influence results, if the field trials were conducted on a construction worksite versus being conducted in a controlled setting.

2.8 Conclusion

Building upon research conducted by Dadi et al. (2014), Sweany et al (2016), and Goodrum et al. (2016), this study utilizes field data to find new correlations between engineering information formats and designs complexity level. A list of statistically proven trends is available in Table 2.9. The primary contribution from this study to the body of knowledge is the strong statistical significance found between the level of design complexity and the format of engineering information. The results in this study indicate that as design complexity increased, the effects of using different engineering information formats increased. This increase is most likely due to reduction of analysis to interpret 3D images and physical models as opposed to 2D isometric drawings. The trial participants performed the best when using either the 2D isometric format plus 3D image or the 2D isometric format plus 3D physical model and the worst when using the 2D isometric format across all metrics in the three designs, supported by statistical significances that increased when design complexity increased.

Table 2.9. Trends Statistically Proven.

Number	Hypothesis	Result
1	Different formats of engineering information influence task performance differently.	Participants performed the best when using either the 2D isometric format plus 3D image or the 2D isometric format plus 3D physical model and the worst when using the 2D isometric format.
2	The influence of different information formats on task performance become stronger when increasing design complexity.	When design complexity increases, the effects of using different engineering information formats increases, and that supported by statistical significances.
3	Different types of 3D information influence similarly in task performance.	Participants who used the 2D isometric with 3D CAD image performed almost same as those who used the 2D isometric with 3D physical model.

Even though this research was conducted in a controlled setting with scaled piping models, the results reveal that as design complexity increased, the effects of using different engineering information formats increased. Therefore, since construction sites have more complex tasks, if the field trials had been conducted on an actual construction project, engineering information formats would likely have influenced the craft workers' performance.

Realistically, while most construction companies may be primarily concerned with worker productivity, the format of engineering information greatly affects their performance. Companies that invest in preparing engineering deliverables for complex tasks have the capability to significantly improve the performance of their craft workers.

References

- Azhar, S. (2011). Building Information Modeling (BIM): “Trends, Benefits, Risks and Challenges for the AEC Industry”. *Leadership and Management in Engineering*, 11, pp 241-252, American Society of Civil Engineers.
- Barr, R.E. & Juricic, D. (1994) “From Drafting to Modern Design Representation: The Evolution of Engineering Design Graphics”, *Journal of Engineering Education*, July 1994, pp 263-270.
- Bowden, S., Dorr, A., Thorpe, A., Anumba, C. (2006). “Mobile ICT Support for Construction Process Improvement”. *Automation in Construction* Vol. 15 (5). 664–676.
- Dadi, G. B., Goodrum, P. M., Taylor, T. R., and Carswell, C. M. (2014a). “Cognitive Workload Demands Using 2D and 3D Spatial Engineering Information Formats”. *Journal of Construction Engineering and Management*, 140(5).
- Dadi, G. B., Goodrum, P. M., Taylor, T. R., & Maloney, W. F. (2014b). “Effectiveness of communication of spatial engineering information through 3D CAD and 3D printed models”. *Visualization in Engineering*, 2(1), 1-12.
- Dadi, G. B., Taylor, T. R., Goodrum, P. M., & Maloney, W. F. (2014c). “Performance of 3D computers and 3D printed models as a fundamental means for spatial engineering information visualization”. *Canadian Journal of Civil Engineering*, 41(10), 869-877.
- Dai, J., Goodrum, P. M., and Maloney, W. F. (2009a).”Construction Craft Worker' Perceptions of the Factors Affecting Their Productivity”. *Journal of Construction Engineering and Management*, (135), 217–226.
- Eastman, C., M. (2008). BIM handbook: “A guide to building information modeling for owners, managers, designers, engineers, and contractors”. *Hoboken, New Jersey: Wiley*
- Emmitt, S. and Gorse, C. (2003). “Construction Communication”. *Blackwell Publishing, Oxford*.
- Encarnaçao, J. L., Lindner, R., Schlechtendahl E. G., (1990) “Computer Aided Design, Fundamentals and System Architectures.” *Springer Berlin Heidelberg*.
- Goodrum, P. M., and Miller, J. M. (2015). “Innovative delivery methods of information to the crafts. Construction Industry Institute”, *Univ. of Texas at Austin, Austin, TX. RT 327*.
- Goodrum, P., Miller, J., Sweany, J., and Alruwaythi, O. (2016). “Influence of the Format of Engineering Information and Spatial Cognition on Craft-Worker Performance”. *Journal of Construction Engineering and Management*, Vol. 142, No. 9.

- Gouett, M., Haas, C., Goodrum, P., and Caldas, C. (2011). "Activity analysis for direct-work rate improvement in construction". *ASCE Journal of Construction Engineering and Management*, 37: 1117-1124.
- Liberda, M., Ruwanpura, J., & Jergeas, G. (2003). "Construction Productivity Improvement: A Study of Human, Management and External Issues". ASCE. *Construction Research Congress*. 1-8. 10.1061/40671(2003)5.
- Mahoney, J. and Tatum, C. B. (1994). "Construction Site Application of CAD". *Journal of Construction Engineering and Management*, 120, pp 617-631.
- Naoum, S. G., (2016). "Factors influencing labor productivity on construction sites: A state of the art literature review and a survey". *International Journal of Productivity and Performance Management*. ISSN: 1741-0401
- O'Connor, J. T. (1985). "Impacts of Constructability Improvement". *ASCE Journal of Construction Engineering and Management*, (111) 404-410.
- Ogelsby, C. H., Parker, H. W., and Howell, G. A. (1989). "Productivity improvement in construction." *McGraw-Hill*, New York.
- Shen, L, Chua, D.K.H., (2011). "Application of Building Information Modelling (BIM) and Information Technology (IT) for Project Collaboration". EPPM, Singapore, 20-21 Sep 2011
- Sweany, J., Goodrum, P., Miller, J. (2016). "Analysis of empirical data on the effects of the format of engineering deliverables on craft performance". *Automation in Construction*, Volume 69. (2016) 59-67
- The US National Building Information Model Standard Project Committee, Frequently Asked Questions about the National BIM Standard-United States, <https://www.nationalbimstandard.org/faqs#faq1>, (August. 22, 2016).
- Thomas, R., and Sakarcan, A. S. (1994). "Forecasting labor productivity using factor model". *Journal of Construction Engineering and Management*. 10.1061/ (ASCE) 0733 9364(1994)120:1(228), 228-239.
- Wood, R. E. (1986). "Task complexity: Definition of the construct." *Organizational Behavior and Human Decision Processes*, 37: 60-82.
- Wynne, A. (2012, December 5). "CAD - The Greatest Advancement in Construction History". Retrieved from The Architect's Journal: <https://www.architectsjournal.co.uk/cad-the-greatest-advance-in-construction-history/1996442.article>

CHAPTER 3: THE RELATIONSHIP BETWEEN ENGINEERING INFORMATION FORMAT, SPATIAL COGNITION, AND DEMOGRAPHICS IN CRAFT WORKER PERFORMANCE

3.1 Abstract

The quality and fluency of engineering information delivery is critical to craft success in the construction industry. Advancements in three-dimensional (3D) computer aided design (CAD), augmented reality, virtual reality, and 3D printing provide new format options to deliver engineering information. However, providing them to crafts for use at the construction workforce remains relatively rare. A series of field trials with mechanical, electrical, and plumbing (MEP) workers was conducted to examine the influence that their spatial cognition, demographics and the format of information have on their performance in building a scale model task assembly. Participants were provided one of three information formats: two-dimensional (2D) isometric drawings, 2D isometric drawings supplemented with a three-dimensional (3D) image of the assembly, and 2D isometric drawings supplemented with a 3D physical model of the assembly. Card rotation and cube comparison tests were administered to measure spatial cognition. The results support the research hypothesis that both the information format, demographics, and spatial cognition significantly influenced performance. Individual spatial cognition/ work experience significantly influenced the worker's performance, but the format of information can neutralize the effect. When only 2D isometric was provided, participants with relatively low spatial cognition/ or less work experience performed significantly worse than participants with relatively higher spatial cognition or more work experience. However when the 2D isometric drawings were supplemented with 3D information, participants with lower spatial cognition/ or less work experience were able to complete the model assembly as efficiently and effectively as participants with higher spatial cognition/ or more work experience.

3.2 Introduction

3D visualization and data integration have made considerable progress when the design of engineering systems is concerned. However in spite of the fact that 3D CAD and building information models (BIM) have become predominant in design, providing these models to the crafts at the construction workforce is still generally uncommon (Goodrum and Miller 2015). On the other hand, paper-based plans and files are continuously the fundamental formats applied to the engineering information deliverables (Bowden et al., 2006). In this context, a two-dimensional plan set is the primary format of engineering deliverables at the construction workforce.

3.2.1 Influence of Engineering Information Deliverables in the Construction Industry

The utilization of engineering information deliverables is an indispensable part of the production processes among the construction crews. Additionally, the availability and accuracy of engineering information play an important role on construction craft performance. Nevertheless, the two-dimensional drawings that have been used for many years are still problematic to use at the construction workforce. As such, Liberda et al. (2003) asked industry experts to rank 51 variables that influence construction productivity in three classifications, which included labor, management, and the external environment. In the survey, it was observed that lack of essential information required to perform construction was ranked eighth among the 51 factors that were generally experienced by construction experts as obstructions to productivity.

In view of the deductions from the craft workers, the significance of engineering information was observed to be more critical in a study by Naoum (2016), who did a survey with 36 construction firms in order to identify 46 factors affecting construction labor productivity. The delay caused by design error and change orders were ranked second while communication systems were ranked third. Additionally, the lack of integration of the management information systems

for the projects was ranked ninth overall. The same pattern was observed in another similar survey by Dai et al. (2009a) with approximately 2,000 craft workers as participants; 40 percent of the study participants worked in the piping and electrical trades. The survey results show that three among the ten most important issues in the Dai's study revolved around the availability and accuracy of engineering drawings. In addition, the absence of well engineering information influences craft productivity. O'Connor (1985) reported that the lack of well-conveyed information to crafts results in productivity decline.

The previous findings deduced the importance of engineering information deliverables on crafts performance. Adjustments in the acts of providing construction crafts the engineering drawings they need are indispensable to enhance crafts performance. Moreover, understanding how individual craft workers access, view and interpret the information they need to perform their tasks is a basic gap in the current body of knowledge about engineering information deliverables that must be taken into consideration in further research.

3.3 Spatial Cognition

Spatial cognition can be defined as the ability to retain, manipulate and generate precise visual images (Lohman, 1979). Spatial thinking requires the ability to decipher, remember, change, and match spatial stimuli. Lohman (1997) highlights three key spatial factors that determine differences in individual spatial abilities. The first is spatial relations, which is the ability to tackle a problem by use of rotated objects. The second one is spatial orientation, which is the ability to imagine one's orientation in space. The last one is visualization.

Different researchers have been studying spatial cognition for a long time, such as neuroscientists who study relationships among the brain and behavior (Stiles et al., 1988). In psychology, Vecchi and Bottini (2006) studied the relationship between perception and imagery

in order to understand how brain behavior and cognition interrelate. This paper will focus not on the neurologic aspect but on the behavioral aspect and the effect of spatial cognition on individual craft productivity.

3.3.1 Individual Differences in Spatial Cognition

Spatial cognition differs widely among people. When spatial information is received, different people will internalize the information at different rates and efficiencies. These disparities in ability and performance are associated with gender, age, and memory capacity among other things (Baldwin 2009). Realistically, each person has cognitive ability, which is the ability to understand and handle information. Most often, there is a correlation between cognitive ability levels and the ability to interpret display information. In order for a task to be done successfully, the information that is relayed must be properly understood (Ekstrom et al., 1976).

In the construction industry, analysis of a construction superintendent's work tasks showed that information sources must be transportable to the construction site, should be visually editable to show job progress, and should be made available to workers on the project (O'Brien et al., 2011). Craft workers make use of their spatial ability to interpret engineering information, mainly spatial orientation, which is defined as the ability to understand spatial patterns or maintain orientation with regard to objects in space (Ekstrom et al., 1976). However, not all craft workers have the same ability to comprehend the engineering information provided to them. A display that improves performance of one group may not have the same effect on another. Displays should support the information needs of the majority of any population. The ideal outcome is when a display assists a person who is low performing to match the performance of those who perform better (Quarles et al., 2008). Taking into account the difference in levels of cognitive abilities among workers, the information provided should be written so that all the workers can comprehend

it (O'Brien et al., 2011). In short, engineering information deliverables provided to craft workers must be in a formats, such as contextual information, that require the lowest cognitive demand.

3.3.2 Spatial Cognition Tests

The processes of spatial cognition are described as encoding, remembering, transforming, and matching information (Lohman, 1979). Hegarty et al. (2002 & 2006) argue that the spatial abilities measured by traditional measurement instruments, such as mental rotation tasks, do not completely overlap with the abilities needed for goal-directed movements in complex environments (object-level versus environment-level processing). Object-level processing tests seem to be related to the mental changes needed when using visual spatial displays (e.g., engineering plans) to guide task performance in the construction of complex systems. Engineering information formats are complex, and workers need to make use of spatial cognition to interpret information and manipulate patterns and shapes in their mind to create an image. For example, filing through a stack of 2D isometric drawings in order to visualize the whole 3D pipe module requires a considerable amount of spatial cognition.

To determine spatial cognition, the Educational Testing Service (ETS) came up with two tests for assessing the ability to perceive spatial patterns or maintain orientation with regard to objects in space (Ekstrom et al., 1976). These tests are the card rotation test and the cube comparison test. The card rotation test determines the ability to mentally manipulate objects in two dimensions (Figure 3.1). Each question in the test presents a 2D shape and eight similar items. Participants must assert if each object has been rotated (same) or if it has been flipped and rotated (different). The cube comparison test is similar but tests 3D spatial cognitive abilities (Figure 3.2). Each question presents two cubes with a letter marked on each face. The letters do not recur on a single cube. If the first cube can be turned to match the second cube, then the participant marks them as

the same. If the first cube cannot be turned to match the second cube due to incorrect relative positions of the letters, the participant marks them as different.

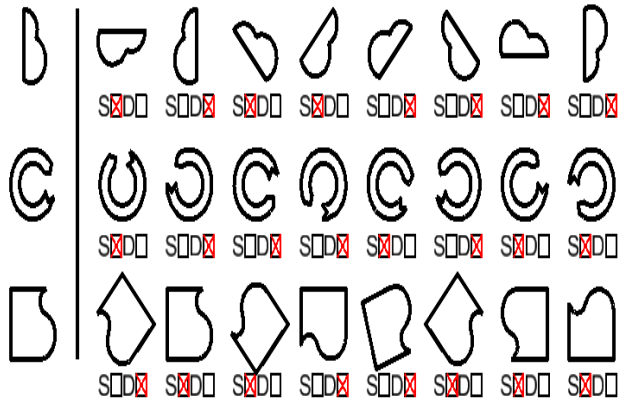

Figure 3.1. Card Rotation Test (Abbreviated)

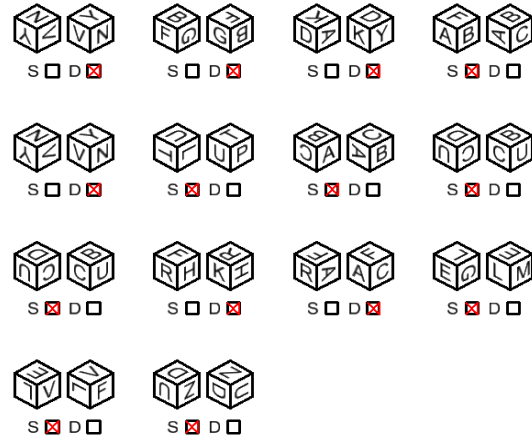

Figure 3.2. Cube Comparison Test (Abbreviated)

3.4 Influence of Engineering Format and Spatial Cognition in Construction Industry

The influence of the spatial cognition and the engineering information has been investigated in the construction industry. Sweany et al., (2016) applied a different sampling plan and identified a statistically significant relationship between information format and performance. In the study, three structural assemblies in the form of a 2D plan set, a 3D CAD model on a digital device, and a 3D physical print were given to construction field supervisors. In each structural assembly, different formats of information were used to control the effects of a learning curve. Task performance was measured through time to complete the assembly, number of installation errors, direct work rate, and indirect work rate. The results show that, when participants used the 2D plan set, they performed worst as compared to using either the 3D CAD model or the 3D physical print. Sweany et al., (2016) additionally found that the relationship between improved performance and the 3D information format was supported when contrasts in spatial cognition were controlled.

Goodrum et al. (2016) examined pipefitters in the U.S and Canada to investigate how spatial cognition impacted their performance on scale model assembly tasks. The participants were given one of three engineering information formats, 2D isometric drawings, 2D isometric drawings improved with a 3D image of the assembly, and 2D isometric drawings improved with a 3D physical print model. The experimental formats were chosen after focusing on six focus groups in Ontario, Louisiana, Texas and Utah. The results indicated that those who used the 2D isometric drawings with the 3D physical model exhibited good performance in three of the four performance metrics—number of errors, direct work, and indirect work. However, those who used the 2D isometric drawings improved with a 3D image of the assembly were the fastest in completing the assembly. Additionally, Goodrum et al. (2016) measured participants' spatial cognition using the card rotation and cube comparison tests. The results indicated that when 2D information was given, participants with low scores in spatial cognition tests performed significantly worse compared to participants with high spatial cognition scores. When the 2D isometric drawings were improved with 3D information, participants with lower spatial cognition completed the model assembly as productively and effectively as participants with higher spatial cognition. The 3D physical model was excluded in the study because of sample size limitations.

This paper's design closely builds on the studies of Sweany et al., (2016) and Goodrum et al. (2016). Some of the limitations of their studies have led to the current need for additional research. The weakness of those studies was that model designs were moderately straightforward. This was necessary because time restrictions for conducting the experiments meant that tests were limited to 30 minutes. Additionally, time was limited because the experiments were conducted during normal work hours, when each participant was being paid by their employer. Since the simplicity of the designs limited the potential for confusion, rework, and mistakes, this led to reduced

variance in the performance metrics. However, in this study, participants were paid for one hour of their time with a specific end goal of allowing us to use more complex designs. We used three designs with various complexities (simple, medium, and complex designs) to analyze whether greater returns in performance are realized from increased complexity. Despite the fact that essential and statistical differences based on types of engineering information were observed, larger sample sizes with more complex designs are justified to more thoroughly examine contributory components, such as age, work experience, training, and other demographic qualities. This paper focuses on the influence of engineering information format, demographic, and spatial cognition on worker performance. The research analysis is guided by a number of hypotheses, including:

- H1: Craft-Workers' spatial cognition influence differently in task performance when using different formats of engineering information.
- H2: Demographics (specifically age and work experience) influence differently in task performance when using different formats of engineering information.
- H3: Workers with high and low spatial cognition abilities/or work experience perform differently when using 2D information, while they perform similarly when using 2D information plus 3D information.

3.5 Related Works from other Domains

The relationship between human spatial cognition and task performance has been determined by previous studies in other fields. The majority of prior studies concerning spatial cognition and task performance have concentrated on various aspects, such as: 1) determining how to supplement human cognitive abilities with developed information interfaces under complex systems such as military aircraft controls (Feuerstack et al., 2015), 2) acknowledging gender differences in spatial

cognitive abilities (Sharps et al., 1994), 3) understanding environmental and physical factors that impact spatial ability (Taylor et al., 2014), and 4) wayfinding and navigation (Baldwin, 2009).

Within this wide scope of research, there have been other studies that associated with this paper, which investigates how user interfaces can be used to supplement human differences in spatial cognition when performing physical tasks. In a workspace where visually complex information is involved, acknowledging individual spatial cognition is just as vital as understanding the method in which information is provided. Various platforms of information delivery may enhance, reduce, or have no effect on user performance. In addition, visualization methods can effectively increase the performance of individuals with low spatial ability. Stanney and Salvendy (1995) used two different user computer interfaces made to ease information access for people with low spatial ability. One of the interfaces made use of a 2D visual hierarchy (i.e., matrix), while the other one made use of a linear structure (i.e., a list). They proved that the 2D visual hierarchy minimized the differences between the people of high and low spatial abilities in understanding requested information.

Other studies have examined how human cognitive performance is greatly affected by new technology. Neumann and Majoros (1998) examined how augmented reality interacts with human cognitive abilities in regard to aircraft maintenance. The research discovered that when the paper-based information with augmented reality images are provided, aircraft mechanics were able to finish simulated tasks quicker and more effectively compared to when only paper-based information is used. Previous findings cleared the way to address challenges that the construction industry faces in reducing the spatial cognitive demand of craft workers by providing new formats of engineering deliverables.

3.6 Methodology

The study relied on empirical data collection methods and quantitative analysis to examine how the use of different engineering information formats, worker spatial cognition, and demographics influence the performance in task execution. The following sections go into more details regarding the study's research methods.

3.6.1 Task Design

The research involved developing model of pipe works with different information formats. The development of the task design in this research built on a study by Goodrum et al. (2016). A piping design (Figure 3.3) with three engineering information formats were developed which include:

- A 10-sheet set of Traditional, 2D isometric drawings (Figure 3.4).
- A 10-sheet set of 2D isometric drawings with 3D images of the assembly (Figure 3.5).
- A 10-sheet set of 2D isometric drawings with a 3D physical print model (Figure 3.6).

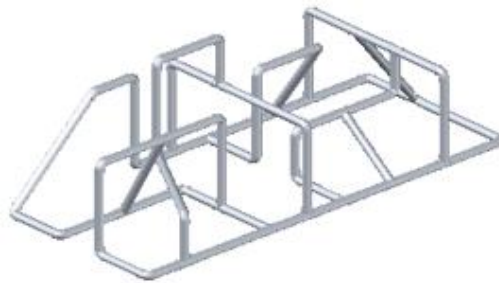

Figure 3.3. Piping Model

Although this study is based on the work of Goodrum et al. (2016), the experimental design presented herein differs in three important ways. First, the experimental design in Goodrum et al (2016) study was relatively simple. The simple designs limited the potential for confusion, rework, and mistakes and reduced the variance of the performance metrics. In this research, the experiment involved a complex design that is similar to what is expected of them on a typical workday.

Second, Goodrum et al (2016) experiment was limited to 30 minutes to minimize the impact of the experiments on construction operations. Time limitation was primarily due to participants being paid by their employer during the experiment. In this research, participants were paid by the study for one hour of their time in order to allow more time to assemble a complex design. Third, previous research did identify differences due to spatial cognition, but it did not examine how individuals with different spatial cognition interface differently with the information and the assembly when it comes to a complex task.

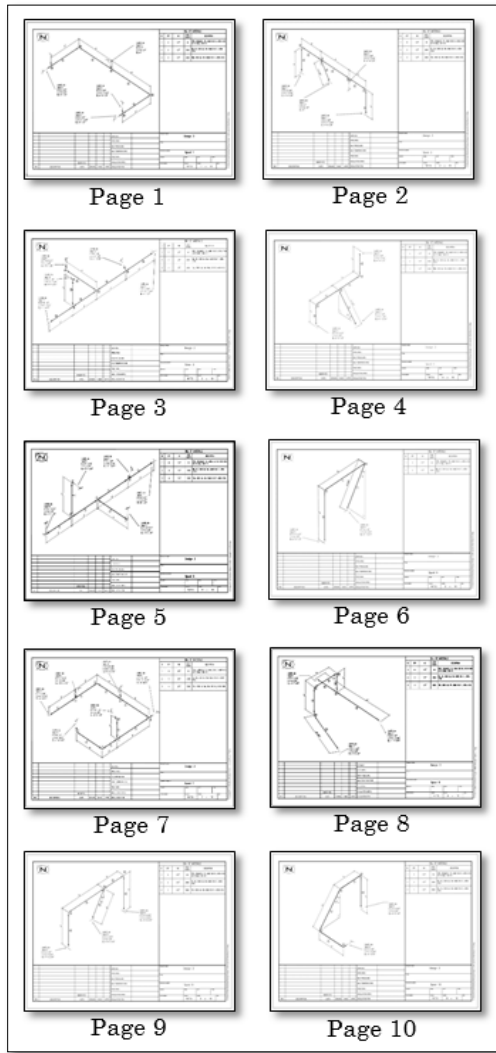

Figure 3.4. 2D Isometric Drawings.

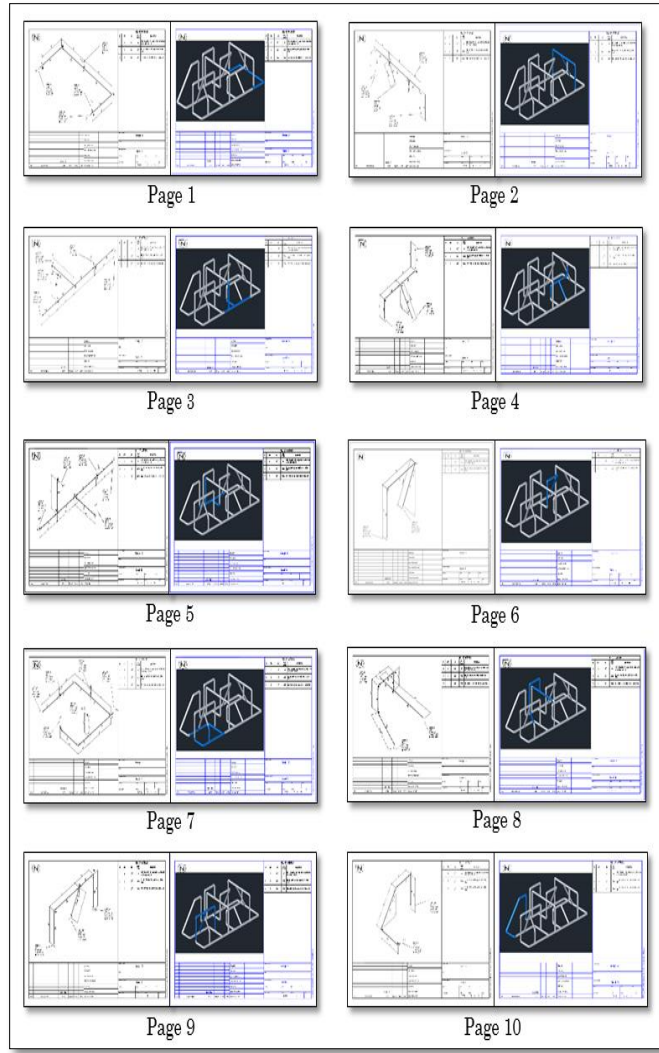

Figure 3.5. 2D Isometric Drawings plus 3D Images.

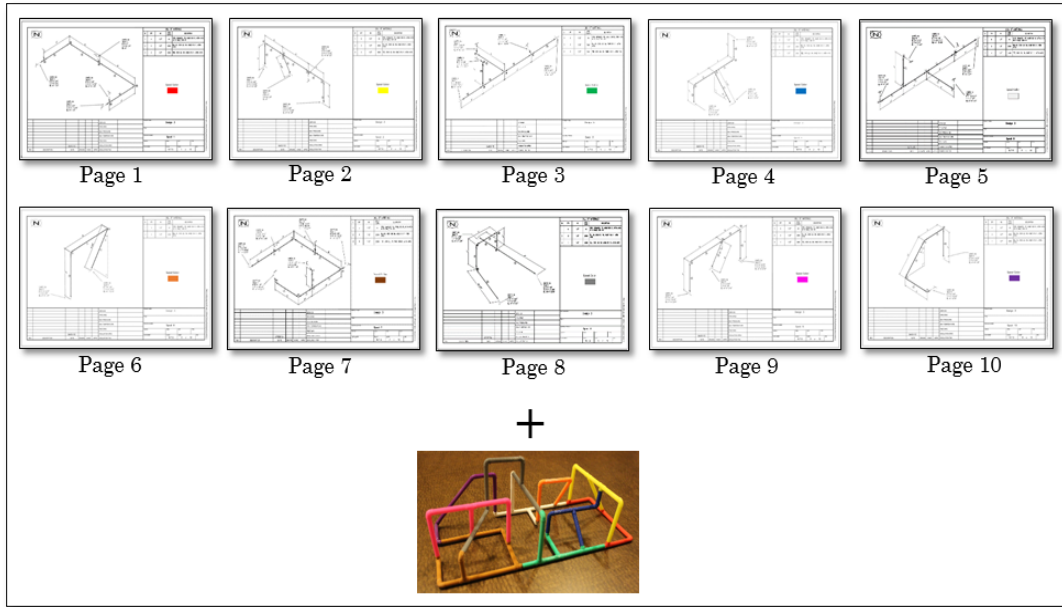

Figure 3.6. 2D Isometric Drawings plus a 3D Physical Model of the Assembly.

3.6.2 Participants

All of the field trial participants were construction workers from the MEP trades. Limiting the participants to the MEP trades is intentional for three reasons. First, isometric drawings are the primary information format provided to the MEP trades. Second, isometrics are one of the most complex information formats provided to all construction-related trades, since the material involves engineered components that must be assembled in a specific order. Third, the MEP trades constitute the largest percentage of direct craft labor and are responsible for a high percentage of material costs on most commercial and industrial projects. As such, the potential for improvement and the impact on industry practice is significant. The study utilized a total of 60 MEP workers from industrial jobsites in the U.S, with most of the participants being member of local pipefitter union chapters in the Colorado Front Range. The participants ranged in age from 18 to 64. Their years of industry experience ranged from 0 to 40 years.

3.6.3 Demographics Questionnaire

All participants completed a short one-page questionnaire to identify their age, work experience, education, and training history. This allowed researchers to test the hypothesis that demographics influence craft workers' ability to effectively use engineering deliverables in their task performance.

3.6.4 Spatial Cognition Tests

The card rotation and cube comparison tests were administered to each participant. These spatial cognition tests allow to examine the influence of spatial ability on workers performance. The card rotation test measures the ability to recognize 2D shapes that have been manipulated, and the cube comparison test is similar but uses 3D cubes that have been manipulated (Ekstron et al. 1976).

3.6.5 Experiment Method

All field trials were conducted in an office setting on jobsites or a training centers. Each trial involved a single participant from an MEP trade with a total of 60 MEP workers, and each participant used one of the three information formats to guide the assembly of a 1:12 scale model of a piping module (Fig. 3.7). Specifically, 20 workers were given 2D isometric drawings, 20 workers were given 2D isometric drawings supplemented with 3D images of the assembly, and 20 workers were given 2D isometric drawings supplemented with a 3D physical model of the assembly. The tasks included reading the drawings, measuring pipe lengths, joining pipe members to create spools, and assembling the spools to complete the model (a spool is an isometric sheet that contains an assembly drawing of pipes and components; a series of spools comprise an entire assembly design.). The pipe was 12.5 mm (½ in.) diameter polyvinyl chloride (PVC). No welding or pipe bending was required. All field trials were video recorded for analysis purpose.

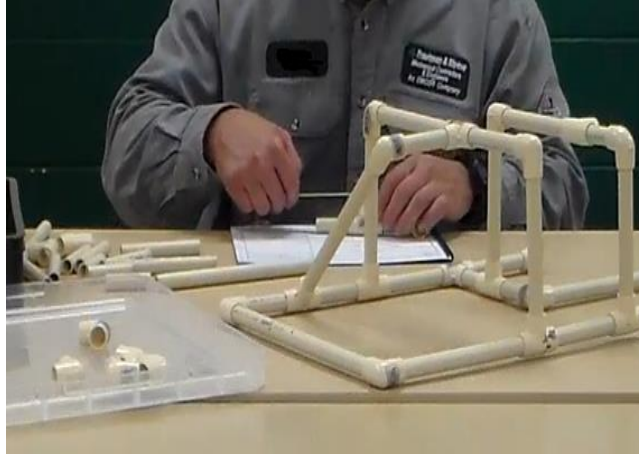

Figure 3.7. Field Trial Experiment

3.6.6 *Experiment Metrics*

To evaluate performance in each experiment, participants were observed at 30-second intervals. Based on the video, each 30-second interval was assigned to one of three categories—direct work, indirect work, and rework.

- *Direct Work*: the physical act of installing pieces, or measuring pieces in order to assemble the model (i.e., handling the PVC pipe, measuring, and joining the pieces).
- *Indirect Work*: the act of reading plans, visualizing how the model is to be assembled, or any other act that is not Direct Work or Rework (e.g., mentally conceptualizing the model).
- *Rework*: the act of removing any piece that has already been assembled, or reinstalling a piece.

The sum of the categories results in the total time that each participant took to assemble the model (*Time to Completion*). In addition, the *number of errors* were counted at the end of each experiment.

3.7 Field Trial Results

3.7.1 Effects of Spatial Cognition and Information Format on Craft Performance

The card rotation and cube comparison tests were administered to explore the relationships between spatial cognition and performance, higher scores indicate higher spatial cognition. The total score in the card rotation test is 40 and in the cube comparison test is 14. To establish comparison groups, the scores on the cube comparison test were scaled to be of equal weight to the scores on the card rotation test. After both scores were scaled to be out of 40 points, they were added together to create a composite spatial cognition score. Participants were then divided into low or high spatial cognition abilities groups based on their composite spatial cognition score when compared to the average of the entire population who participated in the field trials, participants who scored below the average of the composite spatial cognition scores were placed in the low composite spatial cognition group, while those who scored at or above the average were placed in the high composite spatial cognition group.

The results from the composite spatial cognition were used to control for any differences among the individuals' spatial cognition and performance when using different engineering formats. An ANOVA analysis was performed to statistically validate the observed influence that the information type had on each performance metric (i.e., time to completion, direct work, indirect work, rework, and error occurrence). The significance of each performance measure is described by F and the p-values. The F-value is the variance of the group mean. The p-value indicates the significance level of the mean score, or to what degree of confidence that statistic holds, where p-values greater than 0.10 yield confidence of 90% and values less than 0.05 yield confidence of 95% or greater.

3.7.1.1 Effects of Information Format, Controlling for Composite Spatial Cognition Scores

Table 3.1 shows the influence of the composite spatial cognition scores on the performance metrics. Participants in the low spatial cognition group who used the 2D isometric format plus 3D image or physical model performed better than those who used the conventional 2D isometric drawings in all of the performance metrics (i.e., time to completion, direct work rates, indirect work rates, re-work rates, and number of errors), with very strong statistically significant differences.

Participants in the high spatial cognition group who used the 2D isometric format plus a 3D image or physical model also performed better than those who used the conventional 2D isometric drawings in direct work rates and indirect work rates, with very strong statistically significant differences. They also performed better in time to completion and number of errors, but the differences were less statistically significant. In addition, there were no statistically significant differences in re-work rates when the high spatial cognition group used different engineering information formats. These findings suggest that providing additional 3D information allowed both high and low spatial cognition participants to perform better than those who used just 2D information. There were more positive effects for the low spatial cognition group, in whom the 3D information offset the effects of lower spatial cognition.

Table 3.1. Performance Metrics by Information Format Controlling for Composite Spatial Cognition Results

Performance	Info. Format	High Composite Spatial Cognition Score				Low Composite Spatial Cognition Score			
		N	Mean	F	p	N	Mean	F	p
Total Time (minute:sec)	2D Isometric	11	0:33:39	3.00	0.07	8	0:46:07	13.87	0.00
	2D Isometric + 3D Image	10	0:26:16			10	0:27:21		
	2D Isometric + 3D Physical	10	0:25:25			10	0:29:48		
Direct Work %	2D Isometric	11	55.80	7.87	0.00	9	39.05	45.08	0.00
	2D Isometric + 3D Image	10	72.23			10	67.97		
	2D Isometric + 3D Physical	10	65.73			10	65.07		
Indirect Work %	2D Isometric	11	38.57	6.90	0.00	9	48.12	28.53	0.00
	2D Isometric + 3D Image	10	24.57			10	27.72		
	2D Isometric + 3D Physical	10	30.16			10	30.68		
Re-work %	2D Isometric	11	5.63	1.70	0.20	9	12.83	26.45	0.00
	2D Isometric + 3D Image	10	3.20			10	4.32		
	2D Isometric + 3D Physical	10	4.11			10	4.25		
# Errors	2D Isometric	11	0.64	2.80	0.08	9	1.89	9.31	0.00
	2D Isometric + 3D Image	10	0.30			10	0.30		
	2D Isometric + 3D Physical	10	0.00			10	0.50		

3.7.1.2 Effects of Composite Spatial Cognition Scores, Controlling for Information Format

The results of the field trials comparing the performance of high and low spatial cognition participants who were given the same engineering information are shown in Table 3.2. When the participants used the conventional 2D isometric drawings to complete the assembly, participants with higher spatial cognition performed better than participants with lower spatial cognition on all performance metrics, with strong statistically significant differences.

In contrast, the results were dramatically different when participants used the 2D isometric drawings plus a 3D image or 3D physical model. Both high and low spatial cognition participants performed almost equally in all performance metrics, and there were no statistically significant differences between groups, except in the number of errors when they used 2D isometric drawings plus a 3D physical model. The results indicate that 2D isometric drawings plus a 3D image or 3D physical model allowed participants with lower spatial cognition to perform as efficiently and

effectively as those with higher spatial cognition. Figure 3.8 shows the average measures of total time by information type and the composite spatial cognition results.

Table 3.2. Performance Metrics by Composite Spatial Cognition Results Controlling for Information Format.

Performance	L/H Spatial Cognition Score	2D Isometric				2D Isometric + 3D Image				2D Isometric + 3D Physical			
		N	Mean	F	p	N	Mean	F	p	N	Mean	F	p
Total Time (minute:sec)	Low Spatial Cognition Score	8	0:46:07	7.92	0.01	10	0:27:21	0.09	0.77	10	0:29:48	1.80	0.20
	High Spatial Cognition Score	11	0:33:39			10	0:26:16			10	0:25:25		
Direct Work %	Low Spatial Cognition Score	9	39.05	13.59	0.00	10	67.97	1.77	0.20	10	65.07	0.03	0.86
	High Spatial Cognition Score	11	55.80			10	72.23			10	65.73		
Indirect Work %	Low Spatial Cognition Score	9	48.12	6.55	0.02	10	27.72	1.08	0.31	10	30.68	0.02	0.88
	High Spatial Cognition Score	11	38.57			10	24.57			10	30.16		
Re-work %	Low Spatial Cognition Score	9	12.83	15.09	0.00	10	4.32	2.76	0.11	10	4.25	0.01	0.92
	High Spatial Cognition Score	11	5.63			10	3.20			10	4.11		
# Errors	Low Spatial Cognition Score	9	1.89	6.52	0.02	10	0.30	0.00	1.00	10	0.50	5.00	0.04
	High Spatial Cognition Score	11	0.64			10	0.30			10	0.00		

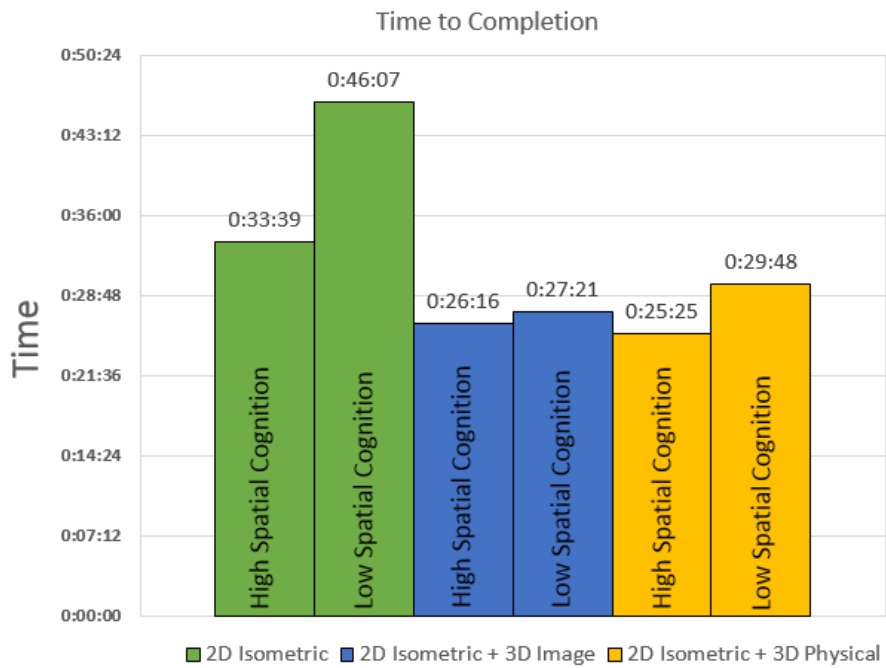

Figure 3.8. Total Time by Information Format and Spatial Cognition Results.

3.7.2 Effects of Age, Work Experience and Information Format.

The research also examined the influence of the individuals' age and work experience on their ability to effectively use engineering formats in their task performance. The average results of age and work experience were used to establish comparison groups. The participants who were below the average age were placed in the low age group, while those who were at or above the average were placed in the high age group. The same process with corresponding group labels was used to form comparison groups for the work experience analysis (e.g., low work experience).

3.7.2.1 Effects of Information Format, Controlling for Age

Table 3.3 shows the influence of age on the performance metrics. Participants in the low age group who used the 2D isometric format plus a 3D image or physical model performed better than those who used the conventional 2D isometric drawings on all of the performance metrics (i.e., time to completion, direct work rates, indirect work rates, re-work rates, and number of errors) with very strong statistically significant differences.

Participants in the high age group who used the 2D isometric format plus a 3D image or physical model also performed better in terms of direct work rates and indirect work rates than their counterparts who used the 2D isometric drawings, with very strong statistically significant differences. They also performed better than their counterparts in terms of time to completion and re-work rates, but with less statistically significant differences. In addition, there were no statistically significant differences in the number of errors when the high age group used different engineering information formats. These findings suggest that providing additional 3D information allowed both high and low age groups to perform better than those who used just 2D information, and the effects were more positive for the low age group, in which the 3D information offset the effects of lower age.

Table 3.3. Performance Metrics by Information Type Controlling for Age.

Performance	Info. Format	High Age				Low Age			
		N	Mean	F	p	N	Mean	F	p
Total Time (minute:sec)	2D Isometric	9	0:36:42	2.51	0.10	10	0:40:53	9.03	0.00
	2D Isometric + 3D Image	9	0:28:49			11	0:25:10		
	2D Isometric + 3D Physical	10	0:29:01			10	0:26:11		
Direct Work %	2D Isometric	9	51.90	9.91	0.00	11	45.29	18.97	0.00
	2D Isometric + 3D Image	9	71.95			11	68.58		
	2D Isometric + 3D Physical	10	64.05			10	66.75		
Indirect Work %	2D Isometric	9	41.25	9.65	0.00	11	44.19	13.35	0.00
	2D Isometric + 3D Image	9	24.76			11	27.27		
	2D Isometric + 3D Physical	10	30.87			10	29.97		
Re-work %	2D Isometric	9	6.85	2.54	0.10	11	10.52	12.85	0.00
	2D Isometric + 3D Image	9	3.29			11	4.14		
	2D Isometric + 3D Physical	10	5.08			10	3.28		
# Errors	2D Isometric	9	0.67	1.97	0.16	11	1.64	7.03	0.00
	2D Isometric + 3D Image	9	0.22			11	0.36		
	2D Isometric + 3D Physical	10	0.10			10	0.40		

3.7.2.2 Effects of Age, Controlling for Information Format

The results comparing the performance of younger and older participants who were given the same engineering information format are shown in Table 3.4. When the same information format was provided, both younger and older participants performed similarly in all of the performance metrics, with no statistically significant differences. Except in the 2D isometric format, older participants had fewer errors than younger participants.

These results indicate that younger and older participants perform similarly when using any type of engineering information. Figure 3.9 shows the average measures of total time by information type and age.

Table 3.4. Performance Metrics by Age Controlling for Information Format.

Performance	L/H Age	2D Isometric				2D Isometric + 3D Image				2D Isometric + 3D Physical			
		N	Mean	F	p	N	Mean	F	p	N	Mean	F	p
Total Time (minute:sec)	Low Age	10	0:40:53	0.65	0.43	11	0:25:10	1.10	0.31	10	0:26:11	0.71	0.41
	High Age	9	0:36:42			9	0:28:49			10	0:29:01		
Direct Work %	Low Age	11	45.29	1.29	0.27	11	68.58	1.06	0.32	10	66.75	0.58	0.46
	High Age	9	51.90			9	71.95			10	64.05		
Indirect Work %	Low Age	11	44.19	0.47	0.50	11	27.27	0.67	0.42	10	29.97	0.07	0.80
	High Age	9	41.25			9	24.76			10	30.87		
Re-work %	Low Age	11	10.52	2.41	0.14	11	4.14	1.51	0.24	10	3.28	2.40	0.14
	High Age	9	6.85			9	3.29			10	5.08		
# Errors	Low Age	11	1.64	3.41	0.08	11	0.36	0.43	0.52	10	0.40	1.53	0.23
	High Age	9	0.67			9	0.22			10	0.10		

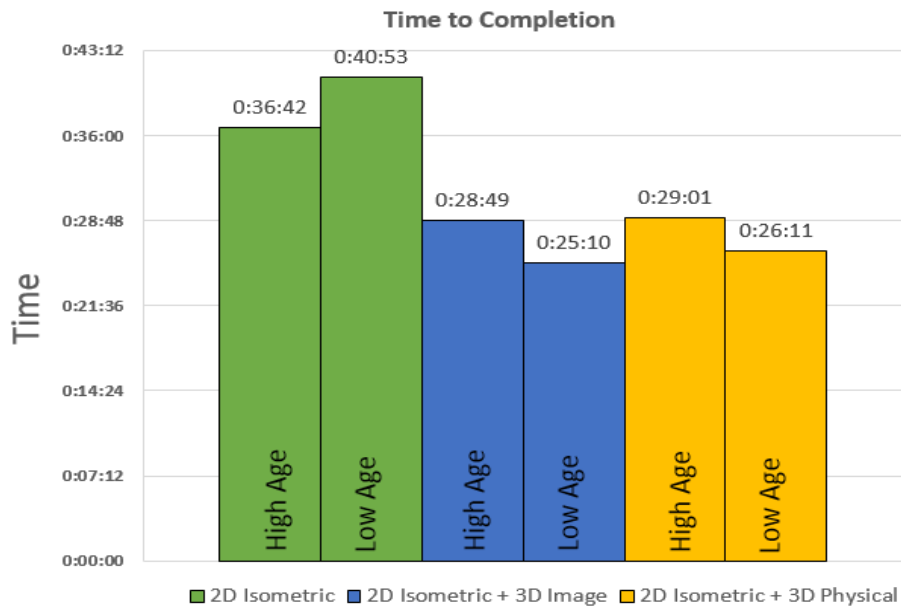

Figure 3.9. Total Time by Information Format and Age.

3.7.2.3 Effects of Information Format, Controlling for Work Experience

Table 3.5 shows the influence of work experience on the performance metrics. Participants with less work experience who used the 2D isometric format plus a 3D image or physical model performed better than their counterparts who used the 2D isometric drawings on all of the performance metrics (i.e., time to completion, direct work rates, indirect work rates, re-work rates, and number of errors), with very strong statistically significant differences.

Table 3.5. Performance Metrics by Information Type Controlling for Work Experience.

Performance	Info. Format	High Work Experience				Low Work Experience			
		N	Mean	F	p	N	Mean	F	p
Total Time (minute:sec)	2D Isometric	9	0:34:41	2.75	0.08	10	0:42:41	9.10	0.00
	2D Isometric + 3D Image	7	0:28:44			13	0:25:46		
	2D Isometric + 3D Physical	10	0:27:31			10	0:27:41		
Direct Work %	2D Isometric	9	53.59	9.64	0.00	11	43.91	20.63	0.00
	2D Isometric + 3D Image	7	72.47			13	68.82		
	2D Isometric + 3D Physical	10	66.52			10	64.28		
Indirect Work %	2D Isometric	9	39.88	8.75	0.00	11	45.31	15.35	0.00
	2D Isometric + 3D Image	7	24.54			13	27.01		
	2D Isometric + 3D Physical	10	29.35			10	31.50		
Re-work %	2D Isometric	9	6.53	2.42	0.11	11	10.78	12.60	0.00
	2D Isometric + 3D Image	7	2.99			13	4.17		
	2D Isometric + 3D Physical	10	4.14			10	4.22		
# Errors	2D Isometric	9	0.44	0.76	0.48	11	1.82	12.02	0.00
	2D Isometric + 3D Image	7	0.29			13	0.31		
	2D Isometric + 3D Physical	10	0.10			10	0.40		

However, when provided with the 2D isometric format plus 3D image or physical model, participants with more work experience also performed better than their counterparts who used the 2D isometric drawings in terms of time to completion, direct work rates, and indirect work rates, with statistically significant differences. They also performed better on time to completion, but the differences were less statistically significant. In addition, there were no statistically significant

differences in re-work rates and number of errors when participants with more work experience used any type of engineering information format. These findings suggest that providing additional 3D information allowed both high and low work experience participants to perform better than their counterparts who used just a 2D information. The effects were more positive for participants with less work experience, in whom the 3D information offset the effects of low work experience.

3.7.2.4 Effects of Work Experience, Controlling for Information Format

The results of the field trials comparing the performance of high and low work experience participants who were given the same engineering information are shown in Table 3.6. When the participants used the conventional 2D isometric drawings to complete the assembly, participants with more work experience performed better than participants with less work experience in terms of direct work rates, re-work rates, and number of errors, with strong statistically significant differences. However, there were no statistically significant differences in time to completion or indirect work rates. More experienced workers were more likely to have experience working with engineering drawing sets. Their familiarity with these sets would have allowed them to find the information quickly and use the saved time on direct work.

In contrast, the results were dramatically different when participants used the 2D isometric drawings plus a 3D image or 3D physical model. Both high and low work experience participants performed almost equally in all performance metrics with no statistically significant differences. These results suggest that 2D isometric drawings plus a 3D image or 3D physical model allowed the less experienced workers to perform as efficiently and effectively as the more experienced workers. Figure 3.10 shows the average measures of total time by information type and work experience.

Table 3.6. Performance Metrics by Work Experience Controlling for Information Format.

Performance	L/H Work Experience	2D Isometric				2D Isometric + 3D Image				2D Isometric + 3D Physical			
		N	Mean	F	p	N	Mean	F	p	N	Mean	F	p
Total Time (minute:sec)	Low Work Experience	10	0:42:41	2.63	0.12	13	0:25:46	0.65	0.43	10	0:27:41	0.00	0.96
	High Work Experience	9	0:34:41			7	0:28:44			10	0:27:31		
Direct Work %	Low Work Experience	11	43.91	3.03	0.10	13	68.82	1.14	0.30	10	64.28	0.39	0.54
	High Work Experience	9	53.59			7	72.47			10	66.52		
Indirect Work %	Low Work Experience	11	45.31	1.70	0.21	13	27.01	0.59	0.45	10	31.50	0.39	0.54
	High Work Experience	9	39.88			7	24.54			10	29.35		
Re-work %	Low Work Experience	11	10.78	3.40	0.08	13	4.17	2.76	0.11	10	4.22	0.00	0.95
	High Work Experience	9	6.53			7	2.99			10	4.14		
# Errors	Low Work Experience	11	1.82	8.47	0.01	13	0.31	0.01	0.92	10	0.40	1.53	0.23
	High Work Experience	9	0.44			7	0.29			10	0.10		

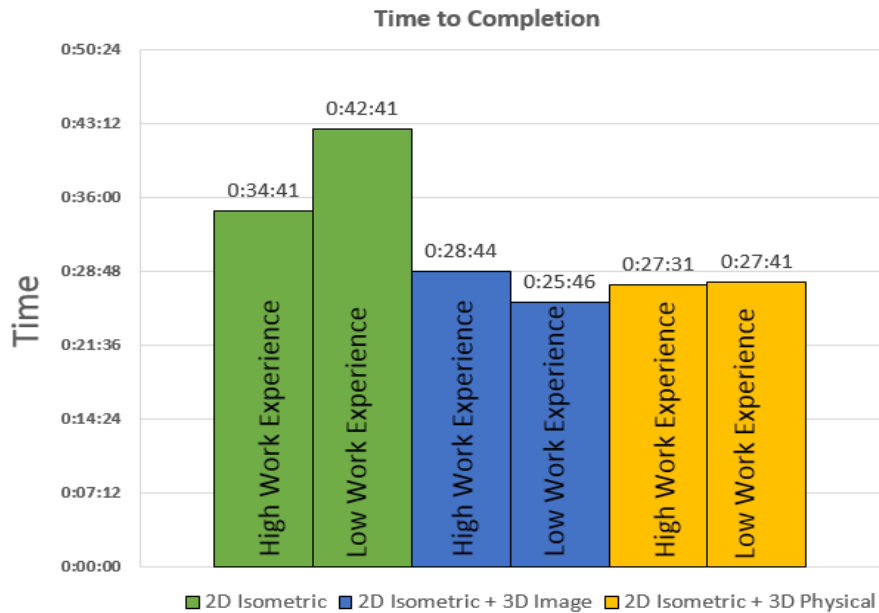

Figure 3.10. Total Time by Information Format and Work Experience.

3.8 Limitations

The study relied on empirical data collection through using a scale model of pipe works with different information formats. The scale of the model assembly task is a limitation of this research.

Pipe used on most industrial projects is often 152.4 mm (6 in.) in diameter or larger, which is

significantly larger than the 12.7 mm (0.5 in.) PVC pipe used in this study. Although fitting pipe requires more tasks (e.g., welding, material and equipment handling, and bolting), this research model focused only on measuring and assembling pipes through reading and understanding engineering drawings, which is the most important task in the industrial pipefitting. Also this research focused on three factors that affect worker productivity; information format, spatial cognition and demographic. However, construction sites are dynamic environments with numerous factors affecting craft workers' performance, such as information, equipment, tools, materials, rework, supervision, congestion, safety, weather, sequencing, individual skills of workers, size of components, specification, work content, design features, and work scope (Thomas and Sakarcan 1994). The authors readily acknowledge that these and other jobsite factors would likely influence results, if the field trials were conducted on a construction worksite versus being conducted in a controlled setting.

3.9 Conclusion

The primary contribution of this paper is the finding that information format, spatial cognition, and demographics play a significant role in construction craft productivity. Building upon research conducted by Dadi et al. (2014), Sweany et al (2016), and Goodrum et al. (2016), field data were used in this study to find the correlations between engineering information formats, spatial cognition abilities, and demographics when workers were performing a complex design. Through the use of more complex designs, the results supported the previous findings from the work of Goodrum et al. (2016) that workers with high spatial cognition and those with low spatial cognition perform differently when using 2D information format, while they perform similarly when using 2D information plus 3D information, but the differences were greater with more complex designs.

Providing 3D information with 2D information allowed low age and/or low work experience groups to perform better than their counterparts who used 2D information, with very strong

statistically significant differences. In these groups, the 3D information offset the effects of lower age and work experience. In addition, when provided with 2D and 3D information, high age and/or high work experience groups performed better than their counterparts who used 2D information, although the differences were less statistically significant in the high work experience group.

Workers with more work experience and those with less work experience performed differently when using the 2D information format, whereas they performed similarly when using 2D information plus 3D information. A list of statistically proven trends is available in Table 3.7.

Table 3.7. Trends Statistically Proven

Number	Hypothesis	Result
1	Craft-Workers' spatial cognition influence differently in task performance when using different formats of engineering information.	Both high and low spatial cognition participants performed the best when using either the 2D isometric format plus 3D image or the 2D isometric format plus 3D physical model and the worst when using the 2D isometric format. With more effects for low spatial cognition participants.
2	When using different formats of engineering information, demographics (specifically age and work experience) influence differently in task performance	Providing 3D information with 2D information allowed both high and low age/or work experience groups to perform better than their counterparts who use 2D information, with more positive effects for low age/ or work experience group.
3	Workers with High and low spatial cognition abilities/or work experience perform differently when using 2D information, while they perform similarly when using 2D information plus 3D information.	When using conventional 2D format of information, workers with lower spatial cognition/or experience perform worse in executing an assigned task, compared to workers with higher spatial cognition/or experience.

While most construction companies may be primarily concerned with worker productivity, the format of engineering information greatly affects their performance. In order to have the capability to significantly improve the performance of craft workers, construction companies need to take into consideration the influence of engineering deliverables and workers' spatial cognitive abilities and demographics. The significance of spatial cognitive ability among craft workers has been seen in its capacity to facilitate the interpretation of visual representations of design ideas and increase problem-solving capacity, particularly in complex projects. Nonetheless, differences in spatial cognitive abilities among craft workers are expected. As a result, it is imperative to consider the integration of spatial cognition so as to alleviate the impacts of individual differences in cognitive abilities. Programs involved in craft training may assist new trainees in getting used to plan reading abilities more efficiently. Upon employing such training programs, trainees with low spatial cognition eventually become as efficient as those with higher spatial cognition.

Socially, individuals depend on information to conduct most critical day-to-day tasks. This research has indicated how execution of physical construction tasks is highly dependent on information formats, spatial cognition, and demographics towards achieving craft efficiency and effectiveness. These results are significant in determining the best information format to pave the way for other non-construction tasks. Furthermore, this research provides construction academia with the rationale that greater accommodation for lower spatial cognition is essential. For the purposes of progress across all worker skilled crafts, it is imperative for management to assist workers with meaningful 3D visual enhancements. Nonetheless, assessment for spatial cognition ought to be performed to comprehend the most appropriate location for implementing 3D visual enhancements.

References

- Baldwin, C. L. (2009). "Individual differences in navigational strategy: Implications for display design. Theory". *Issues Ergon. Sci.*, 10(5), 443–458.
- Bowden, S., Dorr, A., Thorpe, A., Anumba, C. (2006). "Mobile ICT Support for Construction Process Improvement". *Automation in Construction* Vol. 15 (5). 664–676.
- Dadi, G. B., Goodrum, P. M., Taylor, T. R., and Carswell, C. M. (2014a). "Cognitive Workload Demands Using 2D and 3D Spatial Engineering Information Formats." *Journal of Construction Engineering and Management*, 140(5).
- Dadi, G. B., Goodrum, P. M., Taylor, T. R., & Maloney, W. F. (2014b). "Effectiveness of communication of spatial engineering information through 3D CAD and 3D printed models". *Visualization in Engineering*, 2(1), 1-12.
- Dadi, G. B., Taylor, T. R., Goodrum, P. M., & Maloney, W. F. (2014c). "Performance of 3D computers and 3D printed models as a fundamental means for spatial engineering information visualization." *Canadian Journal of Civil Engineering*, 41(10), 869-877.
- Dai, J., Goodrum, P. M., and Maloney, W. F. (2009a). "Construction Craft Worker' Perceptions of the Factors Affecting Their Productivity". *Journal of Construction Engineering and Management*, (135), 217–226.
- Ekstrom, R. B., French, J. W., Harman, H. H., and Dermen, D. (1976). "Manual for kit of factor-referenced cognitive tests", *Educational Testing Service*, Princeton, NJ.
- Emmitt, S. and Gorse, C. (2003). "Construction Communication". *Blackwell Publishing*, Oxford.
- Feuerstack, S., Lüdtke, A., and Osterloh, J. P. (2015). "A tool for easing the cognitive analysis of design prototypes of aircraft cockpit instruments: The human efficiency evaluator." Proc., *European Conf. on Cognitive Ergonomics 2015*, ACM, New York, 22.
- Goodrum, P. M., and Miller, J. M. (2015). "Innovative delivery methods of information to the crafts." *Construction Industry Institute*, Univ. of Texas at Austin, Austin, TX. RT 327.
- Goodrum, P., Miller, J., Sweany, J., and Alruwaythi, O. (2016). "Influence of the Format of Engineering Information and Spatial Cognition on Craft-Worker Performance". *ASCE Journal of Construction Engineering and Management*, Vol. 142, No. 9.
- Gouett, M., Haas, C., Goodrum, P., and Caldas, C. (2011). "Activity analysis for direct-work rate improvement in construction". *ASCE Journal of Construction Engineering and Management*, 37: 1117-1124.

- Hegarty, M., Richardson, A. E., Montello, D. R., Lovelace, K., & Subbiah, I. (2002). "Development of a self-report measure of environmental spatial ability". *Intelligence*, 30, 425–447.
- Liberda, M., Ruwanpura, J., & Jergeas, G. (2003). "Construction Productivity Improvement: A Study of Human, Management and External Issues." ASCE. *Construction Research Congress*. 1–8. 10.1061/40671(2003)5.
- Lohman, D. F. (1979). "Spatial ability: A review and reanalysis of the correlational literature". Rep. No. ADA075972, *U.S. Office of Naval Research*, Arlington, VA.
- Naoum, S. G., (2016), "Factors influencing labor productivity on construction sites: A state of the art literature review and a survey". *International Journal of Productivity and Performance Management*.
- Neumann, U., and Majoros, A. (1998). "Cognitive, performance, and systems issues for augmented reality applications in manufacturing and maintenance". Proc., *Virtual Reality Annual Int. Symp.*, IEEE, Washington, DC, 4–11.
- O'Brien, W. J., Hurley, M. J., Mondragon Solis, F. A., and Nguyen, T. (2011). "Cognitive task analysis of superintendent's work: A case study and critique of supporting information technologies". *J. Inform. Technol. Constr.*, 16(2011), 529–566.
- O'Connor, J. T. (1985). "Impacts of Constructability Improvement." *ASCE Journal of Construction Engineering and Management*, (111) 404–410.
- Quarles, J., Lamptang, S., Fischler, I., Fishwick, P., & Lok, B. (2008). "Tangible user interfaces compensate for low spatial cognition. In 3D User Interfaces", 2008. 3DUI 2008. IEEE *Symposium on* (pp. 11–18).
- Sharps, M., Price, J., and Williams, J. (1994). "Spatial cognition and gender: Instructional and stimulus influences on mental image rotation performance". *Psychol. Women Q.*, 18(3), 413–425.
- Stanney, K. M., and Salvendy, G. (1995). "Information visualization; assisting low spatial individuals with information access tasks through the use of visual mediators." *Ergonomics*, 38(6), 1184–1198.
- Stiles, J., Kritchevsky, M., Bellugi, U. (1988), "Spatial Cognition: Brain Bases and Development." *Psychology Press*.
- Sweany, J., Goodrum, P., Miller, J. (2016). "Analysis of empirical data on the effects of the format of engineering deliverables on craft performance". *Automation in Construction*, Volume 69. (2016) 59-67

Taylor, H., Thomas, A., Artuso, C., and Eastman, C. (2014). "Effects of global and local processing on visuospatial working memory". *Spatial Cognition IX: Int. Conf., Bremen, Springer, Switzerland*, 14–75.

Thomas, R., and Sakarcan, A. S. (1994). "Forecasting labor productivity using factor model". *Journal of Construction Engineering and Management*. 10.1061/ (ASCE) 0733 9364(1994)120:1(228), 228–239.

Vecchi, T., Bottini, G. (2006). "Imagery and Spatial Cognition: Methods, models and cognitive assessment." *John Benjamins Publishing*.

CHAPTER 4: THE IMPACT OF DIFFERENT FORMATS OF ENGINEERING INFORMATION AND SPATIAL COGNITION ON CRAFT WORKER EYE GAZE PATTERNS

4.1 Abstract

The construction productivity of craft-workers is negatively impacted by ineffective communication of the project's design. Traditional delivery of Mechanical, Electrical, and Plumbing (MEP) designs rely on two-dimensional isometric drawings. Advancements in three-dimensional (3D) computer aided design (CAD), augmented reality, virtual reality, and 3D printing have provided new format options for delivering engineering information, however providing them to crafts for use at the construction workface remains relatively rare. The objective of this research is to understand how eye gaze patterns of construction craft workers influences information formats and spatial cognition when building a complex spatial task. A series of field trials with MEP workers was conducted to examine the influence of information format and spatial cognition on their eye gaze patterns in building a scale model task assembly. Participants were provided eye tracking glasses with one of three information formats: two dimensional (2D) isometric drawings; 2D isometric drawings supplemented with a three dimensional (3D) image of the assembly; and 2D isometric drawings supplemented with a 3D physical model of the assembly. Card rotation and cube comparison tests were administered to measure spatial cognition. The results of this paper reveal that the information format and spatial cognition significantly influenced workers' eye gaze pattern; there are different gaze patterns for different information formats and these differences in gaze patterns were associated with differences in spatial cognition abilities. Additionally, the improvement in performance when using different engineering information format is associated to eye gaze patterns.

4.2 Introduction

Engineering information deliverables are the essential outcome of design and play an integral role in the construction process that is utilized by craft to build a project. Engineering information deliverables are the drawings and specifications that are required by craft to execute any task or process in a construction workface. Over several decades ago, 3D visualization and data integration made considerable progress when the design of engineering systems is concerned. However in spite of the fact that 3D CAD and building information models (BIM) have become predominant in design, providing these models to be used by the crafts at the construction workface is still generally uncommon (Goodrum and Miller 2015). On the other hand, paper-based plans and files are continuously the fundamental formats applied to the engineering information deliverables (Bowden et al., 2006). In this context, a two-dimensional plan set is the primary format of engineering deliverables at the construction workface.

The utilization of engineering information deliverables is an indispensable part of the production processes among construction crews. Additionally, the availability and accuracy of engineering information play an important role on construction craft performance. Nevertheless, the two-dimensional drawings that have been used for many years are still problematic to use at the construction workface. As such, Liberda et al. (2003) asked industry experts to rank 51 variables that influence construction productivity in three classifications, which included labor, management, and the external environment. In the survey, the lack of essential information required to perform construction was ranked eighth among the 51 factors that were generally experienced by construction experts as obstructions to productivity.

In view of the deductions from craft workers, the significance of engineering information was observed to be more critical in a study by Naoum (2016) conducted a survey with 36 construction

firms to obtain factors affecting construction labor productivity. The delay caused by design error and change orders ranked second, while communication systems ranked third. Additionally, lack of integration of management information systems also ranked in the top ten. The same pattern was observed in a similar survey by Dai et al. (2009a) with approximately 2,000 craft workers as participants, 40 percent of the study participants worked in the piping and electrical trades. The survey results show that three of the ten most important issues in Dai's study revolved around the availability and accuracy of engineering drawings. Additionally, O'Connor (1985) reported that the lack of well-conveyed information to crafts results in productivity declines.

The previous findings highlight the importance of engineering information deliverables in craft worker performance. Adjustments in the acts of providing construction crafts the engineering drawings they need are indispensable to enhance crafts performance. Moreover, understanding how individual craft workers access, view and interpret the information they need to perform their tasks is a basic gap in the current body of knowledge that must be taken into consideration in further research.

4.3 Previous Construction Research

Previous studies have examined the influence of the format of engineering information, demographics, and spatial cognition on craft-worker performance, (Dadi et al., 2014 a, b, c; Sweany et al., 2016; and Goodrum et al., 2016). Dadi et al. (2014 a, b, c) examined the cognitive load and the performance of 26 participants through utilizing 2D plan drawings, 3D CAD, and a 3D printed model to build scale model assemblies. The results indicate that greater cognitive demand was associated with 2D engineering deliverables and lower cognitive demands were associated with 3D engineering deliverables, but the authors were not able to fully identify a relationship between the format of engineering deliverables and craft performance. Through

application of a different experimental plan with structural ironworkers, Sweany et al., (2016) identified a statistically significant relationship between information format and task performance. When participants used the 2D plan set, they performed worst as compared to using either the 3D CAD model or the 3D physical print. Goodrum et al. (2016) investigated how pipefitters' spatial cognition influenced their performance on a scale model assembly task. They successfully found that when only 2D information was provided, participants with relatively low spatial cognition performed significantly worse than participants with relatively higher spatial cognition. When the 2D isometric (iso) drawings were supplemented with 3D information, participants with lower spatial cognition were able to complete the model assembly as efficiently and effectively as participants with higher spatial cognition.

This research builds on the previous studies by providing a deeper understanding of “how and why” different formats of engineering information and spatial cognition influence craft workers' performance through examination of eye gaze patterns. The authors use eye tracking technology to record and analyze workers' eye movements to better understand how workers make use of the format of engineering deliverables and also how the format of information can control the differences in eye gaze patterns and improve human performance in spatially complex tasks. The research analysis is guided by a number of hypotheses, including:

- H1: There are different eye gaze patterns when using different information formats;
 - H2: The improvement in performance when using different engineering information format is associated to eye gaze patterns;
 - H3: Differences in gaze patterns are associated with differences in spatial cognition;
- and

- H4: Workers with lower spatial cognition tend to fixate more on 3D information compared to workers with a higher spatial cognition.

4.4 Eye Tracking Technology

Eye tracking is a system by which the eye movements of a person are recorded and evaluated. Researchers can identify both where the individual is looking at a given time and the order in which they shift their eyes from one location to another (Hasanzadeh et al., 2016). Investigating the movement of the eye provides useful information about the gaze pattern of the subject, based on where and what the subject is looking at. According to Robert et al. (2013), studies have shown that the records regarding eye movements show the subjects' level of attention, awareness, degree of fatigue, perception and cognitive processes. Because eye movements give insight into reasoning, problem solving, and search strategy, numerous studies have applied objective methodologies in assessing the connection between oculomotor behavior and cognitive processes during diverse visual tasks.

4.5 Eye Tracking Measures

The major measurements applied in the research of eye tracking include fixation and saccades. In addition, there are numerous derived metrics that are based on these fundamental measurements including gaze and scan path measurements, the number of fixation revisits to the same target, pupil size, and blink rate (Poole and Ball, 2005). Fixations are moments when the eyes are relatively stationary, taking in or "encoding" information. Fixation is interpreted differently depending on the given context. In a task of encoding, a higher frequency of fixation in a given area indicates that there is a greater interest in the target. It can also be a sign that the target is complex and more challenging to encode (Poole and Ball, 2005). The fixation duration is associated with the time used to process the fixated object. A longer fixation duration indicates the

fixated object is more engaging or the person is having difficulty extracting information (Just & Carpenter, 1976). A high number of fixations shows less efficient searching ability or high uncertainty when it comes to recognition of the targeted item (Goldberg & Kotval, 1999).

Saccades are quick eye movements occurring between fixations. During saccades, encoding does not take place, therefore it is difficult to know the complexity or the salience of an object in the interface. Nevertheless, regressive saccades can act as a measure of difficulty of processing during the encoding process (Rayner & Pollatsek, 1989). In addition, regressive saccades can be applied as a measure of value recognition, in that there is an inverse connection between the number of regressions and the salience of the object being viewed. Other saccade-derived metrics include the number of saccades, indicating more searching; the amplitude of saccades showing more meaningful cues; and saccades revealing marked changes of direction, indicating a rapid shift in direction (Poole and Ball, 2005).

A scan path illustrates a whole sequence encompassing saccade, fixation and saccade (Goldberg & Kotval, 1999). In the task of searching, an optimal scan path can be viewed as a straight line directed toward the target, with a comparatively short duration of fixation on the target. Poole and Ball (2005) state that, quantitatively, scan paths can be evaluated from derived measures, including the length of a scan path, whereby a long scan path shows less searching efficiency; the duration of the scan path, which shows less effective scanning in the case of a longer-lasting scan path; a transition matrix, indicating the order of searching in relation to the transitions from one area to another; and the fixation ratio, which compares time spent in the process of searching to time spent in fixation.

In regards to blink rate and pupil size, Bruneau et al., (2002) state that the blink rate and the pupil size can be applied to a cognitive workload index. There is an assumption that a lower rate

of blink shows a higher workload and a higher blink rate may show an element of fatigue. In addition, larger pupils may show more cognitive efforts Marshall (2000). Nevertheless, Poole and Ball (2005) mentioned that the pupil size and blink rate can be affected by other factors, such as ambient light levels, and so, are open to contamination. Therefore, the pupil size and the blink rate are less frequently used in eye tracking research.

4.6 How an Eye Tracker Works

The concept of an eye tracker derives from the definition of eye tracking, which simply means the measurement of eye activity. It is important to understand how eye trackers work. According to Goldberg & Wichansky (2003), the majority of the available commercial systems for eye tracking measure the point of regard by the method of corneal-reflection/pupil-center. In this method, the eye tracker utilizes an infrared light source to illuminate the eye and create highly visible reflections and a high-resolution camera to capture an image of the eye showing these reflections (Poole and Ball, 2005).

4.7 Eye Tracking Application Areas

Studies have indicated that through the recording of eye movement, it is possible to understand the cognitive and behavioral processing of users and interpret their response to diverse image stimuli (Pradhananga et al., 2016). Eye tracking can be used to evaluate the mental state of the user by using visual patterns to access information that is not available through other methods (Pradhananga et al., 2016). According to Duchowski (2002), interest in eye tracking methods developed alongside growth in the technology which gave rise to improved performance and greater accessibility. Eye tracking is currently being utilized in marketing research, usability testing, assistive technology, human-computer interactions, e-learning, aviation training,

neuroscience, psychology, medical research, and the improvement of driver safety in transportation.

4.8 Eye Tracking in Construction Engineering

According to Yousefi et al. (2015), there is a limited understanding of the eye tracking applications in the construction industry. Nevertheless, eye tracking technology can be applied during the process of construction to improve craft workers' productivity by improving the format of engineering information they use to perform a task. A study by Pradhananga et al. (2016) looked at leveraging eye tracking technology to study workers' perceptions on a site. It was shown that analysis of workers' perceptions can aid in determining their level of understanding of safety needs and the organization's guidelines. Furthermore, the use of pictures and 3D models can generate variable results. Nevertheless, there is a need for more research on the usage of 2D drawings and basic 3D models in scene perception.

Only a few studies have utilized the eye tracking methods during the process of construction. Most of them have focused on improving construction safety. It should be noted that workers' hazard perceptions play a critical role in general safety on construction sites. Therefore, eye tracking technology has measured employees' perceptions of risk, in addition to its connection with visual attention (Hasanzadeh et al. (2016) and Bhoir et al. (2014)). It is also seen that the use of eye tracking technology has an immense potential to improve safety on construction sites. Fang et al. (2015) analyzed construction workers' recognition of hazards by estimating their visual focus of attention and introduced an automated approach for estimating the visual focus of attention. The test results indicate that this method can efficiently estimate the visual focus of attention in diverse test scenarios.

4.9 Methodology

This study used eye tracking technology to explore the impact of different format of engineering information and spatial cognition on craft workers' performance and eye gaze patterns through a field trial with a model assembly task.

4.9.1 Task Design

The research involved developing model of pipe works with different information formats. The development of the task design in this research built on a study by Goodrum et al. (2016). A piping design (Figure 4.1) with three engineering information formats was developed, which include:

- A 10-sheet set of Traditional, 2D isometric drawings (Figure 4.2);
- A 10-sheet set of 2D isometric drawings with 3D images of the assembly (Figure 4.3);
- A 10-sheet set of 2D isometric drawings with a 3D physical print model (Figure 4.4).

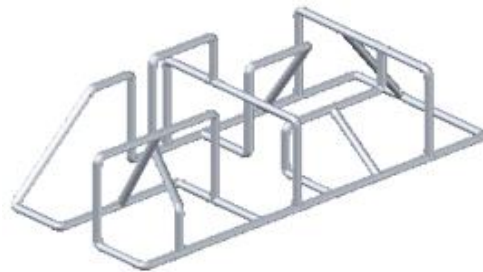

Figure 4.1. Piping Model

Although this study is based on the work of Goodrum et al. (2016), the experimental design presented herein differs in three important ways. First, the experimental design in Goodrum et al (2016) study was relatively simple. The simple designs limited the potential for confusion, rework, and mistakes and reduced the variance of the performance metrics. In this research, the experiment involved a complex design that is similar to what is expected of them on a typical workday. Second, the experiments by Goodrum et al (2016) was limited to 30 minutes to minimize the impact of the experiments on construction operations and also in consideration that the participants

were paid by their employer during the experiment. In this research, participants were paid by the study for one hour of their time in order to allow more time to assemble a complex design. Third, previous research did identify differences due to spatial cognition, but it did not examine how individuals with different spatial cognition interface differently with the information and the assembly when it comes to a complex task. The research described herein addresses this limitation by the use of eye tracking technology. Recording and analyzing eye movements allows better understanding how participants make use of different information formats.

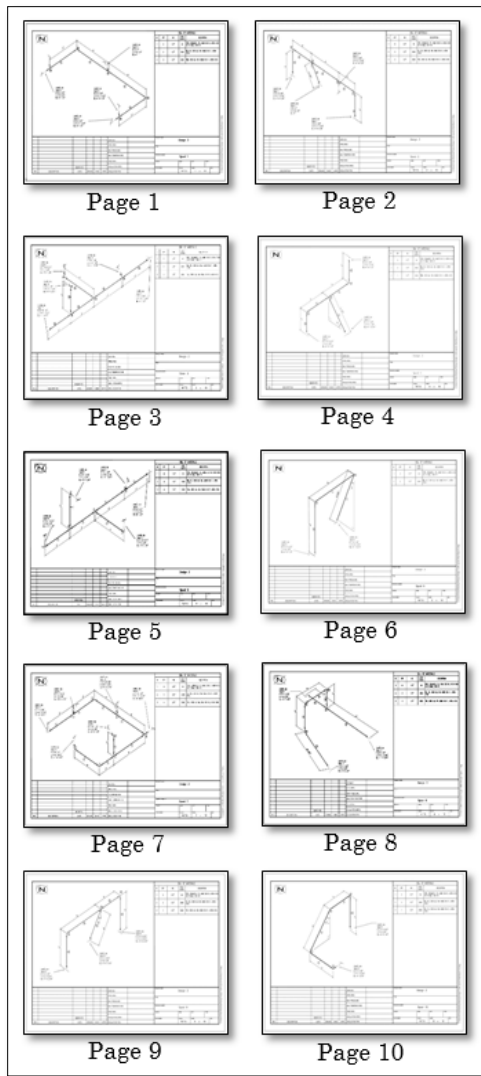

Figure 4.2. 2D Isometric Drawings.

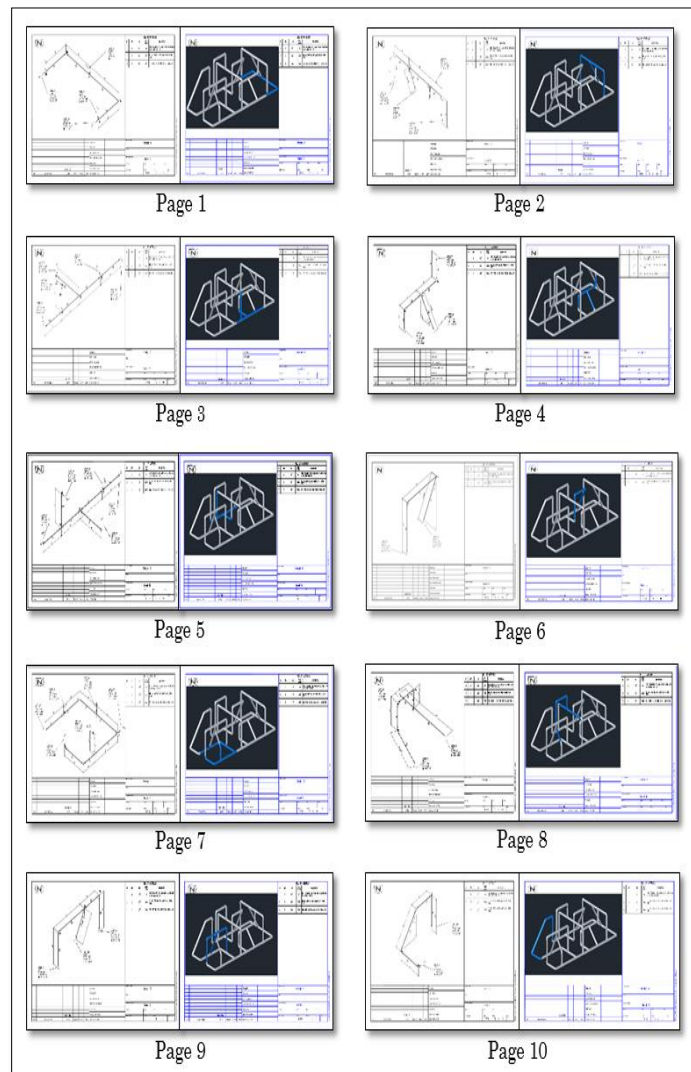

Figure 4.3. 2D Isometric Drawings plus 3D Images

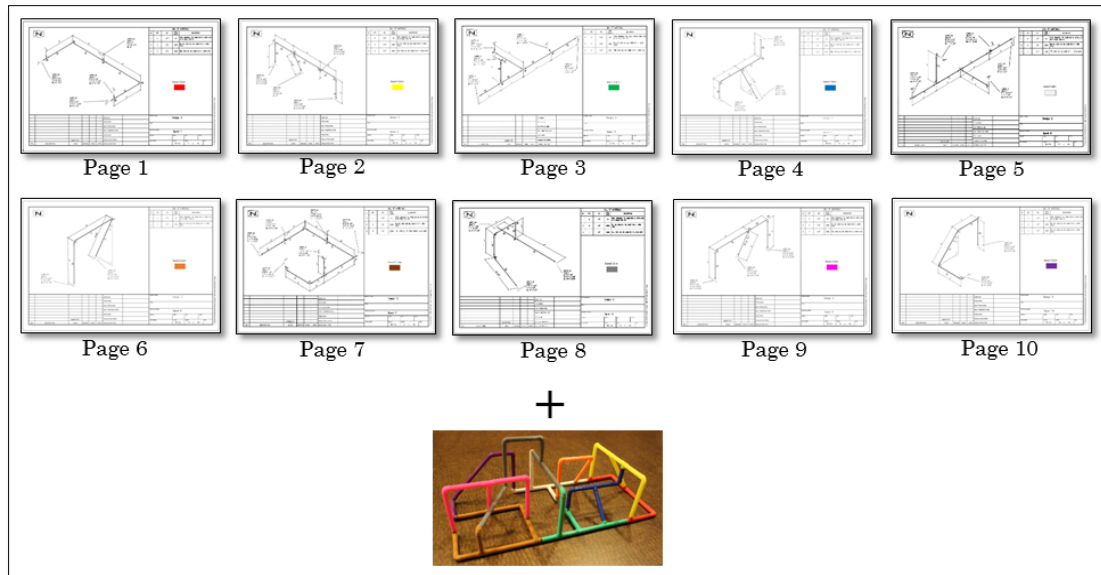

Figure 4.4. 2D Isometric Drawings plus a 3D Physical Model of the Assembly.

4.9.2 Participants

All of the field trial participants were construction workers from the MEP trades. Limiting the participants to the MEP trades is intentional for three reasons. First, isometric drawings are the primary information format provided to the MEP trades. Second, isometrics are one of the most complex information formats provided to all construction-related trades, since the material involves engineered components that must be assembled in a specific order. Third, the MEP trades constitute the largest percentage of direct craft labor and are responsible for a high percentage of material costs on most commercial and industrial projects. As such, the potential for improvement and the impact on industry practice is significant. The study utilized 60 MEP workers from industrial jobsites in the U.S, with most of the participants being member of local pipefitter union chapters in the Colorado Front Range. The participants ranged in age from 18 to 64. Their years of industry experience ranged from 0 to 40 years.

4.9.3 Spatial Cognition Tests

To measure spatial cognition, the Educational Testing Service (ETS) developed two tests for assessing the ability to perceive spatial patterns or maintain orientation with regard to objects in space (Ekstrom et al., 1976). These tests are the card rotation test and the cube comparison test. The card rotation test measures the ability to recognize 2D shapes that have been manipulated (Figure 4.5). The cube comparison test is similar but uses 3D cubes that have been manipulated (Figure 4.6). In the card rotation test, each question shows a 2D shape and eight similar objects. Subjects must determine whether each object has only been rotated (same) or has been flipped and rotated (different). While in the cube comparison test each question shows two cubes marked with a letter on each face; letters are not repeated on a single cube. If the first cube can be turned into a different position to resemble the second cube, the subject marks them as the same. If the first cube cannot be turned to resemble the second due to incorrect relative positions of the letters, the subject marks them as different. To examine the influence of spatial cognition on workers performance, the card rotation and cube comparison tests were administered to each participant in this study.

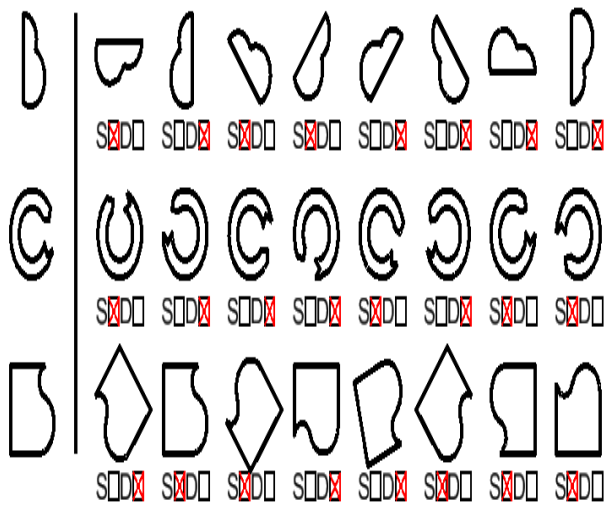

Figure 4.5. Card Rotation Test

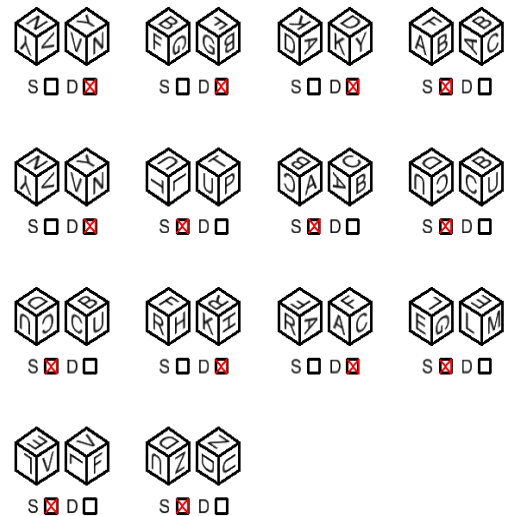

Figure 4.6. Cube Comparison Test

4.9.4 Experiment Method

All field trials were conducted in an office setting on jobsites or a training centers. Each trial involved a single participant from an MEP trade with a total of 60 MEP workers, and each participant used one of the three information formats to guide the assembly of a 1:12 scale model of a piping module (Figure 4.7).



Figure 4.7: Field Trial Experiment

Specifically, 20 workers were given 2D isometric drawings, 20 workers were given 2D isometric drawings supplemented with 3D images of the assembly, and 20 workers were given 2D isometric drawings supplemented with a 3D physical model of the assembly. The tasks included reading the drawings, measuring pipe lengths, joining pipe members to create spools, and assembling the spools to complete the model; a spool is an isometric sheet that contains an assembly drawing of pipes and components; a series of spools comprise an entire assembly design. The pipe is 12.5 mm ($\frac{1}{2}$ in.) diameter polyvinyl chloride (PVC). No welding or pipe bending was required. All field trials were video recorded for analysis purposes. Participants were observed at 30-second intervals. Based on the video, each 30-second interval was assigned to one of three categories; direct work, indirect work, and rework.

- *Direct Work*: the physical act of installing pieces, or measuring pieces in order to assemble the model (i.e., handling the PVC pipe, measuring, and joining the pieces).
- *Indirect Work*: the act of reading plans, visualizing how the model is to be assembled, or any other act that is not Direct Work or Rework (e.g., mentally conceptualizing the model).

- *Rework*: the act of removing any piece that has already been assembled, or reinstalling a piece.

The sum of the categories results in the total time that each participant took to assemble the model (*Time to Completion*). In addition, *the number of errors* were counted at the end of each experiment.

During the experiments, participants' eye movements were recorded using binocular eye tracking glasses (SMI ETG 2 Wireless Analysis Pro) from SensoMotoric Instruments Inc. Eye tracking glasses help to record a number of measures, including number of overall fixations, sequence of fixations, fixations per area of interest (also known as gaze plots), and fixation spatial density (also known as gaze heat maps). Fixation data was aggregated across multiple participants in order to both visually and quantitatively measure how individuals with different spatial cognition and demographics interact with the different engineering information formats and physical assemblies.

Precision and accuracy are significant aspects of eye tracking technology. Accuracy entails the closeness of the gauged gaze positions to an ideal stimulus position, and precision entails closeness of the gauged gaze points to each other and indicates the ability of an eye tracker to constantly regenerate a gaze point measurement. An eye tracker with good precision and accuracy will offer highly valid data since it has the capacity to correctly identify the location of an individual's gaze. To obtain eye tracking analysis with increased accuracy, it is important to understand the factors affecting the accuracy of eye tracking. In accordance with Holmqvist et al. (2011), the precision and accuracy of eye tracking are affected by the properties of the eye tracking glasses, participant characteristics, calibration ability, process of data collection, and position of the eyes in the eye tracking camera.

Calibration is a highly significant procedure that ascertains the recording quality. It guarantees the accurate tracking of the participant's gaze throughout a scene. The calibration process offers the foundation for the correlation between the gaze point in space and the eye position in the camera view. It further creates a plane in space for rendering eye movements. Because this correlation is highly dependent on the entire system setup in addition to varying between subjects, it is imperative to perform calibration prior to each experiment. The accuracy of gaze data has a direct correlation with the success of calibration. During the process of calibration, the participant is asked to look at a number of identified targets (with either 1-point or 3-point). Through the gaze of the participant at a certain target, the user can easily calibrate the participant's eye by adjusting the cursor to the target point.

A key constraint while conducting eye tracking experiments is the calibration of the eye tracking system. While the process of 3-point calibration had been carried out at the onset of most experimental trials, some calibration inconsistency had been observed. This is a result of facial and body movements of the participants, like jaw movements, nose scrunching, and hard squinting, which are capable of affecting the calibration points of the eye tracking glasses. Therefore, the glasses' level of sensitivity to human movement as well as the calibration error may lessen both the precision and the accuracy and lead to outliers in eye tracking data. For the purposes of dealing with this constraint, participants must remain still and seek to curtail head and facial motions during calibration procedures, in addition to preventing glasses movements while the experimental tests are being conducted. Also to ensure that participant eye remained calibrated, researchers should conduct a calibration check at different periods of the experimental tests. In addition, by replaying the eye tracking videos for each participant, researchers may establish the proportion of

participants who fail to have the eye tracking system calibrated for the entire period of the experimental tests.

4.9.5 Eye Tracking Data

SMI BeGaze analysis software was used for analysis of mobile eye tracking data recorded with the eye tracking glasses. BeGaze quantifies and visualizes aggregated multiple participant data. In order to collect data from multiple participants, it was necessary to map gaze data from scene videos to reference images through a process called semantic gaze mapping (SGM). The method involved mapping participants' eye gaze data onto reference images by looking at the gaze cursor in the stimulus video and clicking on the associated position in the reference image. The reference images in this study were the different information formats (Figures 4.2, 4.3, and 4.4).

4.10 Field Trial Results

4.10.1 Effects of Information Format on Craft Worker performance

Results of the field trials, organized by information format, are shown in Table 4.1. An ANOVA analysis was performed to statistically validate the observed influence that the information type has on the performance metrics. The F and p-values describe the statistical significance. The p-values less than 0.05 yield confidence of 95% or greater. Overall, the trials' participants performed best when using either the 2D isometric plus 3D image or the 2D isometric plus 3D physical model and performed worst when using the 2D isometric format alone.

Table 4.1. Field Trial Results by Information

Performance	Info. Format	N	Mean	F	P
Total Time (minute:sec)	2D Isometric	19	0:38:54	11.08	0.00
	2D Isometric + 3D Image	20	0:26:49		
	2D Isometric + 3D Physical	20	0:27:36		
Direct Work %	2D Isometric	20	48.26	27.81	0.00
	2D Isometric + 3D Image	20	70.01		
	2D Isometric + 3D Physical	20	65.40		
Indirect Work %	2D Isometric	20	42.87	23.52	0.00
	2D Isometric + 3D Image	20	26.14		
	2D Isometric + 3D Physical	20	30.42		
Re-work %	2D Isometric	20	8.87	12.26	0.00
	2D Isometric + 3D Image	20	3.76		
	2D Isometric + 3D Physical	20	4.18		
# Errors	2D Isometric	20	1.20	8.32	0.00
	2D Isometric + 3D Image	20	0.30		
	2D Isometric + 3D Physical	20	0.25		

4.10.2 Effects of Information Format on Craft Worker Eye Gaze Patterns.

After the experiments are conducted and all gaze data are mapped onto the reference images, eye tracking metrics, and heat maps, the graphical representations of eye movements over a scene can be developed for further analysis and reporting. Therefore, eye gaze patterns for all participants were mapped onto the three information format images. Tables 4.2–4.4 show the participants’ eye tracking data, such as average fixation time, average number of fixations, and average number of revisits per page (spool) in each information format. Fixations can be interpreted in different ways depending on the context and objective of the study. For example, in this research a higher number of fixations on the drawings indicates that the target area is complex and hard to encode.

To compare the visual representations of participants’ eye gaze patterns in different information formats, heat maps were created for the three information formats. Figure 4.8 illustrates the heat maps of aggregated eye gaze patterns for the 20 participants who used the 2D isometric (iso) format. Figure 4.9 shows the eye gaze patterns for another 20 participants in the 2D

iso+3D images format. Finally, Figure 4.10 shows the eye gaze patterns another 20 participants in the 2D iso + 3D physical model format. The areas of highest eye fixation concentration are shown in red, and areas of relatively lower fixations are shown in gradations from yellow to green. The figures indicate that the 2D isometric format had the highest eye fixation.

Table 4.2. Eye Tracking Data in the 2D Isometric Format.

2D Isometric				
Stimulus	N	Avg. Revisits	Avg. # of Fixation	Avg. Fixation Time (m)
Spool 1 (Page 1)	20	16	213.6	1.11
Spool 2 (Page 2)		15.3	373.2	1.96
Spool 3 (Page 3)		20.2	446	2.14
Spool 4 (Page 4)		14.8	203.3	0.94
Spool 5 (Page 5)		24.6	255.3	1.13
Spool 6 (Page 6)		11	141.1	0.65
Spool 7 (Page 7)		24	376.8	1.72
Spool 8 (Page 8)		20.7	294.7	1.35
Spool 9 (Page 9)		12.5	159.4	0.69
Spool 10 (Page10)		7.9	102.8	0.43
Total		167	2566.2	12.12

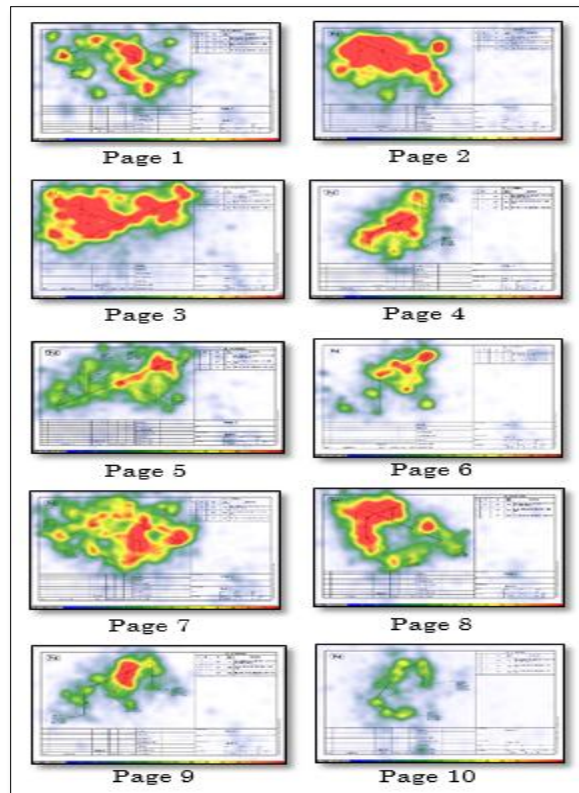

Figure 4.8. Heat maps for 20 Participants in the 2D Isometric Format.

Table 4.3. Eye Tracking Data in the 2D Isometric plus 3D Image Format

2D Isometric + 3D Image				
Stimulus	N	Avg. Revisits	Avg. # of Fixation	Avg. Fixation Time (m)
Spool 1 (Page 1)	20	3.5	48.6	0.24
Spool 1 in 3D CAD		2.5	19.8	0.09
Spool 2 (Page 2)		3.5	92.6	0.51
Spool 2 in 3D CAD		3.2	35.3	0.18
Spool 3 (Page 3)		3.6	125	0.58
Spool 3 in 3D CAD		7.2	68.2	0.33
Spool 4 (Page 4)		3.4	75	0.36
Spool 4 in 3D CAD		2.7	24.9	0.11
Spool 5 (Page 5)		7.3	99.8	0.46
Spool 5 in 3D CAD		6	51.4	0.25
Spool 6 (Page 6)		1.2	33.8	0.16
Spool 6 in 3D CAD		2.1	18.4	0.09
Spool 7 (Page 7)		7.2	136	0.61
Spool 7 in 3D CAD		9.4	83.5	0.40
Spool 8 (Page 8)		7.8	120.2	0.59
Spool 8 in 3D CAD		7.5	70.3	0.36
Spool 9 (Page 9)		3.9	54.4	0.25
Spool 9 in 3D CAD		4.2	33	0.15
Spool 10 (Page 10)		2.3	37.1	0.17
Spool 10 in 3D CAD		3.1	20.2	0.09
Total		89.9	1174.6	5.98

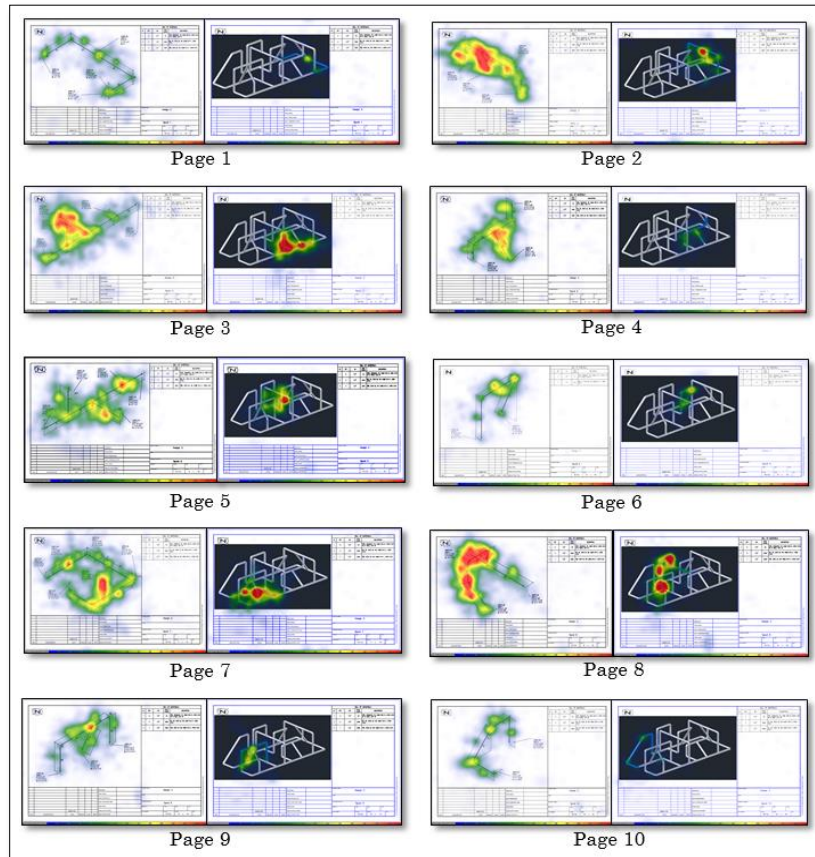

Figure 4.9. Heat maps for 20 Participants in the 2D Isometric plus 3D Image Format.

Table 4.4. Eye Tracking Data in the 2D Isometric plus 3D Physical Format.

2D Isometric + 3D Physical Model				
Stimulus	N	Avg. Revisits	Avg. # of Fixation	Avg. Fixation Time (m)
Spool 1 (Page 1)	20	6.7	91.4	0.41
Spool 1 in 3D physical		19	37.8	0.15
Spool 2 (Page 2)		9	132.3	0.62
Spool 2 in 3D physical		22	47.1	0.19
Spool 3 (Page 3)		9.5	146.4	0.62
Spool 3 in 3D physical		26.8	57.7	0.23
Spool 4 (Page 4)		6.7	93.2	0.43
Spool 4 in 3D physical		20	37.5	0.15
Spool 5 (Page 5)		13.7	140.8	0.57
Spool 5 in 3D physical		32.4	72.9	0.28
Spool 6 (Page 6)		2.5	43.6	0.19
Spool 6 in 3D physical		24	38.2	0.14
Spool 7 (Page 7)		15.7	181.9	0.73
Spool 7 in 3D physical		34.7	84.1	0.31
Spool 8 (Page 8)		8.9	116.4	0.51
Spool 8 in 3D physical		32.2	58.2	0.21
Spool 9 (Page 9)		4.1	57.3	0.24
Spool 9 in 3D physical		27.6	47.2	0.17
Spool 10 (Page 10)		4.7	37.1	0.15
Spool 10 in 3D physical		16.1	23.8	0.09
Total		336.3	1544.9	6.38

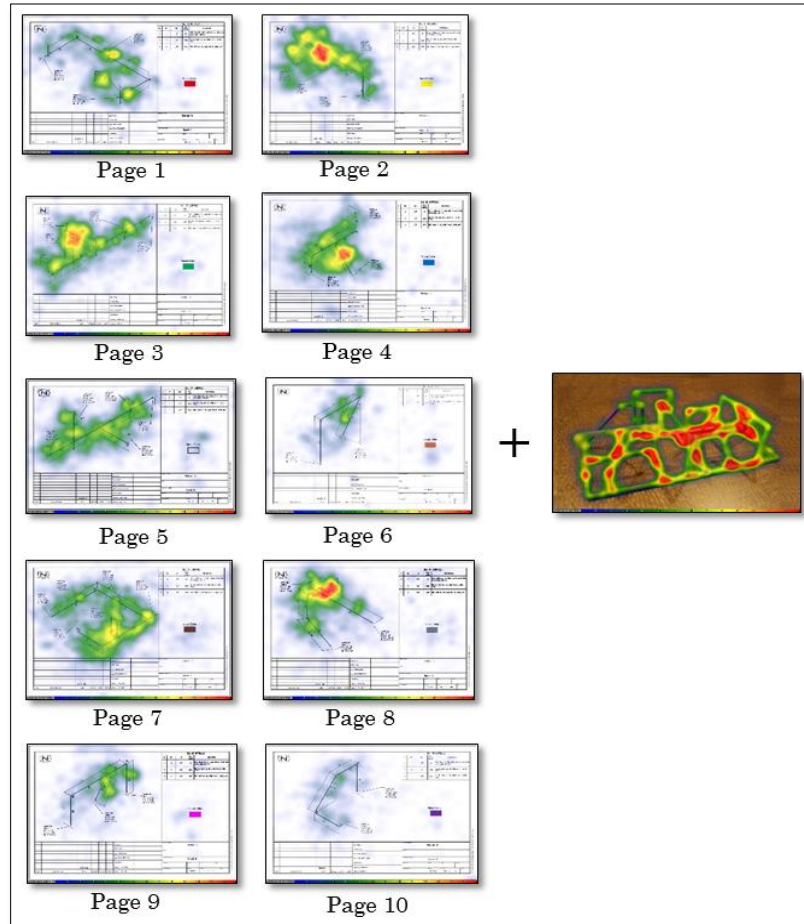

Figure 4.10. Heat maps for 20 Participants in the 2D Isometric plus 3D Physical Format.

The eye tracking results visually indicate that there were different gaze patterns in each information format. An ANOVA statistically validates the observed influence that the information type had on the eye tracking metrics (i.e., fixation time, number of fixations and number of revisits), where p-values less than 0.05 yield confidence of 95% or greater. The eye tracking data, controlled by information format, are shown in Table 4.5. Among the observed participants, the eye gaze patterns substantially and statistically differ by information format. Participants who used either the 2D isometric format plus 3D images or the 2D isometric format plus a 3D physical model performed the best (based on time to completion, rework, errors, and direct and indirect time) and had less fixation time and fewer fixations on the drawings than those who used the 2D isometric format. In addition, participants who used the 2D isometric plus 3D physical model had more revisits than those who used other formats.

Table 4.5. Eye Tracking Metrics by Information Format.

Eye Tracking Data	Info. Format	N	Mean	F	P
Fixation Time (minute)	2D Isometric	20	12.12	22.76	0.00
	2D Isometric + 3D Image	20	5.96		
	2D Isometric + 3D Physical	20	6.38		
Number of Fixation Points	2D Isometric	20	2566	22.08	0.00
	2D Isometric + 3D Image	20	1243		
	2D Isometric + 3D Physical	20	1545		
Revisits Number	2D Isometric	20	167	28.63	0.00
	2D Isometric + 3D Image	20	91		
	2D Isometric + 3D Physical	20	336		

4.10.3 Effects of Information Format and Spatial Cognition on Craft Worker performance and Eye Gaze Patterns.

The card rotation and cube comparison tests were administered to explore the influence of information format and spatial cognition on craft worker performance and eye gaze patterns when using different engineering information formats. Higher scores indicate higher spatial cognition.

The total score in the card rotation test is 40 and in the cube comparison test is 14. To establish comparison groups, the scores on the cube comparison test were scaled to be of equal weight to the scores on the card rotation test. After both scores were scaled out of 40 points, they were added together to create a composite spatial cognition score. Participants were then divided into low or high spatial cognition abilities groups based on their composite spatial cognition score when compared to the average of the entire population who participated in the field trials. Participants who scored below the average of the composite spatial cognition scores were placed in the low composite spatial cognition group. Those who scored at or above the average were placed in the high composite spatial cognition group.

The heat maps were also created for the three information formats to compare visual representations of the eye gaze patterns of the high and low spatial cognition participants. As an example, the heat map of spool (page) number 5 for the high and low spatial cognition participants in all the information formats are shown in the following figures. Figures 4.11–4.12 illustrate the heat map of spool number 5 in the 2D isometric format for high and low spatial cognition participants, respectively. Figures 4.13–4.14 show the heat map of spool number 5 in the 2D iso plus 3D images format for the high and low spatial cognition participants, respectively. Finally, Figures 4.15–4.16 also show the heat map of spool number 5 in the 2D iso plus the physical model format for the high and low spatial cognition participants, respectively. Once again, the areas of highest eye fixation concentration are shown in red. As noted, the low spatial cognition participants had more eye fixation in the 2D isometric format when compared to the high spatial cognition participants. Additionally, participants with lower spatial cognition relied on the 3D information more than the high spatial cognition participants.

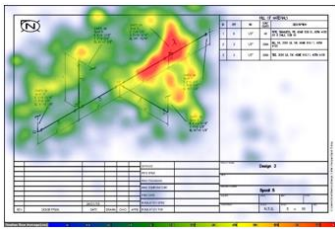

Figure 4.11. Heat Map of Spool Number 5 in the 2D isometric for Higher Spatial Cognition Group

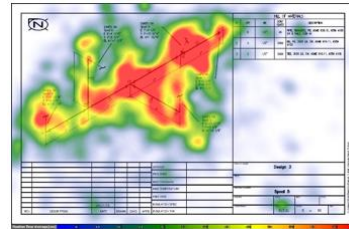

Figure 4.12. Heat Map of Spool Number 5 in the 2D isometric for Lower Spatial Cognition Group



Figure 4.13. Heat Map of Spool Number 5 in the 2D isometric + 3D image for Higher Spatial Cognition Group



Figure 4.14. Heat Map of Spool Number 5 in the 2D isometric + 3D image for Lower Spatial Cognition Group

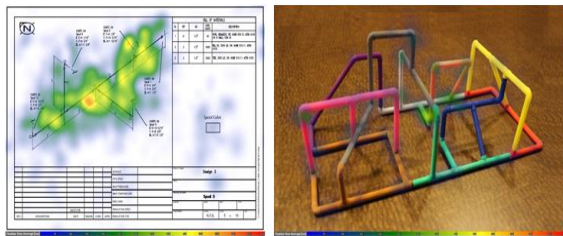

Figure 4.15. Heat Map of Spool Number 5 in the 2D isometric + 3D physical model for Higher Spatial Cognition Group

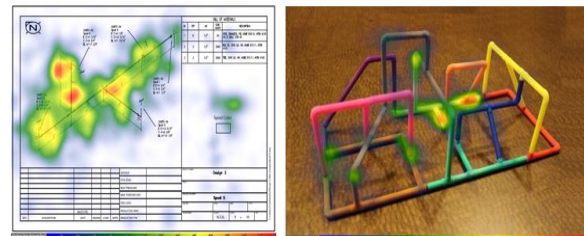

Figure 4.16. Heat Map of Spool Number 5 in the 2D isometric + 3D physical model for Higher Spatial Cognition Group

The results of the composite spatial cognition were used to control for differences among the individuals' spatial cognition, performance, and eye tracking data when using different engineering formats. An ANOVA analysis was performed to statistically validate the observed influence that the information type and spatial cognition had on worker performance and eye tracking metric.

4.10.3.1 Effects of Composite Spatial Cognition Scores on Worker Performance, Controlling for Information Format.

The results of the field trials comparing the performance of high and low spatial cognition participants who were given the same engineering information, are shown in Table 4.6. When the participants used the conventional 2D isometric drawings to complete the assembly, participants with higher spatial cognition performed better than participants with lower spatial cognition in all the performance metrics with strong statistically significant differences.

In contrast, the results were dramatically different when participants used the 2D isometric drawings plus 3D image or 3D physical model. Both high and low spatial cognition participants performed almost equally in all performance metrics with no statistically significant differences, except in the number of errors when they used 2D isometric drawings plus 3D physical model. These results indicate that 2D isometric drawings plus 3D image or 3D physical model allowed participants with lower to perform as efficiently and effectively as higher spatial cognition results.

Table 4.6. Performance Metrics by Composite Spatial Cognition Results Controlling for Information Format.

Performance	L/H Spatial Cognition Score	2D Isometric				2D Isometric + 3D Image				2D Isometric + 3D Physical			
		N	Mean	F	p	N	Mean	F	p	N	Mean	F	p
Total Time (minute:sec)	Low Spatial Cognition Score	8	0:46:07	7.92	0.01	10	0:27:21	0.09	0.77	10	0:29:48	1.80	0.20
	High Spatial Cognition Score	11	0:33:39			10	0:26:16			10	0:25:25		
Direct Work %	Low Spatial Cognition Score	9	39.05	13.59	0.00	10	67.97	1.77	0.20	10	65.07	0.03	0.86
	High Spatial Cognition Score	11	55.80			10	72.23			10	65.73		
Indirect Work %	Low Spatial Cognition Score	9	48.12	6.55	0.02	10	27.72	1.08	0.31	10	30.68	0.02	0.88
	High Spatial Cognition Score	11	38.57			10	24.57			10	30.16		
Re-work %	Low Spatial Cognition Score	9	12.83	15.09	0.00	10	4.32	2.76	0.11	10	4.25	0.01	0.92
	High Spatial Cognition Score	11	5.63			10	3.20			10	4.11		
# Errors	Low Spatial Cognition Score	9	1.89	6.52	0.02	10	0.30	0.00	1.00	10	0.50	5.00	0.04
	High Spatial Cognition Score	11	0.64			10	0.30			10	0.00		

4.10.3.2 Effects of Composite Spatial Cognition Scores on Eye Gaze Pattern, Controlling for Information Format.

The results of the field trials comparing the eye tracking data of high and low spatial cognition participants who were given the same engineering information are shown in Table 4.7. The information format and spatial cognition significantly influenced workers' eye gaze patterns. When the participants used the conventional 2D isometric drawings to complete the assembly, participants with higher spatial cognition had less eye fixation time and fewer fixations and revisits than participants with lower spatial cognition.

These findings highlight the difference in performance between high and low spatial cognition groups that has been discovered in this research and previous studies; participants with higher spatial cognition performed better than participants with lower spatial cognition when using the conventional 2D isometric drawings (Goodrum et al., 2016; Sweany et al., 2016). The performance difference between high and low spatial cognition groups is associated with the number of fixation points and fixation time on the 2D isometric drawings. Participants with lower spatial cognition experienced longer fixation times, a higher number of fixations and revisits, and lower performance than participants with higher spatial cognition.

In contrast, the results were dramatically different when participants used the 2D isometric drawings plus a 3D image or 3D physical model. Both high and low spatial cognition participants had almost the same results in all eye tracking metrics with no statistically significant differences, except in the number of revisits in the 2D isometric drawings plus the 3D physical model. In addition, when 2D + 3D information was provided, participants with lower spatial cognition performed as efficiently and effectively as individuals with higher spatial cognition, as discovered in this research and previous studies (Goodrum et al., 2016; Sweany et al., 2016).

Table 4.7. Eye tracking Metrics by Spatial Cognition, Controlling for Information Format.

Eye Tracking Data	L/H Spatial Cognition Score	2D Isometric				2D Isometric + 3D Image				2D Isometric + 3D Physical			
		N	Mean	F	p	N	Mean	F	p	N	Mean	F	p
Fixation Time (minute)	Low Spatial Cognition Score	9	14.83	7.22	0.02	10	6.09	0.08	0.77	10	6.87	0.85	0.37
	High Spatial Cognition Score	11	9.91			10	5.83			10	5.89		
Number of Fixation Points	Low Spatial Cognition Score	9	3127	8.27	0.01	10	1358	1.87	0.19	10	1663	0.93	0.35
	High Spatial Cognition Score	11	2107			10	1128			10	1427		
Revisits Number	Low Spatial Cognition Score	9	209	4.77	0.04	10	95	0.11	0.75	10	418	8.15	0.01
	High Spatial Cognition Score	11	132			10	87			10	254		

4.10.3.3 The relationship between Spatial Cognition and 3D Information.

This study found that individuals with lower spatial cognition rely more on 3D information. When the 2D + 3D information format was provided, participants with lower spatial cognition experienced longer fixation times and a higher number of fixations and revisits on the 3D information than their counterparts with high spatial cognition. In addition, they were able to complete the model assembly as efficiently and effectively as participants with higher spatial cognition.

To explain the relationship between spatial cognition and 3D information in the 2D iso+3D images format, the average numbers of fixation points for high and low spatial cognition participants, respectively, were plotted for each spool after controlling for each side in the 2D iso+3D images format (Figure 4.17). The graph on the left illustrates the average number of fixation points of the high (H) and low (L) spatial cognition participants when using the 2D iso drawings side of the 2D+3D image format. The graph on the right shows the average number of fixation points of high (H) and low (L) spatial cognition participants when using the 3D images side of the 2D+3D image format. As shown in the figure for the 2D iso side, the high and low

spatial cognition participants had almost the same average number of fixation points for each of the 10 spools. However, for each of the 10 spools in the 3D images, the low spatial cognition participants consistently required a greater number of fixation points compared to the high spatial cognition participants, especially for more complex spools, such as spools 3, 5, and 8, which showed a complicated group of pipes whose orientation was defined by two or more vectors.

The statistical results of comparing the eye tracking data of the high and low spatial cognition participants controlling for the use of 2D iso versus 3D images in the 2D iso+3D images format are shown in Table 4.8. There were no statistically significant differences between high and low spatial cognition participants in all eye tracking metrics on the 2D iso side of the 2D iso+3D images format. However, there were statistically significant differences between high and low spatial cognition participants in all eye tracking metrics on the 3D images side; individuals with lower spatial cognition were observed to have statistically significant and substantially higher numbers of fixations, fixation counts, and revisits compared to individuals with higher spatial cognition.

Table 4.8. Eye Tracking Metrics by Spatial Cognition, Controlling for the use of 2D Iso versus 3D Images in the Iso+3D Image Format.

		2D Isometric + 3D Image							
Eye Tracking Data	L/H Spatial Cognition Score	2D Iso side of all spools				3D image side of all spools			
		N	Mean	F	P	N	Mean	F	P
Fixation Time (minute)	Low Spatial Cognition Score	10	1.24	0.35	0.56	10	0.86	17.96	0.00
	High Spatial Cognition Score	10	1.40			10	0.26		
Fixation Count	Low Spatial Cognition Score	10	265	0.14	0.71	10	164	21.13	0.00
	High Spatial Cognition Score	10	246			10	47		
Revisits Number	Low Spatial Cognition Score	10	119	0.66	0.43	10	79	13.76	0.00
	High Spatial Cognition Score	10	103			10	28		

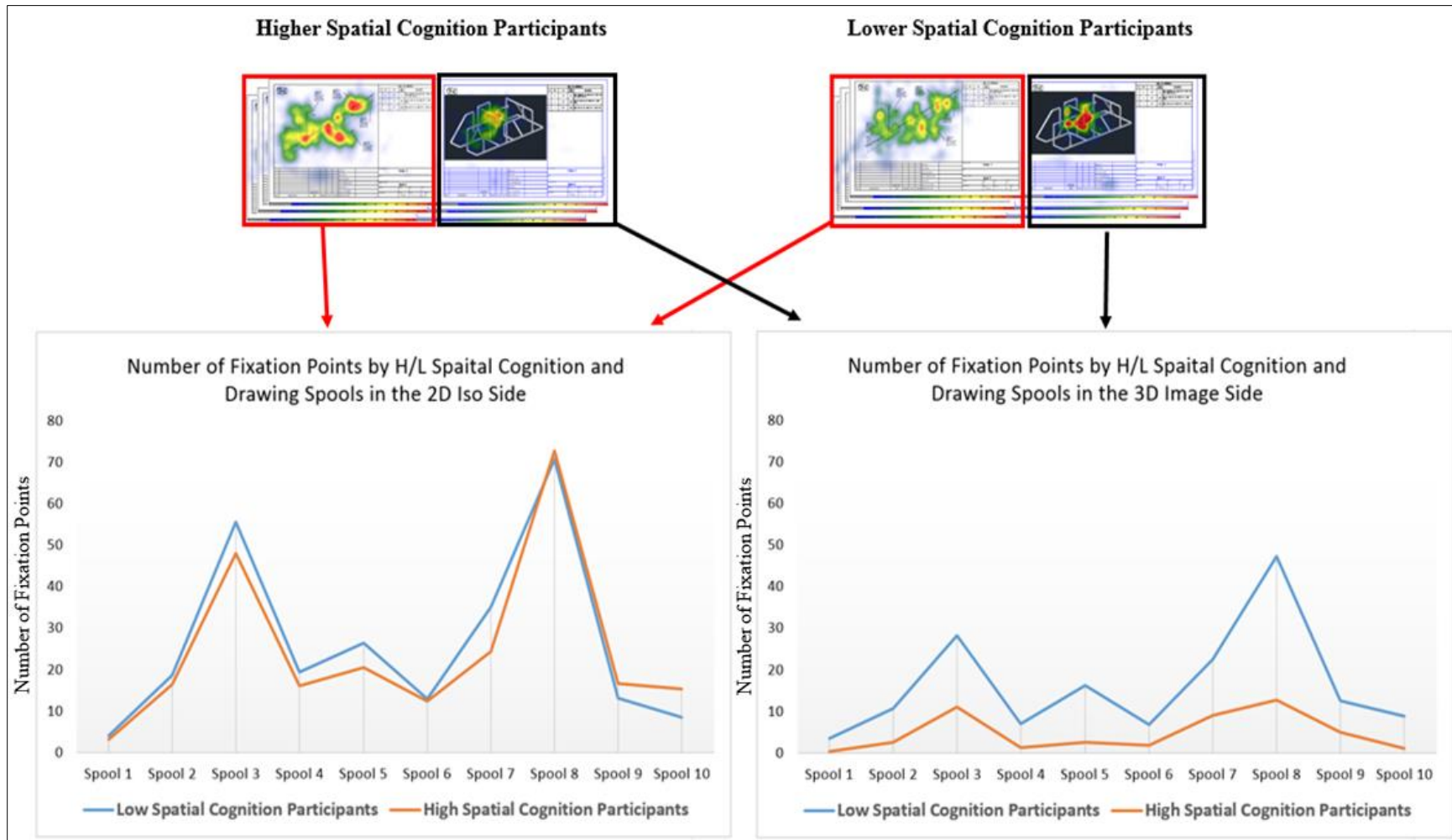

Figure 4.17. Number of Fixation Points for Spools 1 through 10 by H/L Spatial Cognition Group in the 2D+3D Image Format

The same process was used in the 2D+3D physical model format to explain the relationship between spatial cognition and 3D Information. The average numbers of fixation points for high and low spatial cognition participants were plotted for each spool after controlling for each side in the 2D iso+3D physical format (Figure 4.18). As shown, the high and low spatial cognition participants were observed to have almost the same average number of fixation points on the 2D iso side. However, for each of the 10 spools in the 3D images side, the low spatial cognition participants also consistently required a greater number of fixation points compared to the high spatial cognition participants.

Additionally, there were no statistically significant differences between high and low spatial cognition participants for any eye tracking metrics on the 2D iso side. However, there were statistically significant differences between high and low spatial cognition participants in all eye tracking metrics when using the 3D physical model, Table 4.9.

Table 4.9. Eye Tracking Metrics by Spatial Cognition, Controlling for the use of 2D Iso vs. 3D Model in the Iso+3D Physical Format.

		2D Isometric + 3D Physical							
Eye Tracking Data	L/H Spatial Cognition Score	2D Iso side of all spools				3D physical of all spools			
		N	Mean	F	P	N	Mean	F	P
Fixation Time (minute)	Low Spatial Cognition Score	10	1.23	0.01	0.93	10	1.41	10.16	0.01
	High Spatial Cognition Score	10	1.21			10	0.76		
Fixation Count	Low Spatial Cognition Score	10	263	0.00	0.96	10	368	7.66	0.01
	High Spatial Cognition Score	10	266			10	204		
Revisits Number	Low Spatial Cognition Score	10	123	0.01	0.94	10	236	8.58	0.01
	High Spatial Cognition Score	10	121			10	127		

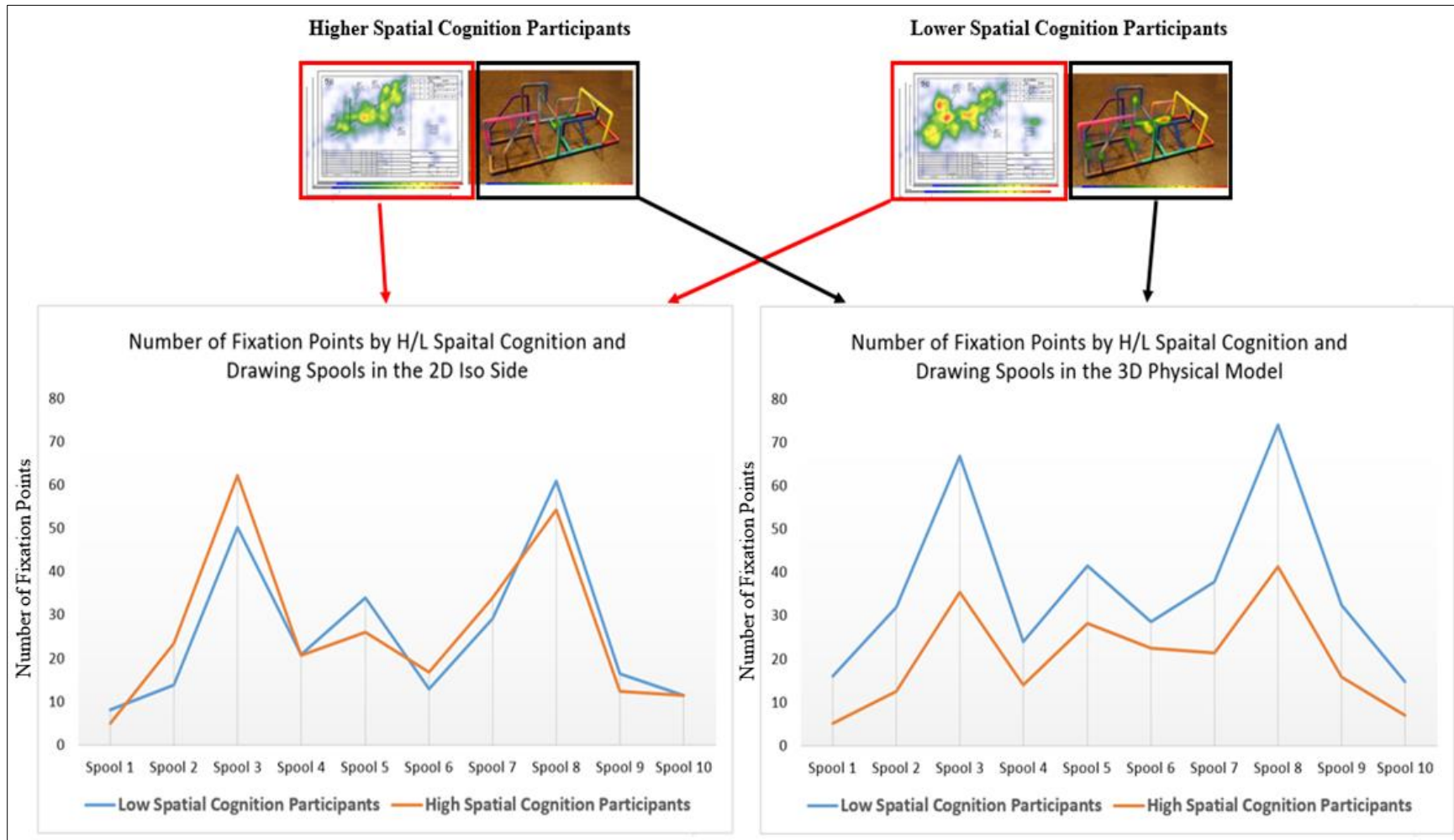

Figure 4.18. Number of Fixation Points for Spools 1 through 10 by H/L Spatial Cognition Group in the 2D+3D Physical Format

The similar results from the two formats (the 2D+3D images and 2D+3D physical model formats) reveal that the low spatial cognition groups used information differently. When provided with 3D information, individuals with lower spatial cognition were able to work as efficiently (based on time to completion, reworks, and errors) than their counterparts with higher spatial cognition, but they relied more on 3D information to complete their work.

4.11 Experiment Limitations

The limitation of this research is the scale of the model assembly task. Pipe used on most industrial projects is often 152.4 mm (6 in.) in diameter or larger, which is significantly larger than the 12.7 mm (0.5 in.) PVC pipe used in this study. Although fitting pipe requires more tasks (e.g., welding, material and equipment handling, and bolting), this research model focused only on measuring and assembling pipes through reading and understanding engineering drawings, which is the most important task in the industrial pipefitting. Also this research focused on two factors that affect worker productivity; information format and spatial cognition. However, construction sites are dynamic environments with numerous factors affecting craft workers' performance, such as information, equipment, tools, materials, rework, supervision, congestion, safety, weather, sequencing, individual skills of workers, size of components, specification, work content, design features, and work scope (Thomas and Sakarcan 1994). The authors readily acknowledge that these and other jobsite factors would likely influence results, if the field trials were conducted on a construction worksite versus being conducted in a controlled setting.

4.12 Conclusion

The primary contribution from the paper to the body of knowledge is the new discoveries found regarding the relationship between eye gaze patterns, information format, and spatial cognition in execution of a complex task. Information format and level of spatial cognition significantly

influenced workers' eye gaze patterns. Additionally, spatial cognition groups use 2D and 3D information differently.

The 3D information offset the effects of lower spatial cognition. When the 2D + 3D information was provided, participants with lower spatial cognition experienced longer fixation times and a higher number of fixations and revisits on the 3D information than their counterparts with high spatial cognition. They were also able to complete the model assembly as efficiently and effectively as participants with higher spatial cognition. A list of the statistically proven results is provided in Table 4.10.

Table 4.10. Trends Statistically Proven.

	Hypothesis	Result
1	There are different eye gaze patterns when using different information formats	Participants who used the 2D isometric format had more eye fixation time and number with less performance when compared to participants used the 2D+3D images or 2D+3D physical model.
2	The performance improvement when using engineering information format is associated to eye gaze patterns.	Participants who used either the 2D isometric format plus 3D image or the 2D isometric format plus 3D physical model performed better and had less eye fixation time and few number of fixation in the drawings than those who used the 2D isometric.
3	Differences in gaze patterns are associated with differences in spatial cognition	The performance differences between high and low spatial cognition groups is associated with the number of eye fixation points and fixation time on the 2D isometric drawings. Lower spatial cognition had more fixation time with high number of fixation and revisit than participants with a higher spatial cognition.
4	Workers with lower spatial cognition tend to fixate more in 3D information compared to workers with higher spatial cognition.	When provided with 3D information, participants with a lower spatial cognition are able to work as efficiently (based on time to completion, rework and errors) as their counterparts with a higher spatial cognition, but they rely greater on 3D information to do their work.

Investigating eye movement provides useful information about the gaze pattern of the subject, based on where and what the subject is looking at. It gives insight into reasoning, problem solving, and search strategy. In this research, recording and analyzing workers' eye movements helped to better understand how workers make use of the format of engineering deliverables and also how the engineering information format can control the differences in eye gaze patterns and improve human performance in spatially complex tasks.

The findings can help guide construction companies understanding of how existing engineering deliverables can be improved and augmented to assist craft workers with varying spatial cognition and demographics to both improve their efficiency (speed) and effectiveness (reduced errors) in planning and executing construction tasks.

References

- Bhoir, S., Hasanzadeh, S., Esmaeili, B., Michael, D., Dodd, and Fardhosseini, M.S. (2014). "Measuring Construction Workers' attention using Eye tracking Technology." *Construction Specialty Conference*, (222), 1-6.
- Bowden, S., Dorr, A., Thorpe, A., Anumba, C. (2006). "Mobile ICT Support for Construction Process Improvement". *Automation in Construction* Vol. 15 (5). 664–676.
- Bruneau, D., Sasse, M. A., & McCarthy, J. D. (2002). "The eyes never lie: The use of eye tracking data in HCI research." In *Proceedings of the CHI'02 Workshop on Physiological Computing*. NY: ACM Press.
- Dadi, G. B., Goodrum, P. M., Taylor, T. R., and Carswell, C. M. (2014a). "Cognitive Workload Demands Using 2D and 3D Spatial Engineering Information Formats". *Journal of Construction Engineering and Management*, 140(5).
- Dadi, G. B., Goodrum, P. M., Taylor, T. R., & Maloney, W. F. (2014b). "Effectiveness of communication of spatial engineering information through 3D CAD and 3D printed models". *Visualization in Engineering*, 2(1), 1-12.
- Dadi, G. B., Taylor, T. R., Goodrum, P. M., & Maloney, W. F. (2014c). "Performance of 3D computers and 3D printed models as a fundamental means for spatial engineering information visualization". *Canadian Journal of Civil Engineering*, 41(10), 869-877.
- Dai, J., Goodrum, P. M., and Maloney, W. F. (2009a). "Construction Craft Worker' Perceptions of the Factors Affecting Their Productivity". *Journal of Construction Engineering and Management*, (135), 217–226.
- Duchowski, A. (2002). "A breadth-first survey of eye-tracking applications." *Behavior Research Methods, Instruments, & Computers*, 34(4), 455-470. <http://dx.doi.org/10.3758/bf03195475>
- Fang, Y., Cho, Y., & Chen, J. (2015). "Analyzing Construction Workers' Recognition of Hazards by Estimating Visual Focus of Attention". *Automation in Construction*. <http://dx.doi.org/10.1016/j.autcon.2016.08.025>
- Goldberg, H. J., & Kotval, X. P. (1999). "Computer interface evaluation using eye movements: Methods and constructs" *International Journal of Industrial Ergonomics*, 24, 631-645.
- Goldberg, H. J., & Wichansky, A. M. (2003). "Eye tracking in usability evaluation: A practitioner's guide."

- Goodrum, P. M., and Miller, J. M. (2015). "Innovative delivery methods of information to the crafts. Construction Industry Institute", *Univ. of Texas at Austin*, Austin, TX.
- Goodrum, P., Miller, J., Sweany, J., and Alruwaythi, O. (2016). "Influence of the Format of Engineering Information and Spatial Cognition on Craft-Worker Performance". *Journal of Construction Engineering and Management*, Vol. 142, No. 9.
- Hasanzadeh, S., Esmaili, B., and Dodd, M (2016). "Measuring Construction Workers' Real-Time Situation Awareness Using Mobile Eye-Tracking". *Construction Research Congress*, 8(8), 621.
- Holmqvist, K. (2011). "Eye tracking: A comprehensive guide to methods and measures". Oxford: Oxford University Press.
- Just, M. A., & Carpenter, P. A. (1976). "Eye fixations and cognitive processes". *Cognitive Psychology*, 8, 441-480.
- Liberda, M., Ruwanpura, J., & Jergeas, G. (2003). "Construction Productivity Improvement: A Study of Human, Management and External Issues". ASCE. *Construction Research Congress*. 1-8. 10.1061/40671(2003)5
- Marshall, S. (2000). "Method and apparatus for eye tracking and monitoring pupil dilation to evaluate cognitive activity". U.S. *Patent* 6,090,051, July 2000.
- Naoum, S. G., (2016). "Factors influencing labor productivity on construction sites: A state of the art literature review and a survey". *International Journal of Productivity and Performance Management*. ISSN: 1741-0401
- Poole, A., & Ball, L. (2005). "Eye Tracking in Human-Computer Interaction and Usability Research: Current Status and Future Prospects". Retrieve from: <http://citeseer.ist.psu.edu/viewdoc/download?doi=10.1.1.95.5691&rep=rep1&type=pdf>
- Poole, A., & Ball, L. (2007). "The Current Status of Computer-Assisted Telephone Interviewing: Recent Progress and Future Prospects". *Psychological Methods & Research*, 12(2), 119-142.
- Pradhananga, N., Jianu, R., & Orabi, W. (2016). "Eye-tracking Technology for Construction Safety: A feasibility Study". *AMR*, 952, 347-350. <http://dx.doi.org/10.4028/www.scientific.net/amr.952.347>
- Rayner, K., & Pollatsek, A. (1989). "The psychology of reading". Englewood Cliffs, NJ: Prentice Hall.
- Robert, J. K., Jacob, D., & Karn, S. (2013). "Eye Tracking in Human-Computer Interaction and Usability Research: Ready to Deliver the Promises". *International Journal of Human-Computer Interaction*, (4), 574-597.

- Sweany, J., Goodrum, P., Miller, J. (2016). "Analysis of empirical data on the effects of the format of engineering deliverables on craft performance". *Automation in Construction*, Volume 69. (2016) 59-67
- Yousefi, H., Karan, E., Mohammadpour, A., & Asadi, S. (2015). "Implementing Eye Tracking Technology in the Construction Process". *Associated Schools of Construction*, 2(1), 48. <http://dx.doi.org/10.4103/2277-9183.122445>

CHAPTER 5: CONCLUSIONS

This dissertation utilized an arrangement of field trials taking into account experimental designs to investigate the interconnection and interactions between information formats, craft demographics, and individual spatial cognition on their combined impact on craft-worker performance. Understanding this interface not only enhances the construction craft-workers' performance but also opens up the chances for more extensive transformative discoveries of how to integrate the information interface with people in a more natural way.

5.1 Contributions

The dissertation's primary contribution to the body of knowledge is a better understanding of the influence that format of engineering information, spatial cognition, and demographics have on craft worker performance in a complex task execution.

The body of this dissertation contains three papers (chapters 2, 3, and 4). The first paper (chapter 2) presented in this dissertation utilized empirical data collection methods and quantitative analysis to examine how various design complexity and the use of different engineering information formats influence craft worker performance in task execution. The paper's primary contribution to the body of knowledge is the strong statistical significance found between the level of design complexity and the format of engineering information. The results in the paper indicate that as design complexity increased, the effects of using different engineering information formats increased as well. Additionally, different types of 3D information produce very similar results in task performance.

The second paper (chapter 3) offers an even more relevant advancement in knowledge regarding the correlations between engineering information formats, spatial cognition, and

demographics when performing a complex task. This paper utilized a complex model assembly to examine how the use of different engineering information formats, worker spatial cognition, and demographics influence the performance in task execution. The paper's primary contribution is identifying that information format, spatial cognition, and demographics play a significant role in construction craft productivity.

Finally, the third paper (chapter 4) represents the first attempt to explore how eye gaze patterns are related to the performance improvement of construction craft workers when using different engineering information formats, and how spatial cognition abilities influence eye gaze patterns. This paper utilized eye tracking technology to explore the impact of different formats of engineering information and spatial cognition on craft workers' performance and eye gaze patterns through a field trial with a complex model assembly task that developed in the first paper (chapter 2). The paper's primary contribution to the body of knowledge are new discoveries regarding the relationship between eye gaze patterns, information format, and spatial cognition in a complex task execution. The information format and spatial cognition significantly influenced workers' eye gaze patterns. Additionally, spatial cognition groups use 2D and 3D information differently.

The three papers' discoveries have a significant understanding of how existing engineering deliverables can be improved and augmented to assist craft workers with varying spatial cognition and demographics to both improve their efficiency (speed) and effectiveness (reduced errors) in planning and executing construction tasks. Table 5.1 summarizes the research questions and the results of the dissertation by paper.

Table 5.1: Research Questions and Results

Paper	Research questions	Results
<p>Paper 1 (Chapter 2)</p>	<ul style="list-style-type: none"> • How do craft workers perform in different formats of engineering information? • How does increasing design complexity interact with varying information formats in terms of workers performance? • How do craft-workers perform in using different types of 3D engineering information? 	<ul style="list-style-type: none"> • Different formats of information influence task performance differently. • The influence of different information formats on task performance become stronger when increasing design complexity. • Different types of 3D information produce very similar results in task performance.
<p>Paper 2 (Chapter 3)</p>	<ul style="list-style-type: none"> • In what ways are the relative utility of different formats contingent on the spatial abilities of users? • How does age and year of experience affect craft - workers performance when using different formats of engineering information? 	<ul style="list-style-type: none"> • Craft-workers' spatial cognition influence differently in task performance when using different formats of engineering information. • When using different information formats, Demographics (specifically age and work experience) influence differently in task performance. • When using conventional 2D format of information, workers with lower spatial cognition/or experience perform worse in executing an assigned task, compared to workers with higher spatial cognition/or experience.
<p>Paper 3 (Chapter 4)</p>	<ul style="list-style-type: none"> • How do workers' gaze patterns differ depending on the use of different formats of engineering information? • How do spatial cognition affect workers' gaze pattern when using different information formats. 	<ul style="list-style-type: none"> • There are different eye gaze patterns when using different information formats. • The improvement in performance when using different engineering information format is associated to eye gaze patterns. • Differences in gaze patterns are associated with differences in spatial cognition. • When 3D information was provided, individuals with a lower spatial cognition are able to work as efficiently (based on time to completion, rework and errors) than their counterparts with a higher spatial cognition, but they rely greater on 3D information to their work.

To sum up, the dissertation supports five distinct outcomes realized through research efforts:

- 1) *Understanding the relationship between design complexity and engineering information formats in relation to craft workers' performance.*

The results revealed that as the level of design complexity increased the effects of using different engineering information formats increased. While this research was conducted in a controlled setting with scale piping models; if the field trials had been conducted on an actual construction project, engineering information formats would still likely have influenced craft workers' performance because construction sites include more complex tasks.

- 2) *Comparing the effects of using different 3D information formats.*

Realistic 3D physical models provide a visual and tangible perspective that cannot be achieved with 2D drawings or even 3D CAD models. However, based on the results, different types of 3D information led very similar results in task performance based on time to completion, rework, and errors, except the direct and indirect work rates. Craft workers who used the 3D physical model plus the 2D isometric format took a longer time (indirect work rate) looking at the physical model to adjust its orientation in order to be the same as the orientation of the 2D isometric sheets. In contrast, in the 2D isometric plus 3D images format, craft workers were able to coordinate a set of drawings through the plan north arrow that was placed on both the 2D isometric and 3D image CAD sheets.

- 3) *Understanding the interdependency of individual spatial cognition, demographics, information formats, and complex task execution.*

This research takes a significant departure from the theories and understanding of spatial cognitive functions in two ways. First, the research developed a new understanding of the effectiveness of spatial support tools that focus on just-in-time familiarization of individuals subjected to novel

environments. Through the use of eye tracking technology, the dissertation broadened the understanding of how individuals encode integrated information about spatial layouts in working memories as well as how to always increase information retention rate and respond by practicing what is already acquired.

4) Adjusting construction information systems to spatial cognition and demographics

The research findings have depicted a significant understanding of how existing engineering deliverables can be improved to assist craft workers with varying levels of spatial cognition and demographics to improve both their efficiency and their effectiveness in planning and executing construction tasks.

5) Outreach in education and training

The findings indicate that supplementing 2D drawings with 3D information helps to communicate complex spatial topics effectively and efficiently. This makes it possible to integrate the topics of plan reading and task training into training modules for construction craft workers. Curriculums for such programs are already in existence through agencies such as the National Center for Construction Education and Research (NCCER), which is a non-profit organization that develops training curriculums across all construction trades.

5.2 Suggestions for future research

5.2.1 Limitations of Current Datasets

The dissertation relied on developing models of scaled piping works with different information formats to examine how the use of different engineering information formats, worker spatial cognition, and demographics influence the performance in task execution.

The scale of the model assembly task is a limitation of this dissertation. Pipes used on most industrial projects are often 152.4 mm (6 in.) in diameter or larger, which is significantly larger than the 12.7 mm (0.5 in.) PVC pipe used in this study. Although fitting pipe requires more tasks (e.g., welding, material and equipment handling, and bolting), this research model focused only on measuring and assembling pipes through reading and understanding engineering drawings. Also this research focused on three factors that affect worker productivity; information format, spatial cognition and demographics. However, construction sites are dynamic environments with numerous factors affecting craft workers' performance, such as information, equipment, tools, materials, rework, supervision, congestion, safety, weather, sequencing, individual skills of workers, size of components, specification, work content, design features, and work scope. The author readily acknowledge that these and other jobsite factors would likely influence results, if the field trials were conducted on a construction worksite versus being conducted in a controlled setting.

5.2.2 Opportunities for Future Research

Understanding how individual craft workers access, view or interpret the information they need to perform their tasks is a basic gap in the current body of knowledge. Further research is needed to further investigate the improvements due to advanced 3D visualization technologies, such as 3D printers, tablets, augmented reality, and virtual reality. There are several recommendations for additional research, including:

- Examine the influence of training and education on the use of different information formats. How do variations in training and education in the use of different engineering information formats influence task performance.

- Examine the influence of spatial cognition while controlling for the effects of demographics. This would help to understand how the heterogeneity of individual spatial cognitive abilities is influenced by demographics (age, work experience, and previous training).
- Apply this research experimental design to real construction tasks by using alternative information formats in the field assembly of actual field materials instead of scale model sets. This expansion in scope would build upon and improve this work by understanding if the results described herein are conservative, representative, or an over estimation of the results to be experienced in the field.
- Leverage the significant advancements in technology for use in engineering information deliverables, such as 3D CAD, 3D printers, tablets, augmented reality, and virtual reality. Further research could investigate and identify how such 3D information can be presented for field use.
- Utilize eye tracking technology to identify areas of interest in each information format for deeper analysis, such as particular areas of spatial complexity. This could be done through heat maps after aggregating all participants' results. Heat maps serve as an excellent method of visualizing areas of spatial complexity that have a high number of gaze points. In heat maps, red areas indicate the highest concentration of eye fixations and attention, and gradations from yellow to green areas indicate less visual attention. Identifying areas of interest would help to improve complex areas by making them easier to interpret.
- Examine the interaction between demographics and fixation patterns when using different information formats. Eye gaze plots allow identification of the frequency of fixations. Developing aggregated eye gaze plots for groups sorted by demographics will allow further

examination of how individuals with different demographics interface differently with engineering information.

- Identify and understand how eye scan paths differ by group and performance in each information format. A scan path illustrates a whole sequence, including saccade, fixation, and saccade. In the task of searching, an optimal scan path can be viewed as a straight line directed toward the target, with a short duration of fixation on the target. Developing aggregated eye scan paths for groups sorted by demographics and/or spatial cognition will allow for examination of how individuals in different groups interface differently with engineering information. Also, aggregated eye scan paths for different groups will identify which scan paths lead to better performance. Future research can evaluate scan paths from derived measures, including the length and duration of a scan path, whereby a long scan path shows less searching efficiency.
- Measure individuals' cognitive workload based on changes in pupil diameter by using eye tracking glasses that detect a small but reliable increase in pupil diameter during the experiment. This would help to measure the level of task difficulty, identify aspects in tasks that require high workload, and analyze how workload differs between individuals in different groups when using different formats of engineering information delivery.

INTEGRATED REFERENCES

- Azhar, S. (2011). Building Information Modeling (BIM): “Trends, Benefits, Risks and Challenges for the AEC Industry”. *Leadership and Management in Engineering*, 11, pp 241-252, American Society of Civil Engineers.
- Baldwin, C. L. (2009). “Individual differences in navigational strategy: Implications for display design. Theory”. *Issues Ergon. Sci.*, 10(5), 443–458.
- Barr, R.E. & Juricic, D. (1994) “From Drafting to Modern Design Representation: The Evolution of Engineering Design Graphics”, *Journal of Engineering Education*, July 1994, pp 263-270.
- Bhoir, S., Hasanzadeh, S., Esmaili, B., Michael, D., Dodd, and Fardhosseini, M.S. (2014). “Measuring Construction Workers’ attention using Eye tracking Technology.” *Construction Specialty Conference*, (222), 1-6.
- Bowden, S., Dorr, A., Thorpe, A., Anumba, C. (2006). “Mobile ICT Support for Construction Process Improvement”. *Automation in Construction* Vol. 15 (5). 664–676.
- Bruneau, D., Sasse, M. A., & McCarthy, J. D. (2002). “The eyes never lie: The use of eye tracking data in HCI research.” In *Proceedings of the CHI’02 Workshop on Physiological Computing*. NY: ACM Press.
- Dadi, G. B., Goodrum, P. M., Taylor, T. R., & Maloney, W. F. (2014b). “Effectiveness of communication of spatial engineering information through 3D CAD and 3D printed models”. *Visualization in Engineering*, 2(1), 1-12.
- Dadi, G. B., Goodrum, P. M., Taylor, T. R., and Carswell, C. M. (2014a). “Cognitive Workload Demands Using 2D and 3D Spatial Engineering Information Formats”. *Journal of Construction Engineering and Management*, 140(5).
- Dadi, G. B., Taylor, T. R., Goodrum, P. M., & Maloney, W. F. (2014c). “Performance of 3D computers and 3D printed models as a fundamental means for spatial engineering information visualization”. *Canadian Journal of Civil Engineering*, 41(10), 869-877.
- Dai, J., Goodrum, P. M., and Maloney, W. F. (2009a). “Construction Craft Worker’ Perceptions of the Factors Affecting Their Productivity”. *Journal of Construction Engineering and Management*, (135), 217–226.
- Duchowski, A. (2002). “A breadth-first survey of eye-tracking applications.” *Behavior Research Methods, Instruments, & Computers*, 34(4), 455-470. <http://dx.doi.org/10.3758/bf03195475>

- Eastman, C., M. (2008). BIM handbook: "A guide to building information modeling for owners, managers, designers, engineers, and contractors". *Hoboken, New Jersey: Wiley*
- Ekstrom, R. B., French, J. W., Harman, H. H., and Dermen, D. (1976). "Manual for kit of factor-referenced cognitive tests", *Educational Testing Service, Princeton, NJ.*
- Emmitt, S. and Gorse, C. (2003). "Construction Communication". *Blackwell Publishing, Oxford.*
- Encarnaçao, J. L., Lindner, R., Schlechtendahl E. G., (1990) "Computer Aided Design, Fundamentals and System Architectures." *Springer Berlin Heidelberg.*
- Fang, Y., Cho, Y., & Chen, J. (2015). "Analyzing Construction Workers' Recognition of Hazards by Estimating Visual Focus of Attention". *Automation in Construction.*
<http://dx.doi.org/10.1016/j.autcon.2016.08.025>
- Feuerstack, S., Lüdtkke, A., and Osterloh, J. P. (2015). "A tool for easing the cognitive analysis of design prototypes of aircraft cockpit instruments: The human efficiency evaluator." Proc., *European Conf. on Cognitive Ergonomics 2015, ACM, New York, 22.*
- Goldberg, H. J., & Kotval, X. P. (1999). "Computer interface evaluation using eye movements: Methods and constructs" *International Journal of Industrial Ergonomics*, 24, 631-645.
- Goldberg, H. J., & Wichansky, A. M. (2003). "Eye tracking in usability evaluation: A practitioner's guide."
- Goodrum, P. M., and Miller, J. M. (2015). "Innovative delivery methods of information to the crafts. Construction Industry Institute", *Univ. of Texas at Austin, Austin, TX. RT 327.*
- Goodrum, P., Miller, J., Sweany, J., and Alruwaythi, O. (2016). "Influence of the Format of Engineering Information and Spatial Cognition on Craft-Worker Performance". *Journal of Construction Engineering and Management*, Vol. 142, No. 9.
- Gouett, M., Haas, C., Goodrum, P., and Caldas, C. (2011). "Activity analysis for direct-work rate improvement in construction". ASCE. *Journal of Construction Engineering and Management*, 37: 1117-1124.
- Hasanzadeh, S., Esmaili, B., and Dodd, M (2016). "Measuring Construction Workers' Real-Time Situation Awareness Using Mobile Eye-Tracking". *Construction Research Congress*, 8(8), 621.
- Hegarty, M., Richardson, A. E., Montello, D. R., Lovelace, K., & Subbiah, I. (2002). "Development of a self-report measure of environmental spatial ability". *Intelligence*, 30, 425-447.

- Holmqvist, K. (2011). "Eye tracking: A comprehensive guide to methods and measures". Oxford: Oxford University Press.
- Just, M. A., & Carpenter, P. A. (1976). "Eye fixations and cognitive processes". *Cognitive Psychology*, 8, 441-480.
- Liberda, M., Ruwanpura, J., & Jergeas, G. (2003). "Construction Productivity Improvement: A Study of Human, Management and External Issues". ASCE. *Construction Research Congress*. 1-8. 10.1061/40671(2003)5
- Lohman, D. F. (1979). "Spatial ability: A review and reanalysis of the correlational literature". Rep. No. ADA075972, U.S. Office of Naval Research, Arlington, VA.
- Mahoney, J. and Tatum, C. B. (1994). "Construction Site Application of CAD". *Journal of Construction Engineering and Management*, 120, pp 617-631.
- Marshall, S. (2000). "Method and apparatus for eye tracking and monitoring pupil dilation to evaluate cognitive activity". U.S. Patent 6,090,051, July 2000.
- Naoum, S. G., (2016). "Factors influencing labor productivity on construction sites: A state of the art literature review and a survey". *International Journal of Productivity and Performance Management*. ISSN: 1741-0401
- Neumann, U., and Majoros, A. (1998). "Cognitive, performance, and systems issues for augmented reality applications in manufacturing and maintenance". Proc., *Virtual Reality Annual Int. Symp.*, IEEE, Washington, DC, 4-11.
- O'Brien, W. J., Hurley, M. J., Mondragon Solis, F. A., and Nguyen, T. (2011). "Cognitive task analysis of superintendent's work: A case study and critique of supporting information technologies". *J. Inform. Technol. Constr.*, 16(2011), 529-566.
- O'Connor, J. T. (1985). "Impacts of Constructability Improvement". ASCE. *Journal of Construction Engineering and Management*, (111) 404-410.
- Ogelsby, C. H., Parker, H. W., and Howell, G. A. (1989). "Productivity improvement in construction." *McGraw-Hill*, New York.
- Poole, A., & Ball, L. (2005). "Eye Tracking in Human-Computer Interaction and Usability Research: Current Status and Future Prospects". Retrieve from: <http://citeseer.ist.psu.edu/viewdoc/download?doi=10.1.1.95.5691&rep=rep1&type=pdf>
- Poole, A., & Ball, L. (2007). "The Current Status of Computer-Assisted Telephone Interviewing: Recent Progress and Future Prospects". *Psychological Methods & Research*, 12(2), 119-142.

- Pradhananga, N., Jianu, R., & Orabi, W. (2016). "Eye-tracking Technology for Construction Safety: A feasibility Study". *AMR*, 952, 347-350.
<http://dx.doi.org/10.4028/www.scientific.net/amr.952.347>
- Quarles, J., Lamportang, S., Fischler, I., Fishwick, P., & Lok, B. (2008). "Tangible user interfaces compensate for low spatial cognition. In 3D User Interfaces", 2008. 3DUI 2008. IEEE *Symposium on* (pp. 11–18).
- Rayner, K., & Pollatsek, A. (1989). "The psychology of reading". Englewood Cliffs, NJ: Prentice Hall.
- Robert, J. K., Jacob, D., & Karn, S. (2013). "Eye Tracking in Human–Computer Interaction and Usability Research: Ready to Deliver the Promises". *International Journal of Human-Computer Interaction*, (4), 574-597.
- Sharps, M., Price, J., and Williams, J. (1994). "Spatial cognition and gender: Instructional and stimulus influences on mental image rotation performance". *Psychol. Women Q.*, 18(3), 413–425
- Shen, L, Chua, D.K.H., (2011). "Application of Building Information Modelling (BIM) and Information Technology (IT) for Project Collaboration". EPPM, *Singapore*, 20-21 Sep 2011
- Stanney, K. M., and Salvendy, G. (1995). "Information visualization; assisting low spatial individuals with information access tasks through the use of visual mediators." *Ergonomics*, 38(6), 1184–1198.
- Stiles, J., Kritchevsky, M., Bellugi, U. (1988), "Spatial Cognition: Brain Bases and Development." *Psychology Press*.
- Sweany, J., Goodrum, P., Miller, J. (2016). "Analysis of empirical data on the effects of the format of engineering deliverables on craft performance". *Automation in Construction*, Volume 69. (2016) 59-67
- Taylor, H., Thomas, A., Artuso, C., and Eastman, C. (2014). "Effects of global and local processing on visuospatial working memory". *Spatial Cognition IX: Int. Conf.*, Bremen, *Springer*, Switzerland, 14–75.
- The US National Building Information Model Standard Project Committee, Frequently Asked Questions about the National BIM Standard-United States, <https://www.nationalbimstandard.org/faqs#faq1>, (August. 22, 2016).
- Thomas, R., and Sakarcan, A. S. (1994). "Forecasting labor productivity using factor model". *Journal of Construction Engineering and Management*. 10.1061/ (ASCE) 0733 9364(1994)120:1(228), 228–239.

- Vecchi, T., Bottini, G. (2006). "Imagery and Spatial Cognition: Methods, models and cognitive assessment." *John Benjamins Publishing*.
- Wood, R. E. (1986). "Task complexity: Definition of the construct." *Organizational Behavior and Human Decision Processes*, 37: 60–82.
- Wynne, A. (2012). "CAD - The Greatest Advancement in Construction History". Retrieved from The Architect's Journal: <https://www.architectsjournal.co.uk/cad-the-greatest-advance-in-construction-history/1996442.article>
- Yousefi, H., Karan, E., Mohammadpour, A., & Asadi, S. (2015). "Implementing Eye Tracking Technology in the Construction Process". *Associated Schools of Construction*, 2(1), 48. <http://dx.doi.org/10.4103/2277-9183.122445>

APPENDIX

1. The three information formats for the **simple design**

a. 2D Isometric Drawing (traditional method)

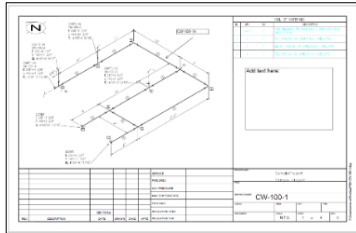

Spool 1

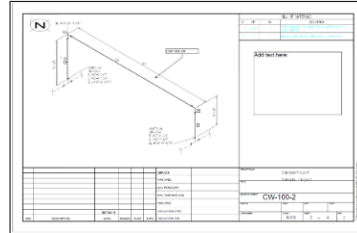

Spool 2

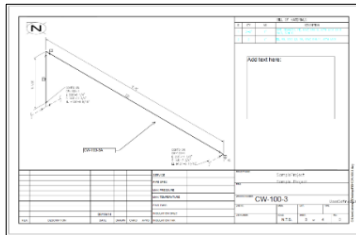

Spool 3

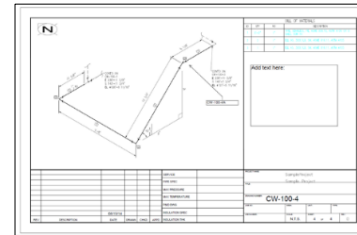

Spool 4

b. 2D Isometric Drawing plus 3D image

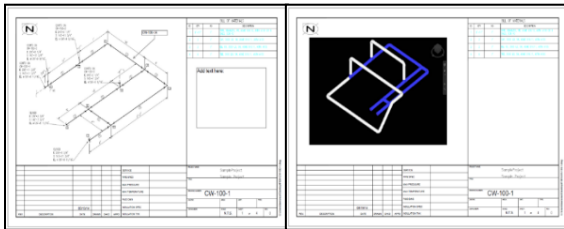

Spool 1

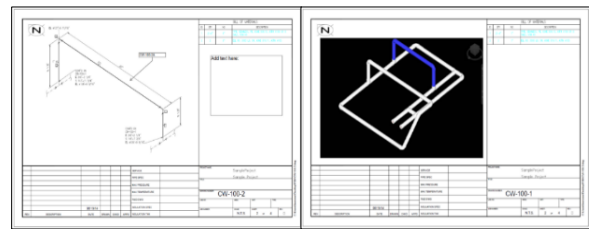

Spool 2

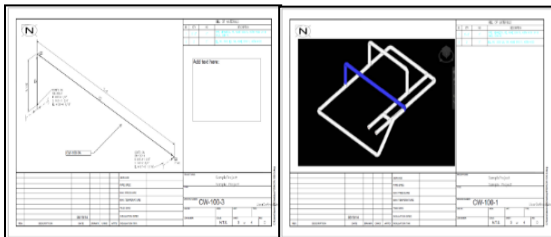

Spool 3

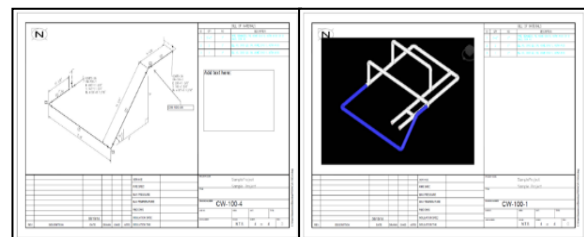

Spool 4

c. 2D Isometric Drawing plus 3D Physical Model

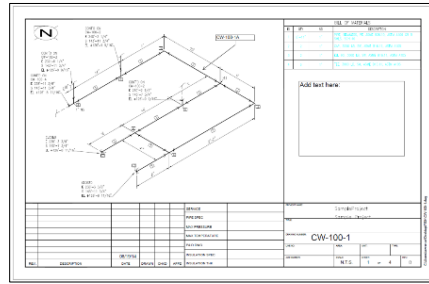

Spool 1

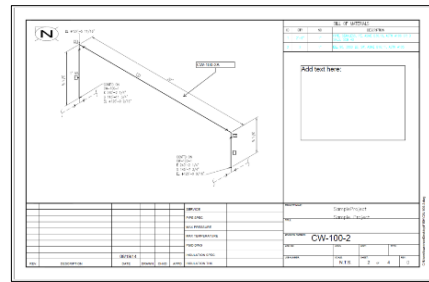

Spool 2

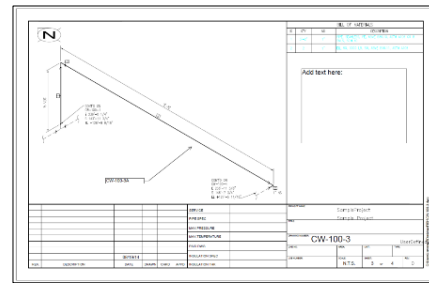

Spool 3

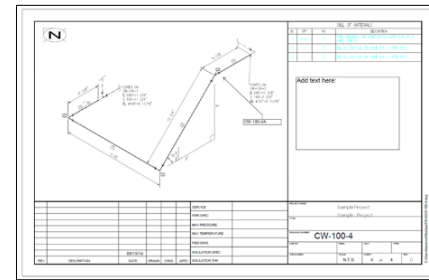

Spool 4

+

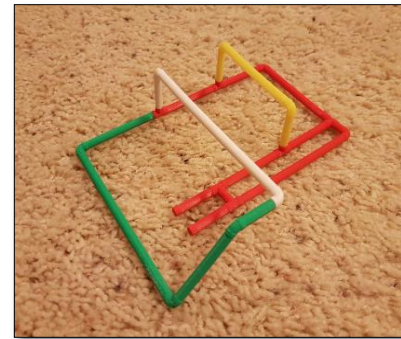

2. The three information formats for the **medium design**

a. 2D Isometric Drawing (traditional method)

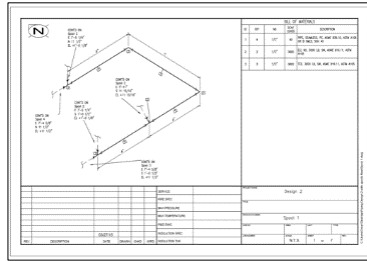

Spool 1

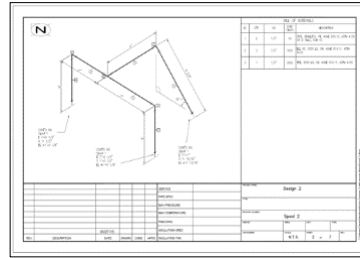

Spool 2

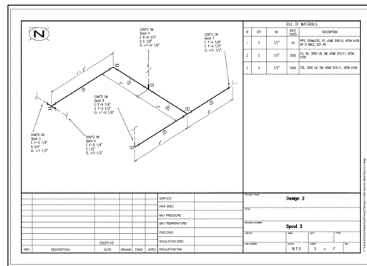

Spool 3

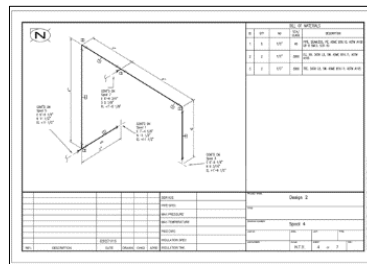

Spool 4

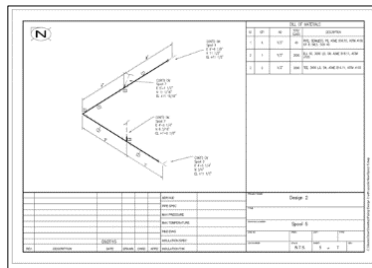

Spool 5

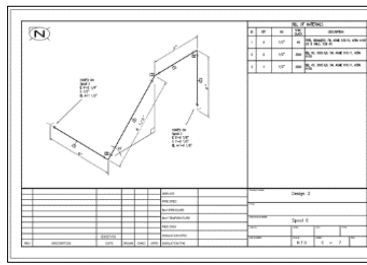

Spool 6

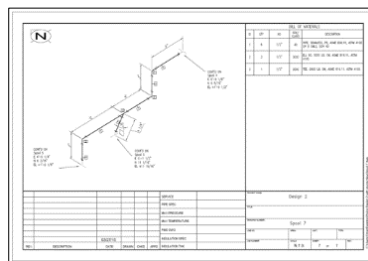

Spool 7

b. 2D Isometric Drawing plus 3D image

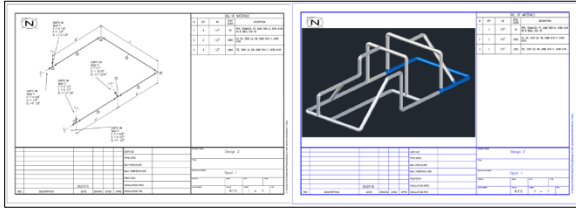

Spool 1

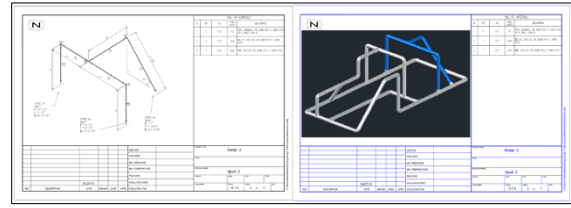

Spool 2

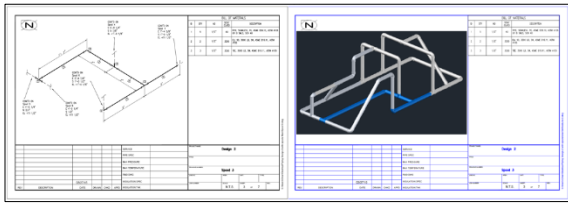

Spool 3

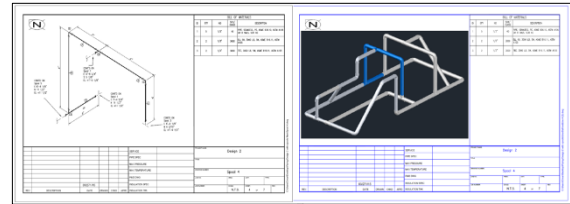

Spool 4

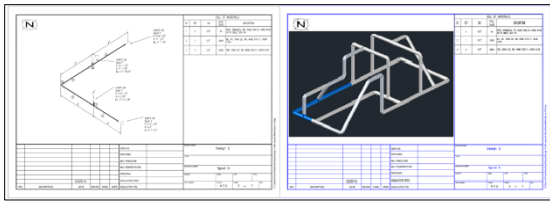

Spool 5

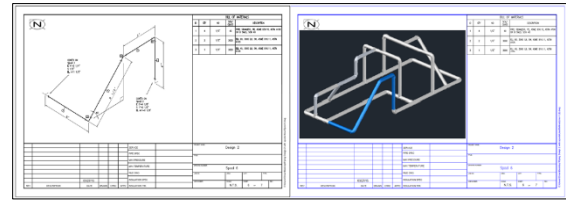

Spool 6

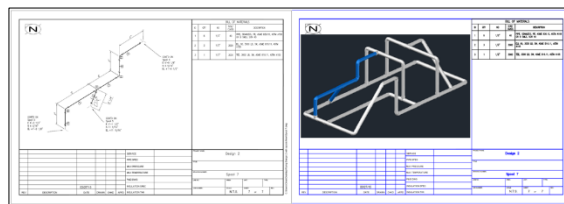

Spool 7

c. 2D Isometric Drawing plus 3D Physical Model

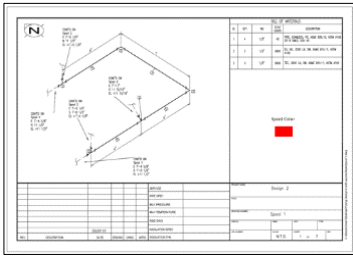

Spool 1

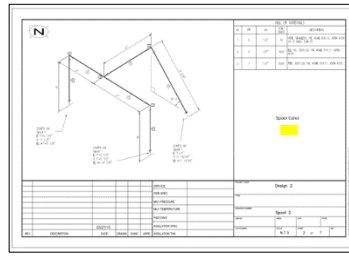

Spool 2

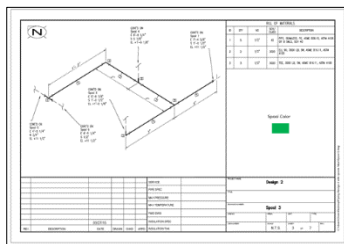

Spool 3

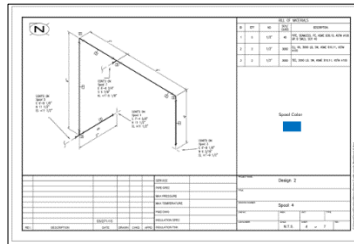

Spool 4

+

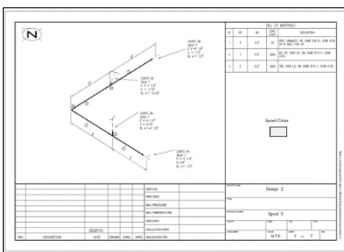
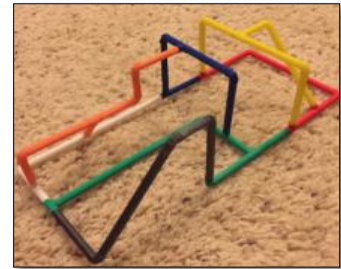

Spool 5

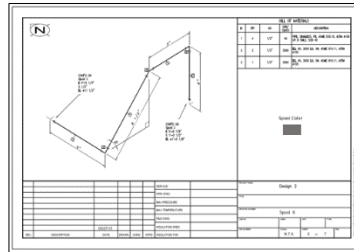

Spool 6

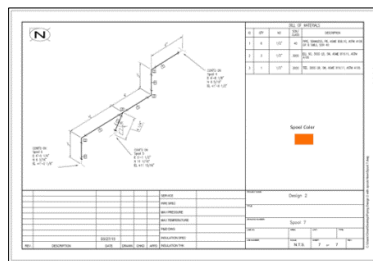

Spool 7

3. The three information formats for the **complex design**

a. 2D Isometric Drawing (traditional method)

Spool 1

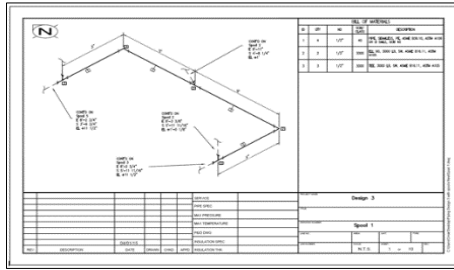

Spool 2

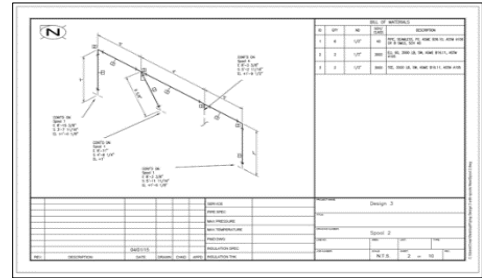

Spool 3

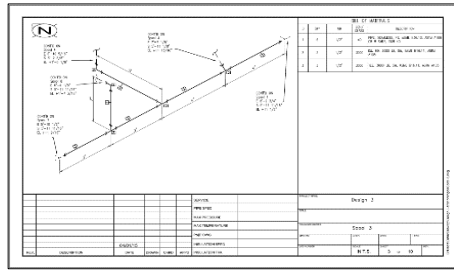

Spool 4

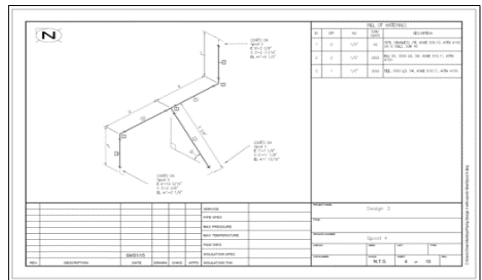

Spool 5

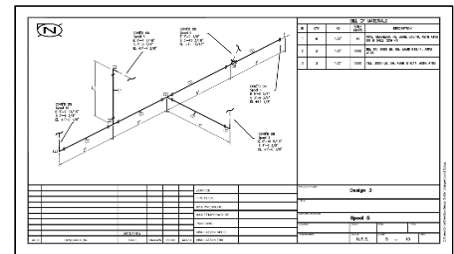

Spool 6

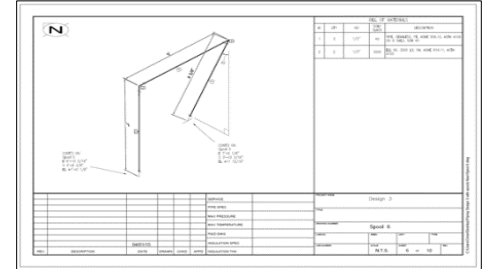

Spool 7

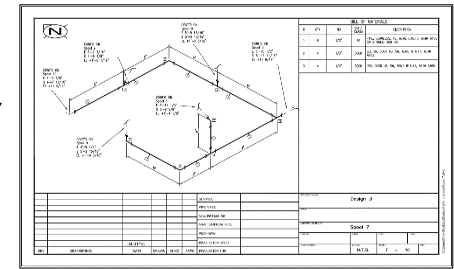

Spool 8

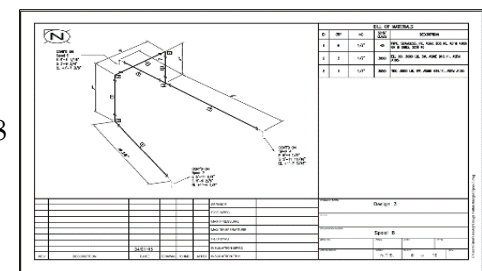

Spool 9

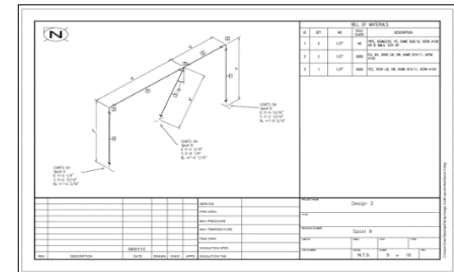

Spool 10

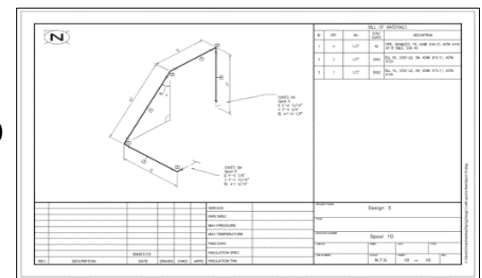

b. 2D Isometric Drawing plus 3D image

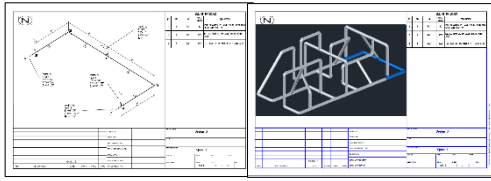

Spool 1

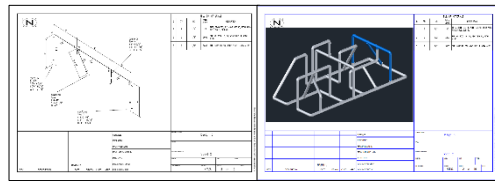

Spool 2

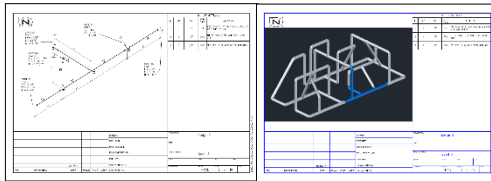

Spool 3

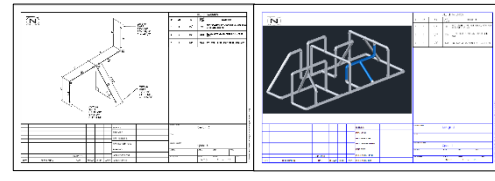

Spool 4

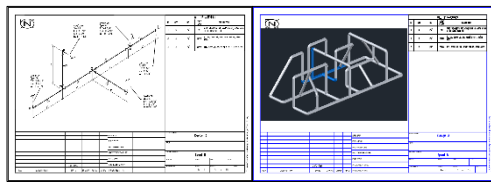

Spool 5

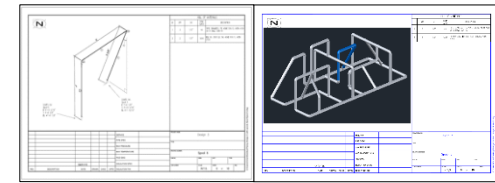

Spool 6

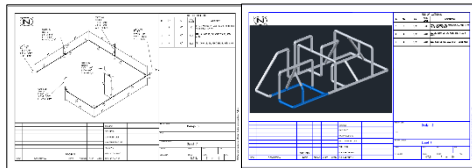

Spool 7

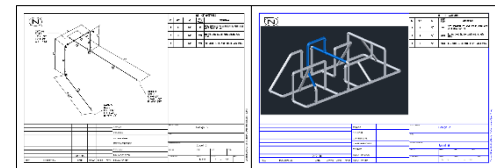

Spool 8

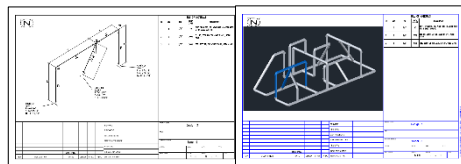

Spool 9

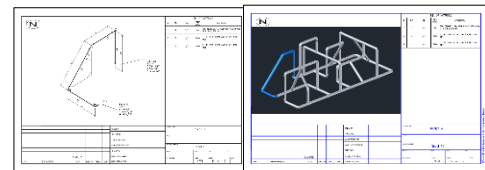

Spool 10

c. 2D Isometric Drawing plus 3D Physical Model

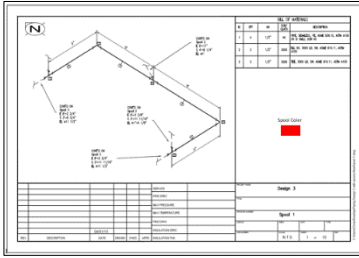

Spool 1

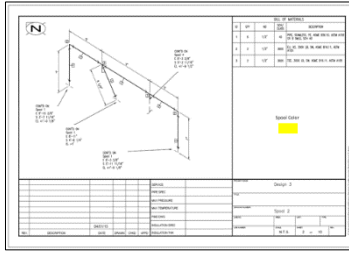

Spool 2

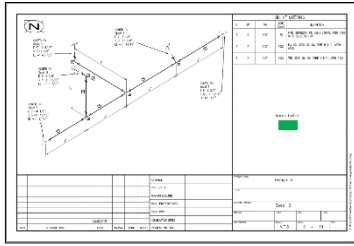

Spool 3

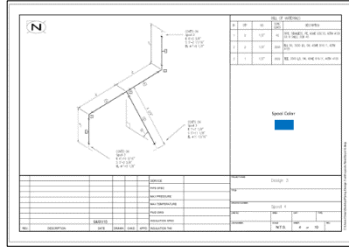

Spool 4

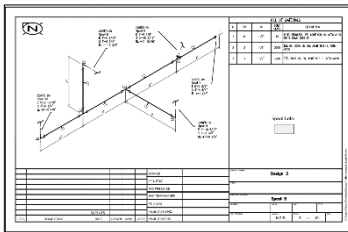

Spool 5

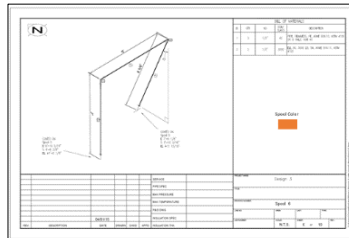

Spool 6

+

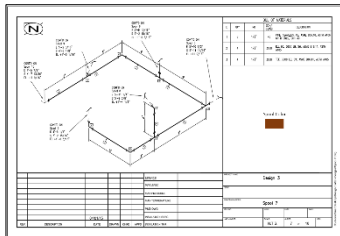

Spool 7

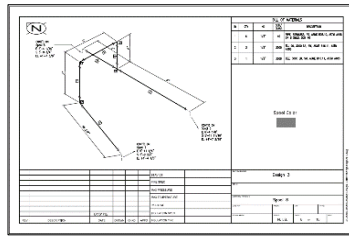

Spool 8

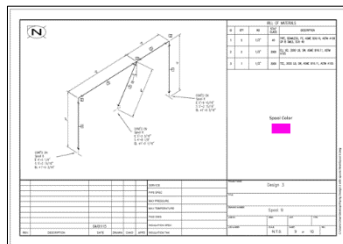

Spool 9

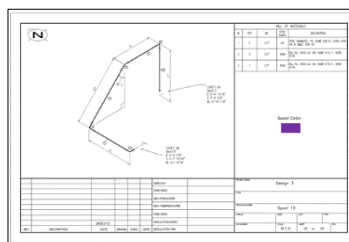

Spool 10

4. Demographic Questionnaire

I understand that my responses to this questionnaire are voluntary and that I can choose not to answer certain questions. Furthermore, I understand that I will not be identified by name in any research or publications resulting from this study.

Demographic Information

Age: _____

Gender: _____

Education Background

Total years of education (e.g. kindergarten through high school = 13 years): _____

Years of apprenticeship training _____

Years of Journeyman training _____

Please select your highest level of education:

- Less than a high school diploma
- High school diploma
- Some college, no degree
- Associate's degree
- Bachelor's degree
- Master's degree
- Professional degree
- Doctoral degree

Have you had any formal training in engineering drawings/blueprint reading (yes/no): _____

Work Experience

Current Occupation: _____

Type of Construction or Engineering Industry Work Experience (design, construction, co-op, project engineer, worker, pipefitter, etc....): _____

Total Years of Work Experience in the field of Construction or Engineering Industry: _____

Card Rotation Test (1.5 minutes)

S = same (only rotated)

D = different (flipped and/or rotated)

	S <input type="checkbox"/> D <input checked="" type="checkbox"/>	S <input checked="" type="checkbox"/> D <input type="checkbox"/>	S <input checked="" type="checkbox"/> D <input type="checkbox"/>	S <input type="checkbox"/> D <input checked="" type="checkbox"/>	S <input type="checkbox"/> D <input checked="" type="checkbox"/>	S <input checked="" type="checkbox"/> D <input type="checkbox"/>	S <input type="checkbox"/> D <input checked="" type="checkbox"/>	S <input checked="" type="checkbox"/> D <input type="checkbox"/>
	S <input checked="" type="checkbox"/> D <input type="checkbox"/>	S <input checked="" type="checkbox"/> D <input type="checkbox"/>	S <input checked="" type="checkbox"/> D <input type="checkbox"/>	S <input type="checkbox"/> D <input checked="" type="checkbox"/>	S <input checked="" type="checkbox"/> D <input type="checkbox"/>	S <input checked="" type="checkbox"/> D <input type="checkbox"/>	S <input checked="" type="checkbox"/> D <input type="checkbox"/>	S <input checked="" type="checkbox"/> D <input type="checkbox"/>
	S <input checked="" type="checkbox"/> D <input type="checkbox"/>	S <input type="checkbox"/> D <input checked="" type="checkbox"/>	S <input type="checkbox"/> D <input checked="" type="checkbox"/>	S <input type="checkbox"/> D <input checked="" type="checkbox"/>	S <input checked="" type="checkbox"/> D <input type="checkbox"/>	S <input checked="" type="checkbox"/> D <input type="checkbox"/>	S <input checked="" type="checkbox"/> D <input type="checkbox"/>	S <input type="checkbox"/> D <input checked="" type="checkbox"/>
	S <input checked="" type="checkbox"/> D <input type="checkbox"/>	S <input checked="" type="checkbox"/> D <input type="checkbox"/>	S <input type="checkbox"/> D <input checked="" type="checkbox"/>	S <input checked="" type="checkbox"/> D <input type="checkbox"/>	S <input type="checkbox"/> D <input checked="" type="checkbox"/>	S <input type="checkbox"/> D <input checked="" type="checkbox"/>	S <input type="checkbox"/> D <input checked="" type="checkbox"/>	S <input checked="" type="checkbox"/> D <input type="checkbox"/>
	S <input type="checkbox"/> D <input checked="" type="checkbox"/>	S <input checked="" type="checkbox"/> D <input type="checkbox"/>	S <input type="checkbox"/> D <input checked="" type="checkbox"/>	S <input type="checkbox"/> D <input checked="" type="checkbox"/>	S <input checked="" type="checkbox"/> D <input type="checkbox"/>	S <input checked="" type="checkbox"/> D <input type="checkbox"/>	S <input type="checkbox"/> D <input checked="" type="checkbox"/>	S <input checked="" type="checkbox"/> D <input type="checkbox"/>

_____ - _____ = _____ / 40

Correct Answers – Incorrect Answers = Total Score

6. Cube Comparison Test Answers

Cube Comparisons

Wooden blocks such as children play with are often cubical with a different letter, number, or symbol on each of the six faces (top, bottom, four sides). Each problem in this test consists of a drawing of pairs of cubes or blocks of this kind. Remember, there is a different design, number, or letter on each face of a given cube or block. Compare the two cubes in each pair below.

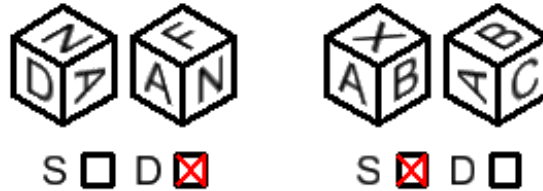

The first pair is marked D because they must be drawings of **different** cubes. If the left cube is turned so that the A is upright and facing you, the N would be to the left of the A and hidden, not to the right of the A as is shown on the right hand member of the pair. Thus, the drawings must be of different cubes.

The second pair is marked S because they could be drawings of the **same** cube. That is, if the A is turned on its side the X becomes hidden, the B is not on top, and the C (which was hidden) now appears. Thus the two drawings could be of the same cube.

Note: No letters appear on more than one face of a given cube. Except for that, any letter can be on the hidden faces of a cube.

Work the three examples below.



The first pair immediately above should be marked D because the X cannot be at the peak of the A on the left hand drawing and at the base of the A on the right hand drawing. The second pair is “different” because P has its side next to G on the left hand cube but its top next to G on the right hand cube. The blocks in the third pair are the same, the J and K are just turned on their side, moving the O to the top. Your score on this test will be the number marked correctly minus the number marked incorrectly. Therefore, it will **not** be to your advantage to guess unless you have some idea which choice is correct. Work as quickly as you can without sacrificing accuracy.

You will have **2 minutes** for this test. When you have finished this test, STOP.

Cube Comparison Test (2 minutes)

S = same (same cube)

D = different (different cubes)



S D



S D



S D



S D



S D



S D



S D



S D



S D



S D



S D



S D



S D



S D

_____ - _____ = _____ / 14

Correct Answers – Incorrect Answers = Total Score

7. Blank Analysis Sheet

Date	PIN		Time	Direct Work	Indirect Work	Rework
			0:30	X		
			1:00	X		
			1:30			X
Units			2:00	X		
Direct			2:30		X	
Indirect			3:00			
Rework			3:30			
			4:00			
			4:30			
Percentage			5:00			
Units			5:30			
Direct			6:00			
Indirect			6:30			
Rework			7:00			
			7:30			
			8:00			
Info Type:			8:30			
			9:00			
# Errors:			9:30			
			10:00			
# Uninstalled:			10:30			
			11:00			
% Complete:			11:30			
			12:00			
Card Rotation:			12:30			
			13:00			
Cube Comparison:			13:30			
			14:00			
			14:30			
Total Time:			15:00			
			15:30			
			16:00			
			Total			

8. IRB Approval



Institutional Review Board
563 UCB
Boulder, CO 80309
Phone: 303.735.3702
Fax: 303.735.5185
FWA: 00003492

APPROVAL

17-Mar-2016

Dear Omar Alruwaythi,

On 17-Mar-2016 the IRB reviewed the following protocol:

Type of Submission:	Initial Application
Review Category:	Expedited - Category 6,7
Title:	The Influence of the Format of Engineering Information, Spatial Cognition, and Demographics on Craft-Worker Performance.
Investigator:	Alruwaythi, Omar
Protocol #:	16-0165
Funding:	None
Documents Approved:	16-0165 Consent Form (17Mar16); Data Collection Example.xlsx; Demographics Questionnaire & Post Questionnaire.docx; 16-0165 Protocol (17Mar16); Industry Professionals and Contractors Recruitment Email.docx; The Research Flyer;
Documents Reviewed:	HRP-211: FORM - Initial Application;
Notes:	- All investigators conducting research activities at the University of Colorado, regardless of affiliation (Faculty, Staff or Student of any level), must complete an annual DEPA submission to manage any possible conflicts of interest or document that no conflicts exist. Please complete the DEPA/COI Process prior to initiating this study.

The IRB approved the protocol from 17-Mar-2016 to 16-Mar-2017 inclusive.

Before 14-Feb-2017, you are to submit a completed [FORM: Continuing Review \(HRP-212\)](#) and required attachments to request continuing approval or closure. This protocol will expire if continuing review approval is not granted before 16-Mar-2017.

Click the link to find the approved documents for this protocol: [Approved Documents](#). Use copies of these documents to conduct your research. In conducting this protocol you must follow the requirements listed in the [INVESTIGATOR MANUAL \(HRP-103\)](#).