

Tonic glucocorticoids suppress stress-induced MKP-1 gene expression within parvocellular  
neurons

Vanessa Thompson  
Molecular, Cellular, and Developmental Biology  
March 31, 2011

Committee:  
Dr. Kevin Jones  
Dr. Robert Poyton  
Dr. Robert Spencer

## Abstract

Mitogen-activated kinase phosphatase-1 (MKP-1) inhibits the activity of extracellular signaling regulated kinase (ERK-1/2) via dephosphorylation. ERK-1/2 has been shown to be important for membrane excitability that results in corticotropin releasing hormone (CRH) peptide secretion and has been shown to regulate CRH gene transcription. Glucocorticoid hormones produce negative feedback by suppressing both CRH secretion and CRH gene transcription, although the specific molecular mechanism is unknown. In some peripheral tissue cell types, glucocorticoids induce MKP-1 gene transcription; therefore, MKP-1 could be a target gene that contributes to some of glucocorticoid negative feedback actions. We examined whether acute stress (restraint) and tonic glucocorticoids affect MKP-1 gene transcription within the hypothalamic paraventricular nucleus (PVN) and anterior pituitary elements of the hypothalamic-pituitary-adrenal (HPA) axis and in select brain regions (prelimbic and infralimbic cortex) that provide neural input to the HPA-axis. Rats were exposed to no stress or 30 min restraint stress (RS) and were left either adrenal intact or were adrenalectomized, and MKP-1 mRNA was then measured using in situ hybridization. We found that restraint induced MKP-1 gene expression within all the brain regions examined (PVN, prelimbic cortex, and infralimbic cortex) and the pituitary. Adrenalectomy also induced MKP-1 gene expression within all the regions we examined except the prelimbic cortex. Lastly, we also found that adrenalectomy augmented stress-induced MKP-1 expression within the pituitary. These results indicate that MKP-1 gene transcription is upregulated by stress-induced activation of intracellular signal transduction pathways in the brain and pituitary. However, contrary to the previous findings in some peripheral tissues, tonic glucocorticoids suppress rather than induce stress-induced MKP-1 gene expression within the PVN.

## Table of Contents

Background.....	4
HPA axis response to stress.....	4
Clinical relevance of stress.....	4
Glucocorticoids inhibit HPA axis activity.....	5
ERK-1/2 may be a mediator of glucocorticoid negative feedback effects.....	9
MKP-1 regulates ERK-1/2 activity.....	11
Preliminary Studies.....	12
Methods.....	15
Animals.....	15
Surgery.....	15
Experimental Design.....	16
ACTH radioimmunoassay.....	16
In Situ Hybridization (ISH).....	16
Statistical Analysis.....	18
Results.....	19
Discussion.....	22
References.....	27

## I. Background

### *HPA axis response to stress*

The hypothalamic-pituitary-adrenal (HPA) axis consists of three anatomical components. The first component is the paraventricular nucleus (PVN), which is situated within the hypothalamus of the brain. During a psychological or physical stress response, parvocellular neurons within the PVN release corticotropin-releasing hormone (CRH) into portal vessels. CRH then stimulates specialized endocrine cells (corticotrophs) in the anterior pituitary gland to release adrenocorticotrophic hormone (ACTH). ACTH in turn stimulates the adrenal gland to synthesize and secrete glucocorticoids. Glucocorticoids then via a process referred to as negative feedback inhibit further production of CRH, ACTH, and thus more glucocorticoids (30).

### *Clinical relevance of stress*

Although glucocorticoids can be beneficial in a short term response to stress, chronic exposure to glucocorticoids have negative effects on the body that can contribute to illness. Unrestrained psychological stress is associated with hypertension, atherosclerosis, insulin resistance, abdominal fat accumulation, and asthma (11, 13, 19, 32). Moreover, psychological stress especially affects psychological disorders like depression and post-traumatic stress syndrome (PTSD) by either exacerbating the disorder or directly causing it. When HPA axis activity becomes dysregulated, the adrenal gland has an abnormal glucocorticoid secretion pattern, which can then contribute to the pathology of a disease (3). For instance, too much cortisol secretion and impaired glucocorticoid negative feedback has been linked to depressive episodes (1, 23). In contrast, too little cortisol secretion and enhanced negative feedback is associated with PTSD (3). Since HPA axis dysregulation affects so many prevalent diseases, it is crucial to understand glucocorticoid negative feedback mechanisms.

*Glucocorticoids inhibit HPA axis activity*

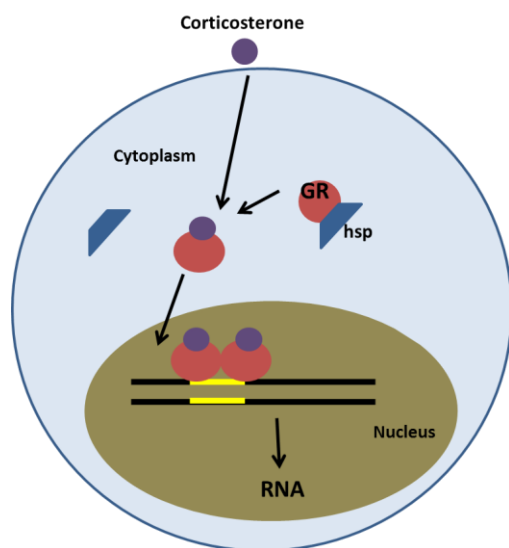

**Figure 1: Glucocorticoids bind to GR, assemble into homodimers and translocate to the nucleus where they can activate gene transcription.**

Glucocorticoids are a subclass of corticosteroid hormones that have important immunological and metabolic functions. Glucocorticoids suppress inflammation and contribute to the regulation of carbohydrate, protein, and fat metabolism. More importantly, glucocorticoids (cortisol in humans and corticosterone in rats) are involved in the physiological and physical response to stress (27). Corticosterone (CORT) binds to two closely related receptors, the mineralocorticoid receptor (MR) than the GR. CORT

binds with higher affinity to MR than the glucocorticoid receptor (GR). As a result, GR is significantly bound only when circulating CORT concentrations greatly increase such as during an acute stress response (23, 24, 29). Both receptors are intracellular and act as hormone-dependent transcription factors (Figure 1). When ligand is not present, GR resides in the cytosol and MR resides both in the cytosol and nucleus (2). Both form a multi-protein complex until binding of ligand causes GR and MR to dissociate from the complex (activated) and translocate to the nucleus (36). Activated GR and MR then assemble into homodimers or heterodimers and bind to a glucocorticoid response element near certain target genes and thus promote or inhibit gene transcription (6). In addition to directly altering gene transcription, GR and MR can associate with other transcription factors (e.g. fos or CREB) or transcription factor ligands (e.g.

CREB binding protein) to regulate gene transcription (18). By modulating gene transcription, glucocorticoids can alter the pattern of gene expression within a parvocellular neuron or a corticotroph and thereby inhibit stress-induced HPA axis activity.

Glucocorticoids can directly and/or indirectly mediate negative feedback effects of the

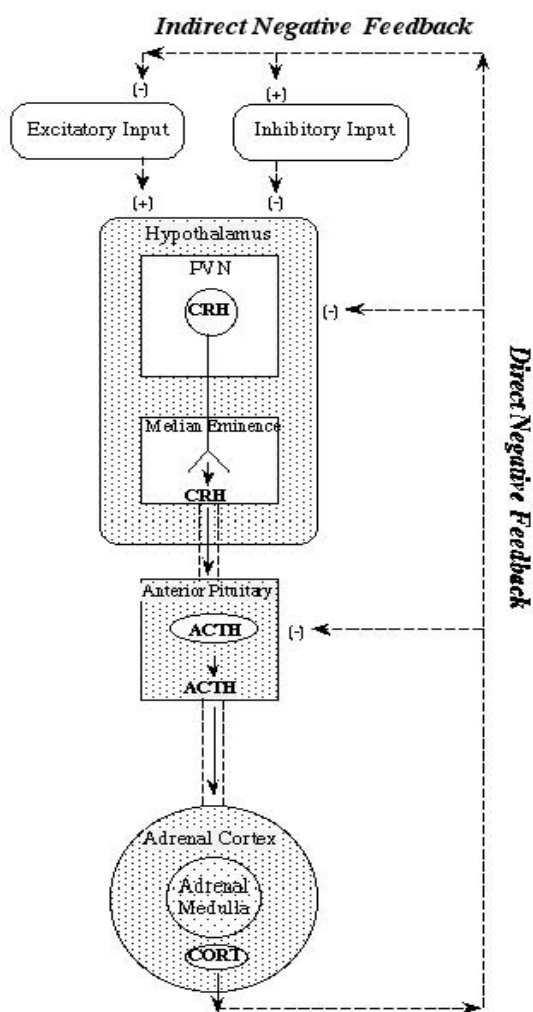

**Figure 2: Corticosterone can act directly on CRH neurons or corticotrophs and indirectly on brain regions outside of the PVN to induce glucocorticoid negative feedback effects.**

HPA axis (Figure 2). When CORT reaches the PVN, it binds to the glucocorticoid receptor (GR) within parvocellular neurons and inhibits further production of CRH, ACTH, and, as a result, glucocorticoids. Likewise, glucocorticoids bind to GR and MR in corticotrophs within the anterior pituitary and inhibit ACTH secretion, thereby preventing glucocorticoid secretion from the adrenal glands (30). However, glucocorticoids can also act indirectly to affect HPA axis activity (Figure 2). For instance, glucocorticoids can act on the ventral hippocampus, a brain region involved in memory and learning, to affect HPA axis activity. The ventral hippocampus sends projections to the bed nucleus of the stria terminalis (BNST), which then projects to the PVN, thereby allowing glucocorticoids to affect CRH secretion (30). Likewise, the medial prefrontal cortex (mPFC) can also facilitate negative feedback effects on stress-induced

HPA axis activity via projections to the BNST (34).

Several factors affect CRH secretion from the PVN and CORT can influence any one of these factors (Figure 3). Parvocellular neurons do not sense stress; instead bisynaptic projections from the medial prefrontal cortex or hippocampus, for example, release neurotransmitters that provide signals to CRH neurons that effectively activate these neurons in response to a stressful event. Binding of these neurotransmitters to their receptors then causes activation of intracellular signal transduction pathways. The immediate effect of intracellular signal transduction pathway activation is the exocytosis of CRH peptide from vesicles at the axon terminal. However, activation of signal transduction pathways can also induce transcription of the CRH gene to replenish depleted prepackaged CRH peptides at the axon terminal. Signal transduction pathway activity also leads to transcriptional activation of other genes, like *mkp-1* or *c-fos*, which may mediate cellular adaptation to chronic stress (33). CORT could produce negative feedback effects by altering activity of the neural input to the PVN or interfering with signal transduction pathways that thereby affects membrane excitability, neurohormone synthesis, and the cell's pattern of gene expression.

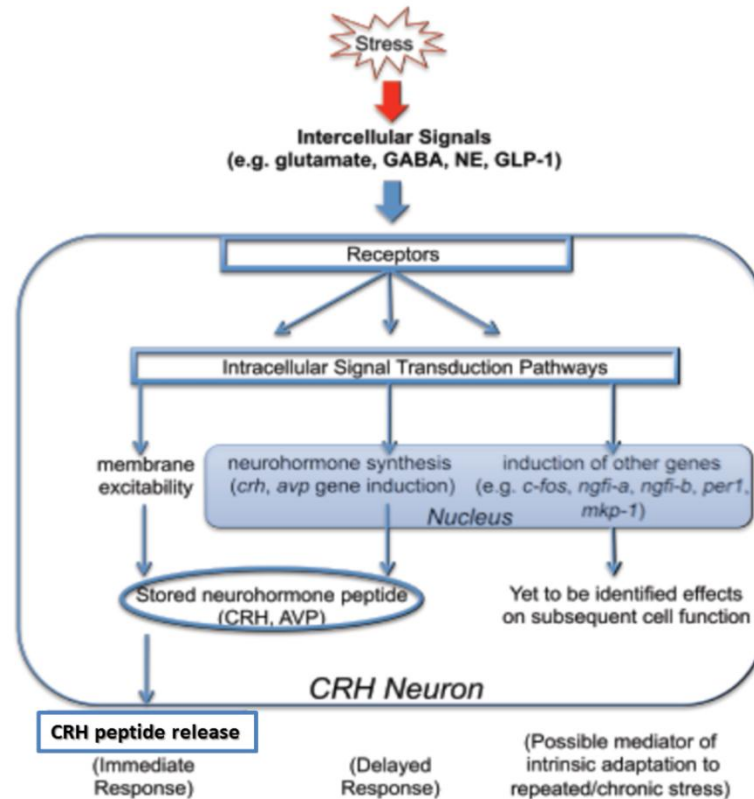

Figure 3: CRH secretion from CRH neurons can be affected by neurotransmitters, receptors, and second messenger pathways. Corticosterone negative feedback actions could target any one of these levels. Adapted from Watts (33).

CORT also has permissive and reactive negative feedback effects on cellular function. During the day, a rat experiences a specific pattern of CORT secretion. In the morning, secreted CORT levels are very low until half way through the rat's inactive period at which point

#### Idealized Corticosterone Secretion Pattern in the Rat

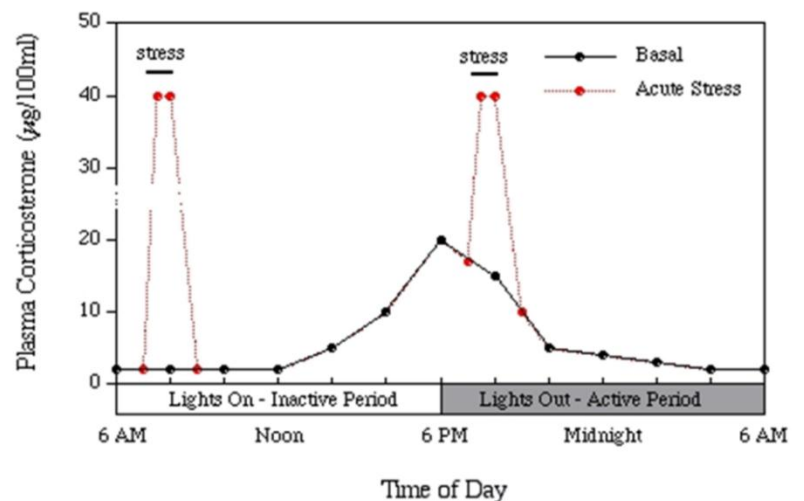

Figure 4: CORT secretion pattern throughout the day for rats.

CORT secretion begins to increase. CORT secretion peaks at the beginning of the active period and then begins declining back to basal



levels (Figure 4). This pattern of secretion represents tonic basal CORT secretion. The tonic presence of CORT has “permissive” actions on cellular function, especially within the PVN or pituitary (26). When tonic CORT is removed by adrenalectomy, basal and stimulated activity of CRH neurons and corticotrophs is upregulated (3). On the other hand, acute stress causes a short-lived, phasic increase in CORT secretion (Figure 4). Phasic CORT has many “reactive” effects on various physiological systems that protect the body from the acute effects of stressors (20). However, the scope to which reactive effects function through different mechanisms from permissive effects of CORT remains unclear.

*ERK-1/2 may be a mediator of glucocorticoid negative feedback effects*

Extracellular signal regulated kinase 1/2 (ERK-1/2) is an intracellular signaling molecule that may play a role in glucocorticoid negative feedback effects. Once ERK-1/2 is phosphorylated (pERK) on a threonine and tyrosine residue, it becomes active and can then phosphorylate other proteins within the cell. For instance, pERK directly activates transcription factors like c-fos (11). pERK also indirectly activates the transcription factor cAMP response element binding protein (CREB) (10), which is the primary transcription factor for the crh gene (35). Thus, pERK could be a mediator for stress-induced crh gene expression within the PVN. In addition, pERK also helps maintain neuronal excitability and therefore could contribute to the membrane excitability that causes exocytosis of CRH (7, 9). Therefore, if tonic or phasic CORT can alter pERK activity within CRH neurons, then corticosterone could directly modify CRH neuron function.

Our lab has shown that restraint stress, a psychological stressor, increases pERK in the PVN within five minutes. We also find, using a double labeled immunohistochemistry procedure, that much of the stress-induced pERK within the PVN is colocalized within CRH

neurons (Figure 5). These results are important because they indicate that pERK is an intracellular signaling molecule that is activated within CRH neurons in response to stress-induced changes in neurotransmitter input to those neurons. Therefore, regulation of pERK levels within CRH neurons could be a direct or indirect target for CORT negative feedback actions. In support of that prospect, the removal of tonic CORT by adrenalectomy augments stimulated levels of pERK within the PVN (Figure 6). Adrenalectomy also causes increases plasma ACTH levels in basal and stimulated states. However, when adrenalectomized rats are given corticosterone replacement in their drinking water, pERK and ACTH levels are normalized back to levels of adrenal intact (Sham) rats (Figure 7). Therefore, CORT, rather than other hormones secreted by the adrenal gland, tonically constrains stress-induced pERK levels within the PVN.

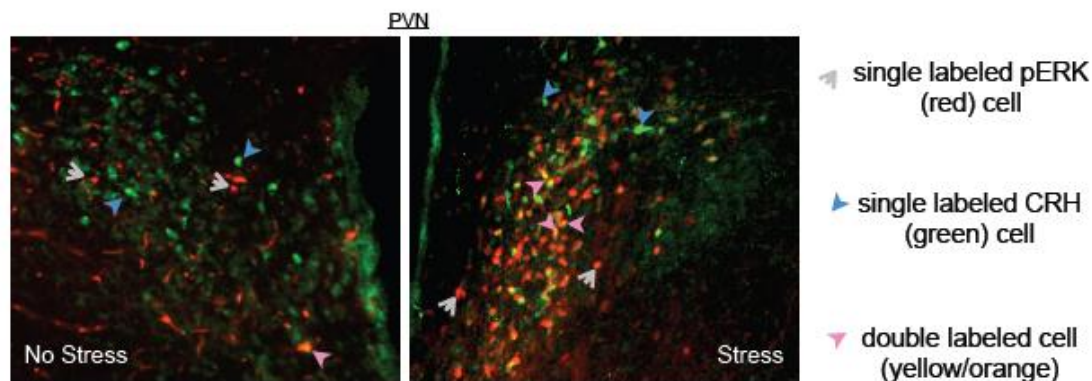

Figure 5: Restraint stress induces pERK within CRH neurons.

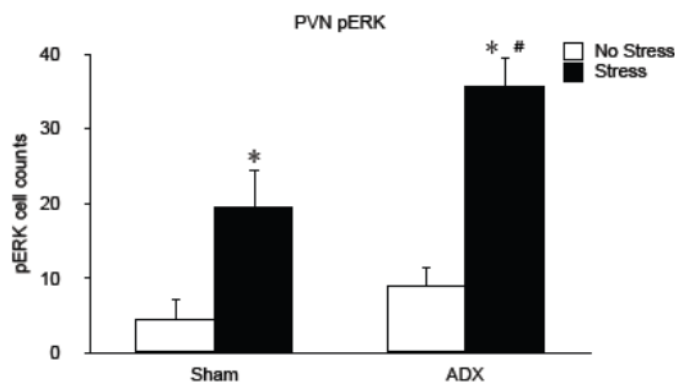

Figure 6: 15min RS induces pERK within the PVN. Adrenalectomy (ADX) augments stress-induced pERK. An asterisk indicates that group is significantly different from its pairwise no stress group while a pound sign indicates that a group is significantly different from its pairwise ADX group.

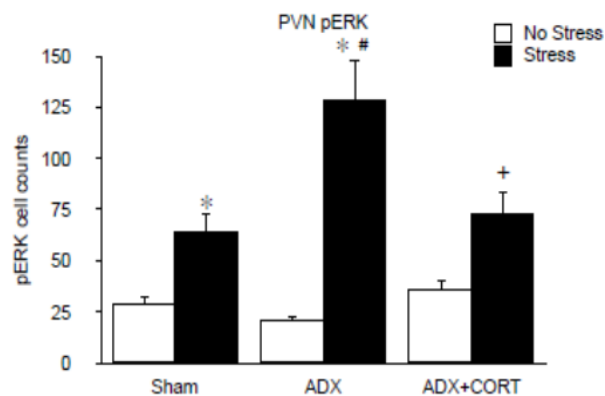

Figure 7: CORT replacement normalizes pERK back to sham levels within the PVN. An asterisk indicates that group is significantly different from its pairwise no stress group while a pound sign indicates that a group is significantly different from its pairwise ADX group. A plus sign indicates that the stress ADX and CORT replacement group is significantly different from its pairwise no stress group.

### *MKP-1 regulates ERK-1/2 activity*

Mitogen-activated kinase phosphatase 1 (MKP-1) is part of a larger family of phosphatases that dephosphorylate MAP kinases. In particular, MKP-1 regulates ERK-1/2 activity. Once a mitogen-activated protein kinase kinase (e.g. MEK) adds a phosphate group to a tyrosine and threonine residue on ERK (pERK), MKP-1 can bind to pERK. MKP-1 contains a MAP kinase docking site at its amino terminus that has a cluster of positively charged amino acids which interact with negatively charged amino acids on pERK. Binding of pERK then causes a conformational change in MKP-1 that allows it to remove the phosphate groups on pERK, thereby rendering it inactive. The two proteins then lose affinity for each other and separate (31).

Since pERK activity contributes to membrane excitability and neurohormone gene induction, MKP-1 could be an important target of glucocorticoid negative feedback actions. Moreover, glucocorticoids were shown to inhibit pERK by upregulating *mkp-1* expression and decreasing MKP-1 degradation in fibroblast cells (17). Likewise, glucocorticoids were also

shown to induce MKP-1 gene expression and dephosphorylate pERK in osteoblast cells (6). Although MKP-1 activity and expression has not been previously characterized within CRH neurons, the previous results in other cell types suggests that CORT could upregulate MKP-1 gene expression and thereby reduce the levels and/or duration of ERK activation. Therefore, MKP-1 upregulation could limit ERKs ability to contribute to CRH release and production of new neurohormone peptide.

### *Preliminary Studies*

I have assisted with several preliminary studies in the Spencer Lab exploring the feasibility of studying MKP-1 mRNA expression in rat brain. Outlined below are the key findings of those preliminary studies that set the stage for this Honors Thesis project.

#### Preliminary Experiment 1

Since glucocorticoids were shown to induce MKP-1 gene expression in other cell types such as osteoblast cells, we believed that glucocorticoids may also induce MKP-1 gene expression within neurons. As a result, we examined whether phasic CORT could affect MKP-1 gene transcription. Also, we wanted to characterize MKP-1 gene transcription within the prefrontal cortex (PFC) in response to CORT pretreatment because the PFC had been shown to indirectly modulate HPA axis activity.

Rats received either a CORT or vehicle pretreatment 1 or 3 hours prior to decapitation. We found that there was very little constitutive expression of the MKP-1 gene within the PVN and that phasic CORT had no effect on MKP-1 gene expression (Figure 8). However, we did find constitutive MKP-1 gene expression within the prelimbic and cingulate regions of the PFC. Interestingly, rats that received a 1 hour pretreatment, regardless of whether the pretreatment was the vehicle or CORT solution, showed markedly higher amounts of MKP-1 mRNA in the

prefrontal cortex. This suggested that the stress associated with the handling of these rats increased MKP-1 gene expression and that by 3 hours MKP-1 gene expression was returning to basal levels.

### Preliminary Experiment 2

We then examined the effect of restraint stress on MKP-1 gene expression. Given that restraint increased pERK activity within CRH neurons, we believed that MKP-1 gene expression also had the potential to be altered by stress because other studies have found increased MKP-1 gene induction as a result of increased MAPK pathway activity (16). MKP-1 gene induction could be an effective mechanism to limit the extent to which a cell is exposed to the effects of continued activation of MAP kinases (ERK).

We gave rats no stress (NS), 15 min, or 30 min restraint stress (RS) and measured MKP-1 gene expression within the PVN. We found that restraint induced MKP-1 mRNA compared to the NS group, with the highest amount of MKP-1 mRNA in rats that received 30 min restraint (Figure 9).

The result of this second preliminary experiment indicated that intracellular signaling pathways activated by stress-induced input to parvocellular neurons caused induction of MKP-1 gene transcription. Since MKP-1 inhibits pERK activity and pERK contributes to CRH peptide release and synthesis, we believed that our finding provided support for the idea that MKP-1 could be a target for glucocorticoid negative feedback actions. As a result, we decided to further examine MKP-1 gene expression in response to restraint stress in this Honors Thesis project. Moreover, although in the first preliminary experiment we found that phasic CORT did not affect basal MKP-1 gene expression within the PVN or PFC, we did not want to rule out the possibility that CORT could influence MKP-1 gene transcription. One possibility is that CORT

is not able to induce MKP-1 gene expression in the brain, but that CORT modulates stress-induced gene expression. Another consideration is that as previously mentioned, the extent to which phasic and tonic CORT causes negative feedback effects through different mechanisms has not been characterized. Thus, although phasic CORT did not affect MKP-1 gene transcription, tonic CORT could alter its expression. As a result, in this Honors Thesis project, we decided to look at the effects of tonic CORT on basal and stress-induced MKP-1 gene expression by removing endogenous glucocorticoids through adrenalectomy.

We believed that the results of this Honors Thesis project would be consistent with the results from the second preliminary experiment in that restraint stress would induce MKP-1 gene expression. Based on the results found in peripheral cell types, we believed that glucocorticoids would induce MKP-1 gene expression. The upregulation of the MKP-1 gene, we believed, would then limit pERK activity, which would decrease CRH peptide release and CRH gene transcription and thus contribute to glucocorticoid negative feedback effects.

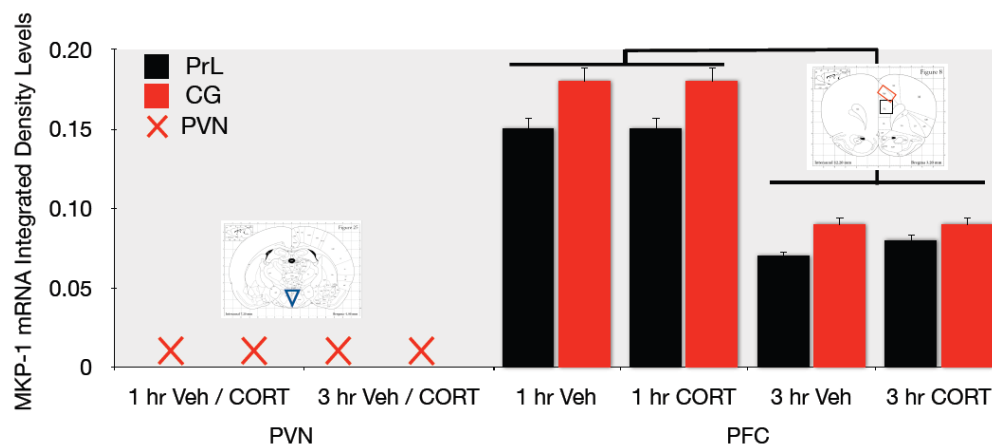

**Figure 8: Phasic CORT pretreatment has no effect on MKP-1 gene expression within the PVN or PFC (prelimbic and cingulate cortex). Note the substantially larger MKP-1 mRNA amounts within the PFC of rats that received a 1 hour vehicle or CORT pretreatment compared to the 3 hour pretreatment.**

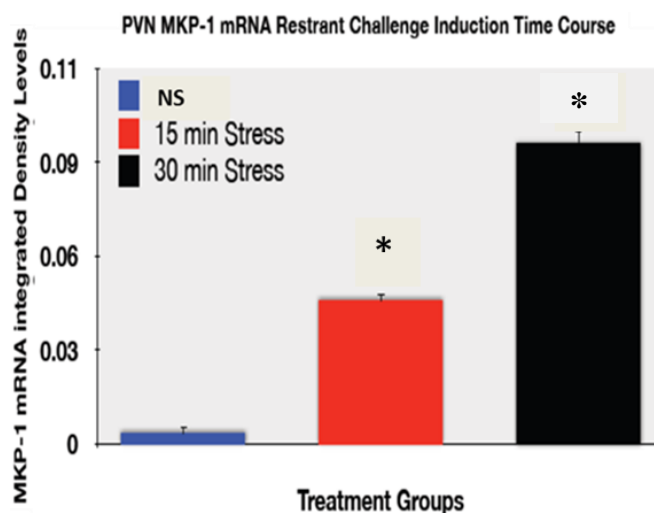

Figure 9: Restraint stress induces MKP-1 mRNA within the PVN, with the highest levels at 30min RS. The asterisk indicates groups that are significantly different from the no stress (NS) group.

## II. Methods

### *Animals*

Young adult male Sprague-Dawley rats (Harlan Laboratories, Indianapolis, IA) weighing between 280 and 305 g at time of experimentation were housed two per-cage. The colony room lights were regulated on a 12 hour light/dark cycle and rats were given rat chow (Purina Rat Chow, Ralston Purina, St. Louis, MO, USA) and tap water ad libitum. Rats were allowed at least a 2 week acclimation to the colony room before any initiation of experimental procedures. The experiment was performed during the first half of the rats' inactive period, when basal CORT secretion is at its circadian trough. Handling and testing of all rats conformed to ethical procedures approved by the University of Colorado Institutional Animal Care and Use Committee.

### *Surgery*

Rats were adrenalectomized bilaterally (ADX) or were sham-ADX. After being anesthetized with halothane, rats received bilateral incisions made through the skin and peritoneal wall next to each kidney. Sham-ADX rats experienced the same procedure as ADX

rats, but adrenal glands were not removed. Moreover, all ADX and sham-ADX rats were given 3 days to recover from surgery before the experimental test day. ADX rats were given 0.9% saline drinking water ad libitum.

### *Experimental Design*

On experiment day, ADX and Sham-ADX rats received either no stress or 30min restraint stress before decapitation (2x2 between subjects factorial design; n=6; N=24). Plexiglas restraint tubes that measured 17.5 cm in length and 7.0 cm in diameter were used. The front end of the tube was blocked by a Plexiglas plunger containing several air holes. Immediately after decapitation, brains were removed and placed in isopentane (between -30 and -40 C) to flash freeze, after which brains were placed in a -80 C freezer for later analysis. Blood samples were centrifuged, and plasma was removed and stored at -80 C until later analysis. Directly after decapitation, trunk blood was collected into EDTA coated tubes (vacutainer, Becton-Dickinson). All samples were centrifuged for 15 min at 4 C to separate plasma from the red blood cells, plasma samples were then aliquoted into microfuge tubes and snap frozen on dry ice.

### *ACTH radioimmunoassay*

ACTH (pg/ml) was determined in duplicate (100  $\mu$ l plasma) by competitive radioimmunoassay protocol as described previously (21, 22). Radio-labeled 125I ACTH-Tracer was obtained from DiaSorin (Cat # 20515) and primary ACTH anti-serum Rb 7 diluted to a final concentration of 1:30,000 was provided courtesy of Dr. William Engeland, University of Minnesota.

### *In Situ Hybridization (ISH)*

Brains were later sectioned in coronal slices at 12  $\mu$ m thick (-20 C) on a cyrostat. Brain sections were thaw-mounted on Superfrost Plus slides. Slides were placed back in -80 C freezer



for later use on ISH assays. Sections used in ISH analysis were fixed in a buffered 4% paraformaldehyde solution for 30min at room temperature. Slides were washed in 2x saline sodium citrate (SSC) and acetylated in 0.1 M triethanolamine containing 0.25% acetic anhydride for 10 min to minimize nonspecific hybridization by reducing positive charge on tissue and Superfrost Plus slides. Slides were then washed again in SSC and then in distilled water, dehydrated in a series of graded ethyl alcohol concentrations, and air-dried.

35S-UTP labeled cRNA probes were generated for MKP-1 mRNA from cDNA subclones in transcription vectors using standard in vitro transcription methodology. Riboprobes were diluted in hybridization buffer to a concentration of approximately 1 million counts per slide (65  $\mu$ l/slide). Diluted probe was applied, and a coverslip was placed on each slide. Slides were placed in sealed plastic boxes lined with chromatography paper moistened with 50% formamide in MQH<sub>2</sub>O and were incubated overnight at 55 C.

The next day, coverslips were floated off, and slides were rinsed several times in 2xSSC. The slides were then incubated in RNase at 37 C for 1 hour to remove unhybridized RNA fragments. Slides were then washed successively in decreasing concentrations of SSC, incubated in a stringent wash of 0.1x SSC at 60 C for 1 hour to denature weakly bound hybrids, and then dehydrated in graded concentration of EtOH. Once the slides were dry, they were exposed to Kodak XAR X-ray film (Kodak, Rochester, NY, USA). Slides assayed for MKP-1 mRNA in the PVN had an exposure time of 17 days whereas pituitary sections were exposed to film for 14 days.

Films were developed using a Kodak film developer. The amount of probe hybridized in each brain region were measured as regional optical densities of auto-radiographic film images

with a computerized image analysis system composed of a light box, a solid state video camera, and PC based NIH-image analysis software.

Uncalibrated optical densities for each region of interest, which included the PVN, anterior pituitary, prelimbic cortex, and infralimbic cortex, were measured using the program ImageJ. For the PVN, measurements for four sections were taken for both hemispheres of the brain for all rats (8 measurements for each rat brain). Measurements were also taken for four sections of the anterior pituitary. On the other hand, both hemispheres of six sections were measured for the prelimbic and infralimbic cortex. Graphs showing relative differences between groups were created by measuring the average optical density for each rat and then averaging the optical densities of each rat to give an overall mean value for that treatment effect.

#### *Statistical Analysis*

For measurement of ACTH secretion, all absolute values for ACTH were normalized to be expressed as a proportion response to the no-stress SHAM group and then underwent log transformation for statistical purposes. A two-way factorial analysis of variance (ANOVA) was calculated in Statistical Package for the Social Sciences (SPSS) for each dependent measure. Significant F-test results were then followed with post hoc tests using Fishers Least Significant Difference Test (FLSD) in order to assess significant differences between pairs of groups. An alpha-level of  $P \leq 0.05$  was used to determine statistical significance. For the graphs, an asterisk symbol over a particular group indicates that that group is significantly different from its pair wise no stress group. On the other hand, groups that are significantly different from their pair wise sham group are marked with a pound sign.

### III. Results

Rats challenged with 15 min of restraint increased ACTH secretion as supported by a main effect of stress  $F(1,19)=78.3$ ,  $p<0.05$  (Figure 10). The absence of glucocorticoid activity (via ADX) also increased ACTH secretion in both the no stress and restraint stress groups, as supported by a main effect of ADX  $F(1,19)=33.8$ ,  $p<0.05$ .

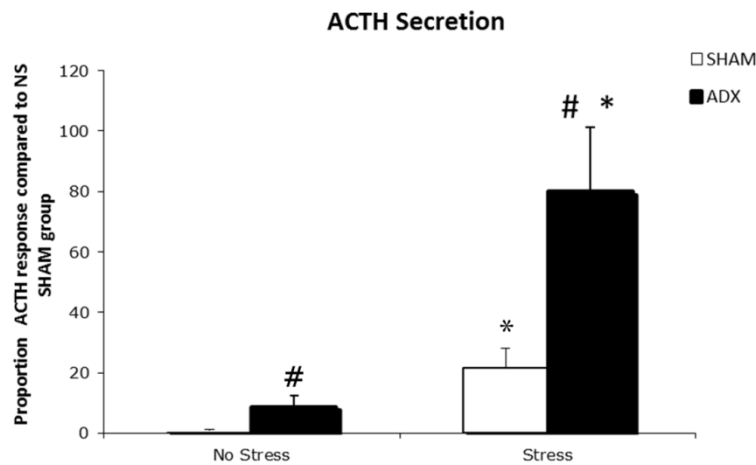

**Figure 10: RS and ADX increase ACTH secretion. ADX augments stress-induced ACTH secretion.**

Rats exposed to restraint (30min) had an increase in MKP-1 gene expression in the PVN compared to the no stress groups  $F(1,19)=37.4$ ,  $p<0.05$  (Figure 11). Interestingly, ADX increased MKP-1 gene expression within the restraint stress group as supported by a main effect of ADX  $F(1,19)=11.0$ ,  $p<0.05$ . There was a trend for adrenalectomy to have exacerbated MKP-1 gene expression within the restraint stress group, but this interaction between stress and adrenalectomy was not significant  $F(1,19)=2.21$ ,  $p=0.154$ .

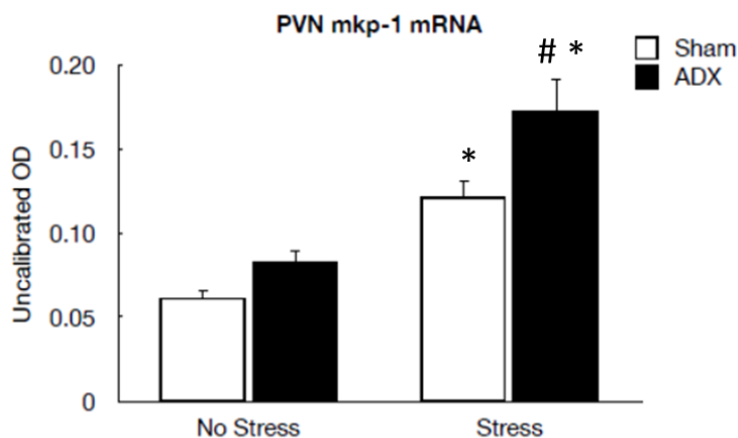

Figure 11: RS induces MKP-1 expression within the PVN compared to the NS group. ADX also increases MKP-1 expression compared to the Sham group.

For the anterior pituitary, there is a main effect of stress whereby restraint stress increased MKP-1 mRNA compared to the no stress groups  $F(1,19)=29.8$ ,  $p<0.05$  (Figure 12). Non-stressed Sham and ADX rats had the same amount of MKP-1 mRNA within the pituitary gland FLSD,  $p=0.89$ . However, loss of glucocorticoid activity via ADX augments MKP-1 gene expression of rats that were challenged with restraint  $F(1,19)=5.07$ ,  $p<0.05$  and consequently there is an interaction between restraint stress and ADX  $F(1,19)=5.1$ ,  $p<0.05$ .

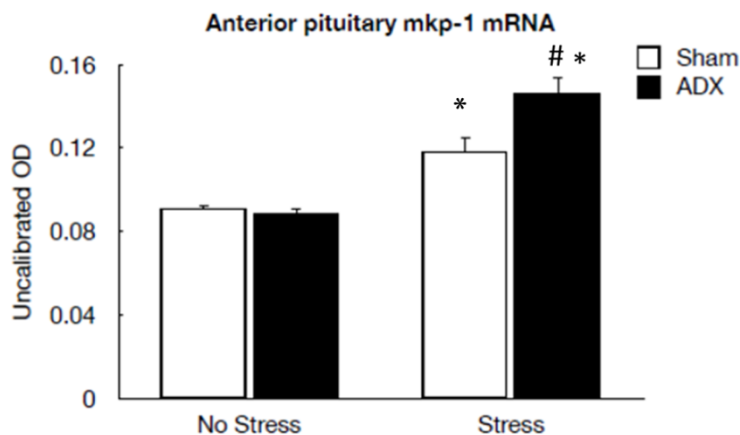

Figure 12: RS induces MKP-1 mRNA within the pituitary. There is no effect of ADX within the NS group, however ADX augments stress-induced MKP-1 gene expression.

Restraint stress increased MKP-1 mRNA in both Sham and ADX rats compared to the no stress groups within the prelimbic cortex  $F(1,19)=14.7$ ,  $p<0.05$  (Figure 13). We found a trend for ADX to increase MKP-1 expression in both the no stress and restraint stress groups  $F_{(1,19)}=3.12$ ,  $p=0.09$ .

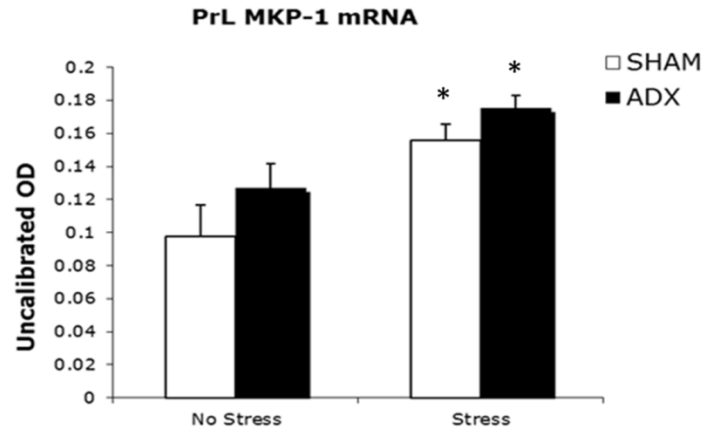

Figure 13: RS induces MKP-1 mRNA within the prelimbic cortex, but there is no effect of ADX.

Restraint induced MKP-1 gene expression in the infralimbic cortex  $F_{(1,19)}=42.8$ ,  $p<0.05$  (Figure 14). However, the loss of tonic glucocorticoid activity increased MKP-1 gene expression within both the no stress and restraint stress groups  $F(1,19)=7.9$ ,  $p<0.05$ .

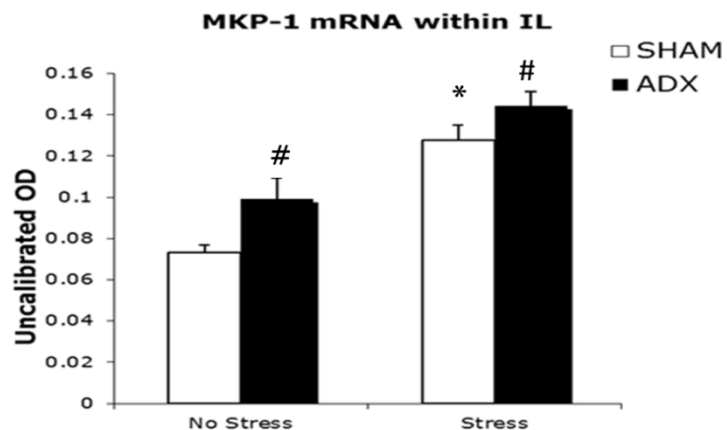

Figure 14: Within the infralimbic cortex, RS and ADX induce MKP-1 gene expression.

#### IV. Discussion

In this study we found that restraint stress induced HPA axis activity and ADX exacerbated stress-induced HPA axis activity as measured by ACTH hormone secretion. These results confirm previous findings (8, 22). Within all brain regions we examined and the anterior pituitary, restraint stress induced MKP-1 gene expression. Moreover, ADX augmented MKP-1 gene expression in all regions except the prelimbic cortex. Interestingly, there was a significant interaction between stress and ADX within the pituitary. These findings suggest that restraint stress caused the activation of intracellular signaling transduction pathways that led to induction of MKP-1 gene expression and that tonic glucocorticoids suppressed stress-induced MKP-1 gene expression within the PVN and anterior pituitary.

The amount of ACTH secretion is indicative of HPA axis activity because activation of the HPA axis causes release of ACTH. Rats that received restraint stress showed elevated concentrations of ACTH within their circulation because the stress challenge caused HPA axis activation. Moreover, removal of the presence of glucocorticoids via ADX prevents tonic and phasic glucocorticoid negative feedback from happening, thus the HPA axis has increased continuous activation. When ADX was combined with restraint stress, ACTH secretion was exacerbated because the stress challenge caused activation of an already stimulated HPA axis.

We found that restraint stress induced MKP-1 expression within the PVN, pituitary, prelimbic cortex, and infralimbic cortex. Similarly, MKP-1 gene expression was induced within the prefrontal cortex upon receiving acute or chronic electroconvulsive seizures (15). Although we use restraint stress for our experimental design, the shock used to induce electroconvulsive seizures is a physical stressor. Therefore, it appears that stress causes the activation of intracellular signaling transduction pathways within prefrontal cortex neurons that lead to the

induction of MKP-1 gene expression. However, we are the first to examine MKP-1 gene expression in response to restraint stress within the PVN or pituitary.

Removal of endogenous glucocorticoids via ADX also induces MKP-1 gene expression within the PVN, pituitary, and the infralimbic cortex. MKP-1 mRNA within the prelimbic cortex was unaffected by ADX, however the prelimbic cortex has different cell populations than the other brain regions and pituitary. Therefore, prelimbic cortex neurons could respond differently to tonic glucocorticoids. Yet, we did find a strong trend for ADX to increase MKP-1 gene expression within the prelimbic cortex, so perhaps if we increased our sample size we would find a significant difference between ADX and Sham groups. Moreover, the magnitude of the effect of ADX on MKP-1 gene transcription is much larger within the PVN, which suggests that the PVN is more responsive to glucocorticoid negative feedback compared to the prelimbic and infralimbic cortex. The PVN has more GR than the frontal cortex (23), so this could explain why restraint stress has a larger effect within the PVN. Within cells where MKP-1 gene transcription was affected by ADX, tonic glucocorticoids could affect the transcription of genes besides MKP-1 whose protein products then affect MKP-1 expression. However, it has recently been found that the MKP-1 gene has a glucocorticoid response element (GRE) (28). Although the previous study showed that glucocorticoids induced MKP-1 expression, it is possible that within neurons there are proteins that are not present within peripheral tissues at the GRE that interact with the GR to repress transcription of the MKP-1 gene.

ADX augments stress-induced MKP-1 gene expression within the pituitary. Corticotrophs that release ACTH differ from neurons in their function and pattern of gene expression. As a result, intracellular signaling pathways that are activated by stress have different outcomes within corticotrophs compared to the neuronal cell types we looked at. One outcome of

activation of intracellular signaling pathways within the pituitary appears to be the modulation of proteins that are targets of glucocorticoid actions as seen by the interaction between restraint stress and ADX.

Initially, we did not expect that tonic glucocorticoids would constrain MKP-1 gene transcription. Several studies within peripheral tissues indicated that glucocorticoids mediated anti-inflammatory effects by inhibiting ERK-1/2 via increased MKP-1 gene expression (5, 14), as well as decreased MKP-1 degradation (5). As a result, we believed that MKP-1 gene transcription would be upregulated by tonic CORT in order to prevent the responsiveness of signaling pathways to activation by stress-induced input. Yet, tonic CORT may indirectly repress MKP-1 gene expression by decreasing pERK activity. Our lab has shown that tonic CORT decreases pERK levels within the PVN, so it is possible that the decreased pERK activity could lead to less MKP-1 gene expression since MAPK pathway activity can regulate phosphatase gene expression (16). However, MKP-1 gene upregulation could help compensate for the inability to achieve glucocorticoid negative feedback in ADX rats because increased MKP-1 gene expression probably leads to decreased pERK activity. This decreased pERK activity would result in decreased CRH peptide release and CRH gene transcription. Moreover, other research from our lab shows that ADX also induces numerous genes besides MKP-1 within the PVN and other various brain regions (8, 22). Therefore, it appears that tonic CORT constrains the overall activity of neurons and corticotrophs. When this constraint is taken away by ADX, gene expression of MKP-1, as well as other genes, is upregulated. Furthermore, tonic CORT could achieve this constraint by either altering the neural drive to PVN or acting directly within CRH neurons and corticotrophs. Also, our finding that tonic CORT, but not phasic CORT, represses



MKP-1 gene expression suggests that tonic and phasic CORT can use different mechanisms to affect gene transcription.

In the future, we need to confirm that tonic glucocorticoids, rather than other hormones secreted by the adrenal gland, suppress MKP-1 gene transcription. The increase in MKP-1 gene expression seen with ADX could be the result of other hormones secreted from the adrenal glands, or even the result of phasic CORT because removing the adrenal glands also takes away phasic CORT secretion. As a result, we should perform the same experiment, except add an additional treatment group that receives CORT in their drinking water to simulate a tonic CORT secretion pattern. If CORT replacement normalizes MKP-1 gene expression to Sham levels, then we can be certain that tonic CORT suppresses MKP-1 gene expression. Moreover, we should determine whether MKP-1 protein levels also change with restraint stress and ADX by repeating the same experiment and using immunohistochemistry or Western blot to examine MKP-1 protein levels. It is possible that the amount of MKP-1 protein may not increase upon exposure to restraint stress or ADX because of mRNA degradation, so we need to rule this out. We should also try to determine whether tonic glucocorticoids suppress MKP-1 gene expression directly within the HPA axis or indirectly. To do this, we could surgically place a cannula above the PVN and give a microfusion of CORT to ADX rats that simulates a tonic glucocorticoid secretion pattern. If we obtain the same results whereby ADX increases MKP-1 gene expression and CORT normalizes MKP-1 mRNA to sham levels, then tonic glucocorticoids act directly within the PVN to suppress MKP-1 gene expression. Also, we could see if phasic CORT, when combined with restraint stress, alters MKP-1 gene expression. Since stress-induced input to the PVN and pituitary leads to the activation of signaling pathways that then alter gene transcription, it is possible that certain protein products of these genes may need to be present (or absent) in

order for phasic glucocorticoids to affect MKP-1 gene transcription. More importantly, we need to determine whether pERK or tonic CORT is modulating MKP-1 gene expression by surgically placing a cannula above the PVN and microinfusing a MAPK pathway inhibitor. If we obtain the same results, then tonic CORT, rather than pERK, suppresses MKP-1 gene expression.

## References

1. Barden, N., Implication of the hypothalamic-pituitary-adrenal axis in the physiopathology of depression, *J Psychiatry Neurosci*, 29 (2004) 185-93.
2. Baumann, C.T., Lim, C.S. and Hager, G.L., Intracellular localization and trafficking of steroid receptors, *Cell Biochem Biophys*, 31 (1999) 119-27.
3. Chrousos, G. and Gold, P., The concepts of stress and stress system disorders, *J Amer Med Assoc*, 267 (1992) 1244-1252.
4. Dallman, M., Akana, S., Cascio, C., Darlington, D., Jacobson, L. and Levin, N., Regulation of ACTH secretion: variations on a theme of B, *Recent Prog Horm Res*, 43 (1987) 113-173.
5. Englebrecth Y., Wet de. H., Horshach K., Langeveldt, R., Hough F.S., and Hulley P.A., Glucocorticoids induce rapid up-regulation of mitogen-activated protein kinase phosphatase-1 and desphosphorylation of extracellular signal-regulated kinase and impair proliferation in human and mouse osteoblast cell lines, *Endocrinology*, 144 (2003) 412-422.
6. Evans, R., The steroid and thyroid hormone receptor superfamily, *Science*, 240 (1988) 889-895.
7. Flak JN, Ostrander MM, Tasker JG, and Herman JP. Chronic stress-induced neurotransmitter plasticity in the PVN, *J Comp Neurol*, 517 (2009) 156-65.
8. Girotti, M, Weinberg, MS and RL Spencer. Differential responses of HPA axis immediate early genes to corticosterone and circadian drive, *Endocrinology*, 148 (2007) 2542-52.
9. Herman JP, Flak J, Jankord R. Chronic stress plasticity in the hypothalamic paraventricular nucleus, *Prog Brain Res*, 2008; 170:353-64.
10. Impey S, Obrietan K, Wong ST, Poser S, Yano S, Wayman G, Deloulme JC, Chan G, Storm DR. Cross talk between ERK and PKA is required for Ca<sup>2+</sup> stimulation of CREB dependent transcription and ERK nuclear translocation, *Neuron*, 21 (1998) 869-83.
11. Johnson, E.O., Kamilaris, T.C., Chrousos, G.P. and Gold, P.W., Mechanisms of stress: a dynamic overview of hormonal and behavioral homeostasis, *Neurosci Biobehav Rev*, 16 (1992) 115-30.
12. Jones MW, Errington ML, French PJ, Fine A, Bliss TV, Garel S, Charnay P, Bozon B, Laroche S, Davis S, A requirement for the immediate early gene Zif268 in the expression of late LTP and long-term memories, *Nat Neurosci*, 4 (2001) 289-296
13. Kalia, M., Assessing the economic impact of stress--the modern day hidden epidemic, *Metabolism*, 51(2002) 49-53.
14. Kassel, O., Sancono, A., Kratzschmar, J., Kreft, B., Stassen, M., and Cato, A., Glucocorticoids inhibit MAP kinase via increased expression and decreased degradation of MKP-1, *The EMBO Journal*, 20 (2001) 7108-7116.
15. Kodama, M., Russell, D.S., Duman, R.S., Electroconvulsive seizures increase the expression of MAP kinase phosphatases in limbic regions of rat brain, *Neuropsychopharmacology*, 30 (2005) 360-371.

16. Li, J., Gorospe, M., Hutter, D., Barnes, J., Keyse, S.M., and Lui, Y., Transcriptional induction of MKP-1 in response to stress is associated with histone H3 phosphorylation-acetylation, *Mol Cell Biol*, 21 (2001) 8213-8224.
17. Makara, G.B. and Haller, J., Non-genomic effects of glucocorticoids in the neural system. Evidence, mechanisms and implications, *Prog Neurobiol*, 65 (2001) 367-90.
18. McKay, L. and Cidlowski, J., Molecular control of immune/inflammatory responses: interactions between nuclear factor-kB and steroid receptor-signaling pathways, *Endocrine Reviews*, 20 (1999) 435-459.
19. Miller, D.B. and O'Callaghan, J.P., Neuroendocrine aspects of the response to stress, *Metabolism*, 51 (2002) 5-10.
20. Munck, A., Guyre, P.M. and Holbrook, N.J., Physiological functions of glucocorticoids in stress and their relation to pharmacological actions, *Endocrine Reviews*, 5 (1984) 25-44.
21. Nicholson W, Davis D, Sherrell B, Rapid radioimmunoassay for corticotropin in unextracted human plasma, *Clinical Chemistry*, 1984.
22. Pace TWW, Gaylord RI, Jarvis E, Girotti M, Spencer RL., Differential glucocorticoid effects on stress-induced gene expression in the paraventricular nucleus of the hypothalamus and ACTH secretion in the rat, *Stress*, 12 (2009) 400-11.
23. Parker, K.J., Schatzberg, A.F. and Lyons, D.M., Neuroendocrine aspects of hypercortisolism in major depression, *Horm Behav*, 43 (2003) 60-6.
24. Reul, J. and de Kloet, E., Two receptor systems for corticosterone in rat brain: microdistribution and differential occupation., *Endocrinology*, 117 (1985) 2505-2511.
25. Reul, J.M.H.M., van den Bosch, F.R. and de Kloet, E.R., Differential response of type I and type II corticosteroid receptors to changes in plasma steroid level and circadian rhythmicity, *Neuroendo*, 45 (1987).
26. Sapolsky, R.M., Romero, L.M. and Munck, A.U., How do glucocorticoid influence stress responses? Integrating permissive, suppressive, stimulatory, and preparative actions, *Endocrine Reviews*, 21 (2000) 55-89.
27. Sherwood, Lauralee. *Human Physiology*. Canada: Brooks/Cole, 2010.
28. Ship, L.E., Lee, J.V., Yu, C., Pufall, M., Zhang, P., Scott, D., and Wang, J., Transcriptional Regulation of Human Dual Specificity Protein Phosphatase 1 (DUSP1) Gene by Glucocorticoids, *Plos One*, 5(2010) 1-11.
29. Spencer, R.L., Miller, A.H., Moday, H., Stein, M. and McEwen, B.S., Diurnal differences in basal and acute stress levels of type I and type II adrenal steroid receptor activation in neural and immune tissues, *Endocrinology*, 133 (1993) 1941-50.
30. Steckler, T., Holsboer, F., and Reul, J.M.H.M, Glucocorticoids and depression, *Baillière's Clinical Endocrinology and Metabolism*, 13 (1999) 597-614.
31. Theodosiou, A., and Ashworth, A., Protein family review: MAP kinase phosphatases, *Genome Biology*, 3 (2002): 3009.1-3009.10.

32. VanItallie, T.B., Stress: a risk factor for serious illness, *Metabolism*, 51, suppl 1 (2002) 40-45.
33. Watts A.G., Glucocorticoid regulation of peptide genes in neuroendocrine CRH neurons: a complexity beyond negative feedback, *Front Neuroendocrinol*, 26 (2005)109-130
34. Weinberg, M.S., Johnson, D.C., Bhatt, A.P., and Spencer, R.L., Medial prefrontal cortex activity can disrupt the expression of stress response habituation, *Neuroscience* (2010), doi: 10.1016/j.neuroscience.2010.04.006
35. Wölfl S, Martinez C, and Majzoub JA. Inducible binding of cyclic adenosine 3',5'-monophosphate (cAMP)-responsive element binding protein (CREB) to a cAMP responsive promoter in vivo, *Mol Endocrinol*, 13 (2009) 659-69.
36. Yang, J., Liu, J. and DeFranco, D.B., Subnuclear trafficking of glucocorticoid receptors in vitro: chromatin recycling and nuclear export, *J Cell Biol*, 137 (1997) 523-38.
37. Yehuda, R., Golier, J.A., Halligan, S.L., Meaney, M. and Bierer, L.M., The ACTH response to dexamethasone in PTSD, *Am J Psychiatry*, 161 (2004) 1397-403.